

ADDENDUM NO. 1
TO PLANS, SPECIFICATIONS AND CONTRACT DOCUMENTS

TO: ALL PLANHOLDERS AND PROSPECTIVE BIDDERS

FOR: LINCOLN REGIONAL CENTER TUNNEL REPAIR PHASE 2
LRA JOB NO. 0113069.01-255

OWNER: STATE OF NEBRASKA, DAS/STATE BUILDING DIVISION

ENGINEER: LAMP, RYNEARSON & ASSOCIATES, INC.
14710 WEST DODGE ROAD, SUITE 100
OMAHA, NEBRASKA 68154-2027

DATE: JANUARY 31, 2017

The following changes, corrections, clarifications, and additions shall be made to the Specifications and Contract Documents for the above-named project and shall be as binding as if incorporated in the original Contract Documents. The Contractor shall acquaint himself with all aspects of this Addendum.

All other provisions and stipulations of the Contract Documents remain in effect as originally issued.

The Contractor shall acknowledge receipt of all addenda on the Proposal Form.

The following shall be modified, or added to as follows:

PLANS

1. Sheet 5 of 7: Detail 2/5 "SUMP PUMP DRAIN ELEVATION SCHEMATIC" & detail 3/5 "OUTLET LOCATION SCHEMATIC". Add a callout note to the detail where the 1½" pipe connects to the curb to "CONSTRUCT 12" X 15" CONCRETE PAD, 8" THICK AROUND DISCHARGE PIPE, BEHIND CURB" and show a sketch of the pad in the details. See Attachment No. 1.

CONTRACT DOCUMENTS

1. SUPPLEMENTARY CONDITIONS page 033713-2 of the Shotcrete Supplementary Conditions, delete paragraph 1.6 A.

ATTACHED ITEMS

1. Attachment No.1 shows changes made to details 2/5 & 3/5 on Sheet 5 of the Plans.
2. A copy of the Pre-Bid Meeting attendees sign-in sheet has been added as Appendix Item 1 and is attached to this Addendum as Attachment No. 2.

OTHER INFORMATION

1. Additional photographs of the repair locations are available for viewing. The photographs are available via downloading from an FTP site. Contact John Hill (John.Hill@LRA-inc.com) or Rob Vanderveen (Rob.Vanderveen@LRA-inc.com) to obtain the FTP site location and information on how to download the files. Phone: 402-496-2496.

ENCLOSURES
END OF ADDENDUM

Sincerely,

LAMP RYNEARSON



John M. Hill, P.E.
Senior Project Engineer

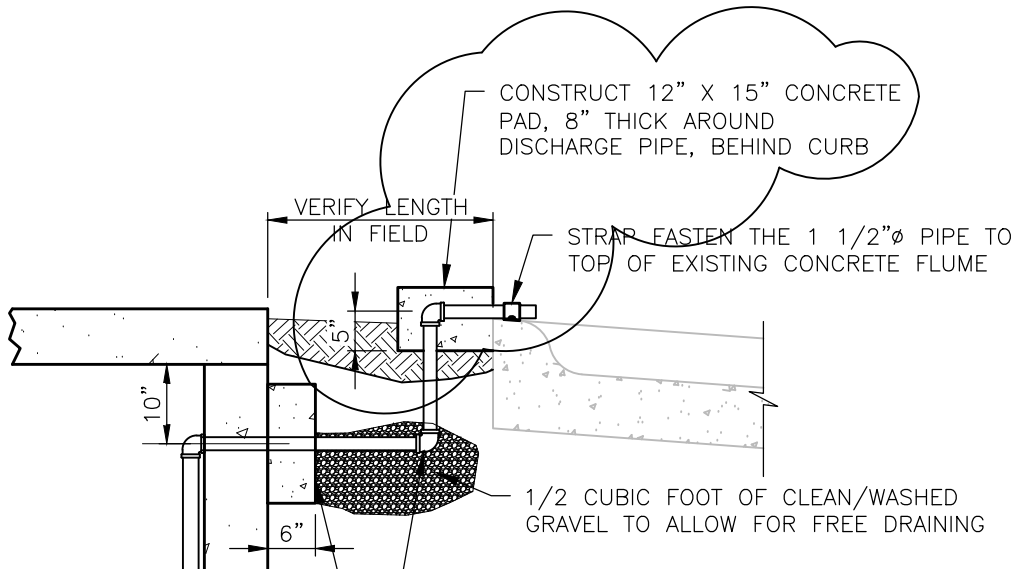

PARTIAL DETAIL
SUMP PUMP DRAIN ELEVATION SCHEMATIC

2
5

 Scale: 1/2" = 1'-0"

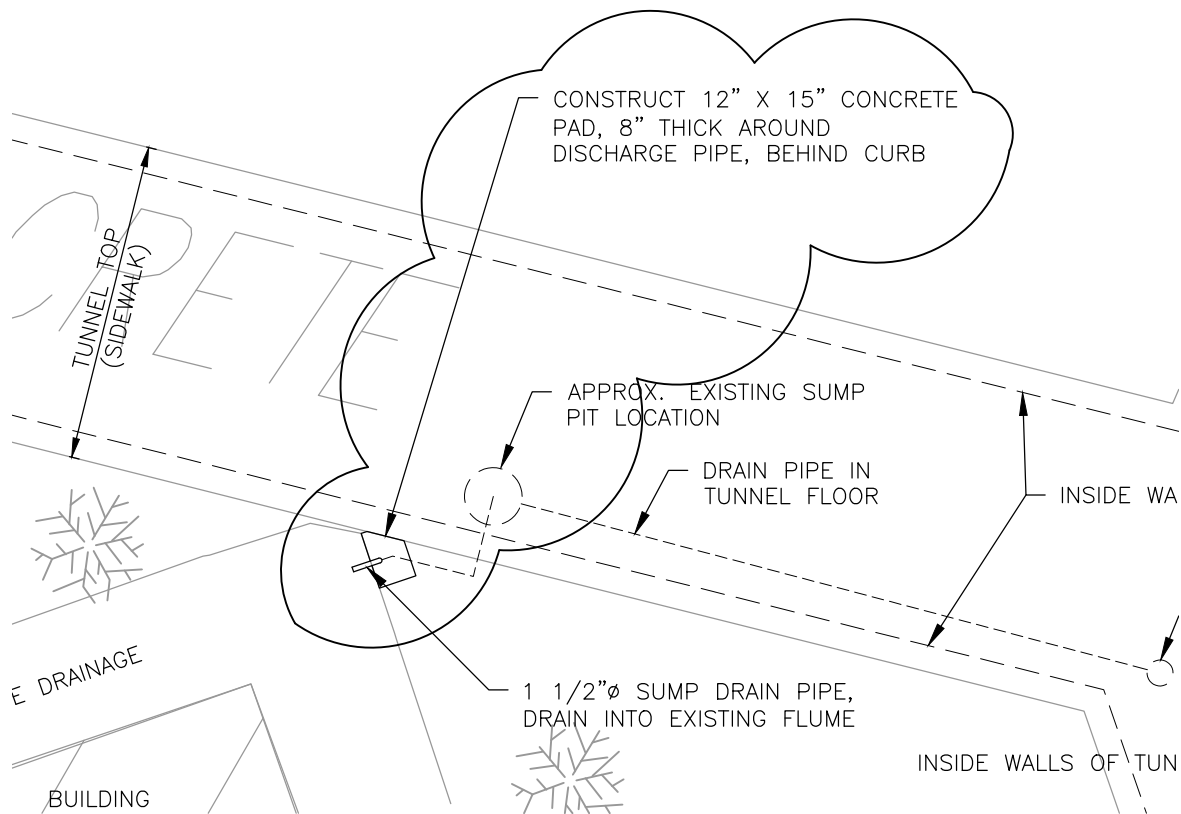

PARTIAL DETAIL
OUTLET LOCATION SCHEMATIC

3
5

 Scale: 1" = 5'-0"



LAMP RYNEARSON
 & ASSOCIATES

14710 West Dodge Road, Suite 100 402.496.2498 | P
 Omaha, Nebraska 68154-2027 402.496.2730 | F
 www.LRA-Inc.com

DRAWN BY
 JMH

DESIGNED BY
 JMH

REVIEWED BY
 RV

PROJECT - TASK NUMBER
 0113069.01-255

DATE
 01/31/2017

BOOK AND PAGE

REVISIONS

