



ADDENDUM NO. 1
NDOR / ADA FACILITY UPGRADES
REST AREAS – SEGMENT 1
HGM PROJECT NO. 180014
NDOR PROJECT NO. AFE W-002

HGM PROJECT # 180014

DATE OF ISSUE: Monday, October 06, 2014

DATE OF BID OPENING: Thursday, October 9, 2014 at 3:30 pm

NOTE TO PLANHOLDERS: Please insert this addendum into your copy of the Project Contract Documents. The following additions or changes to the Contract Documents for the above named project are issued by the Architect and have the same force and effect as though part of the original issued.

CHANGES TO PROJECT MANUAL

NDOR Project Number is AFE W-002, not AFE W-200 as shown in Project Manual.

BID PROPOSAL

Refer to Bid Proposal Form Page 6: 46701 – York EB RA Schedule of Values:

Delete in its entirety. Replace with attached 46701 – YORK EB RA REVISED Schedule of Values.

Changes include updates of Estimated Quantities to Items C-4, C-5, C-7, and C-9.

DIVISION 22 – PLUMBING

Drinking Fountain shall be Heavy duty vandal resistant elkay stainless steel drinking fountain:

EHW214C or approved equal.

Provide all associated accessories required for ADA installation including but not limited to plumbing, mounting brackets, stainless steel closure panels and cane detection skirts.

SECTION 32 13 13 CONCRETE PAVING

Refer To 32 13 13-2, lines 28 and 30; Delete the following:

“with 1P Cement”.

CHANGES TO DRAWINGS

SHEETS C1.1, C1.2, C1.3 of 46701 – York EB RA, attached.

Quantities and Locations of Sidewalk Removals and Replacements have been modified.

Quantities and Locations of Curb and Gutter Removal and Replacements have been modified.

Refer to 46701 – York EB RA Revised Schedule of Values for Quantity Changes.

1 If a substitute material, product or manufacturer has been requested to be allowed, it will appear in an
2 addendum only if approved. If not in the addenda, the alternate method, product or manufacturer is not
3 approved.
4

5 All other stipulations and requirements of the plans and specifications remain in effect. This addendum
6 shall be attached to and made part of the Contract Documents and shall be acknowledged with the
7 bidders proposal.
8

9
10 Respectfully Submitted:
11 HGM ASSOCIATES INC.
12
13



14
15
16 Dean Fajen, P.E., A.I.A.
17 Project Manager
18
19

20 Attachment: Pre-Bid Sign-in Sheet
21 Bid Proposal Page 46701 – YORK EB RA REVISED Schedule of Values
22 SHEETS C1.1, C1.2, C1.3 of 46701 – YORK EB RA
23



ASSOCIATES INC.

PROJECT: NDOR ADA Facility Upgrades HGM #180014

Meeting Place: Multiple and Various Locations

Date & Time: Friday, October 3, 2014 9:00 a.m.

NAME	AFFILIATION	MAILING ADDRESS	PHONE / FAX	CELL/E-MAIL
*** PLEASE PRINT ***	*** PLEASE PRINT ***	*** PLEASE PRINT ***		
Jon Dybbel	Erich Broer Const	2201 W. Cardwell Rd. Lincoln Ne 68523	402-438-2165 P: 402-438-2165 C: 402-450-9518	C: 402-450-9518 E: eb90138@windstream.net
Kenn Sasse	HGM	CB, IOWA		P: C: 402-209-2087 E: ksasse@hgmonline.com
Rob Lechner	HGM	"		P: 712 323-0530 E: C:
PAUL VESTER	VECO CONSTRUCTION	5180 SE 70th RD ST. JOSEPH, MO 64507	816 232 9044 P: 816 232 3134	C: 816 387 1884
Rick Hart	Rogge G.C.	6101 S. 58th Suite A Lincoln Ne 68516	402-441-3100 P: 402-441-3100 E: rhart@roggeinc.com	C: 402-470-1989
CHARLES TIMMER	TIM'S PRH	POB 517 NONFOLK	402-760-0953 P: 402-565-4844 E: 402-565-4844	C:
Dean Fjyn	HGM			P: C E: C
				P: C E: C

46701 - YORK EB RA REVISED Schedule of Values

Item No.	Description	Lump Sum Amount	
1	BUILDING ADA IMPROVEMENTS (Reference "A Series" Sheets)	\$	
2	SITE ADA IMPROVEMENTS (Reference "C Series" Sheets)	\$	
TOTAL Bid Without Alternates (Amount In Figures):		\$	
TOTAL Bid Without Alternates (Amount Written in Words)			
PROVIDE UNIT PRICES IN EVENT OF OVERAGE			
		ESTIMATED QUANTITY	UNIT
			UNIT PRICE \$
1	Mobilization (Not to exceed 10% of Total Amount Bid)	1.00	LS
2	Site Restoration (Seeding, Mulching, and Fertilizing)	1.00	LS
3	Trim Shrubbery	150.00	SF
4	Remove Walk	910.00	SY
5	Remove Combination Curb and Gutter	611.00	LF
6	Combination Concrete Class 47B-4000 Curb and Gutter	624.00	LF
7	4" Concrete Class 47B-3000 Sidewalk	889.00	SY
8	6" Concrete Class 47B-3000 Sidewalk	37.00	SY
9	4" Concrete Class 47B-3000 Slab-on-Grade with Woven Wire Mesh (W.W.M.) and Building Ties	45.00	SY
10	Detectable Warning Panel	48.00	SF
11	Remove Recreational Area (Inc. Removal & Disposal of Play Equipment)	38.00	SY
12	Install Sign, Structure and Foundation	2.00	EA
13	Pavement Striping Removal	691.00	LF
14	Pavement Symbol Removal	3.00	EA
15	4" White Permanent Pavement Marking	630.00	LF
16	12" White Permanent Pavement Marking	260.00	LF
17	Accessible Parking Pavement Symbol	2.00	EA

PROJECT TIME COMPLETION PERIOD

It is anticipated that the Contractors Notice to Proceed may be issued on or about sixty (60) calendar days after the advertised bid opening date. Time is of the essence. Contractor shall substantially complete the work no later than May 27, 2015 from the issuance date on the official Notice to Proceed.

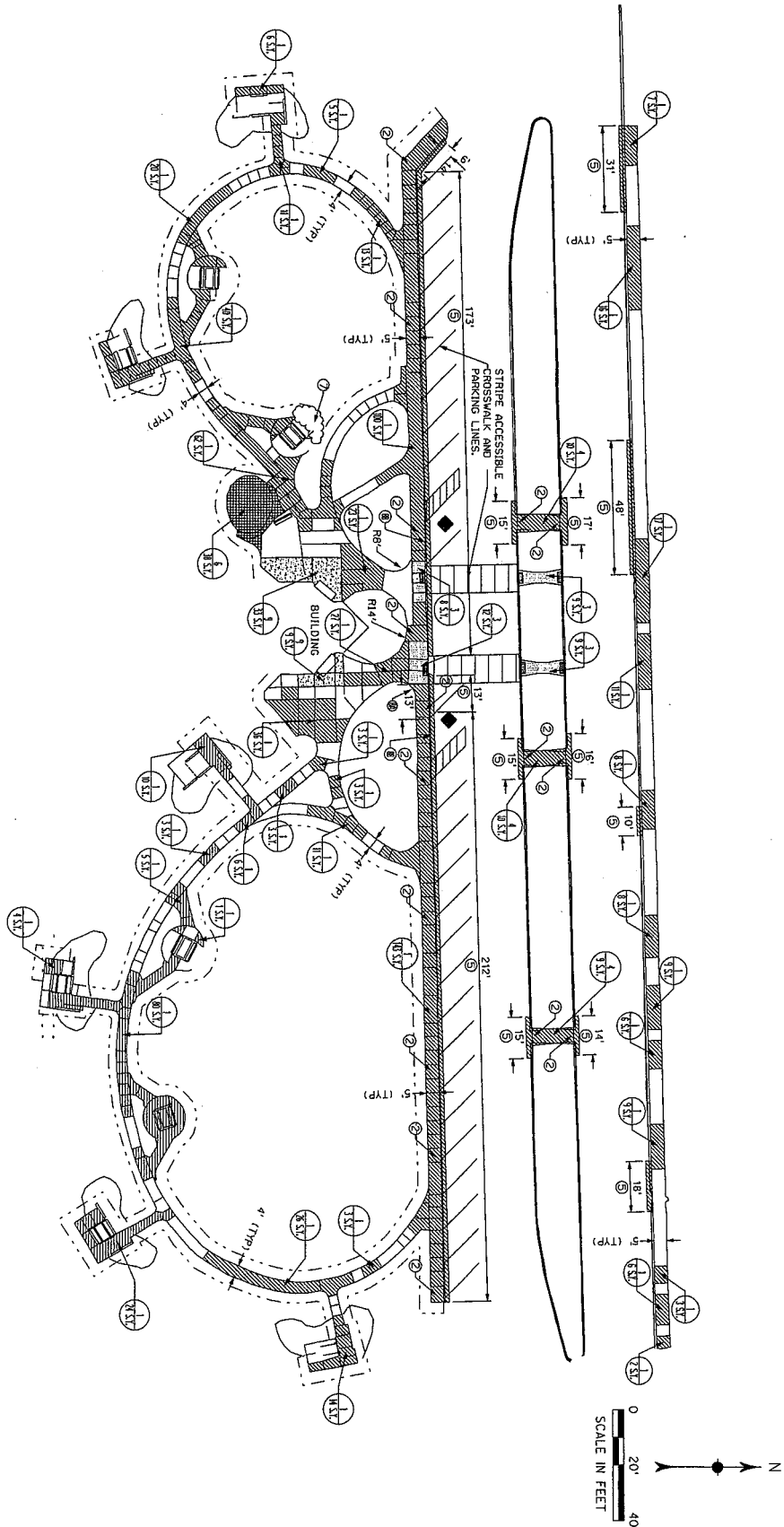

LEGEND:

	SIDEWALK/CURB AND GUTTER REMOVAL
	RECREATIONAL USE AREA REMOVAL
	CONSTRUCT ADA RAMP

- REFERENCED LAYOUT NOTES:**
1. REMOVE AND RECONSTRUCT 4" P.C.C. SIDEWALK.
 2. REMOVE AND RECONSTRUCT 4" P.C.C. GUTTER.
 3. CONSTRUCT ADA CURB RAMP.
 4. SEE DETAIL 2 ON SHEET C2.1.
 5. REMOVE EXISTING SIDEWALK, CURB AND GUTTER.
 6. REMOVE EXISTING SIDEWALK, CURB AND GUTTER.
 7. TRIM SHRUBBERY.
 8. REMOVE RECREATIONAL USE AREA.
 9. RECONSTRUCT ADA ACCESSIBLE PARKING SIGN.
 10. RECONSTRUCT ADA ACCESSIBLE PARKING SIGN.
 11. REMOVE AND RECONSTRUCT 4" P.C.C. SLAB WITH M.W.M. ADJACENT TO BUILDING.

* ALL SHOWN PAVEMENT MARKINGS ARE TO BE PAINTED.
 * ALL PLOTTING TABLES, BENCHES AND SIGNS ARE TO REMAIN IN PLACE. REPLACE ONLY SIDEWALK AS INDICATED.

PROJECT NO. 18004
 ADDRESS 46701
 SHEET C11
 46701

NDOR ADA UPGRADES
SEGMENT ONE - AFE W-002
 VARIOUS SITES
 CLIENT NEBRASKA DEPARTMENT OF ROADS
 46701 - YORK EB RA
 CIVIL SITE PLAN

DESIGNED BY	DATE
DRAWN BY	DATE
CHECKED BY	DATE
APPROVED BY	DATE

This drawing is being made available by the contractor for use on this project in accordance with the contract. The engineer assumes no liability for any use of this drawing or any part thereof that is not in accordance with the terms of the above agreement.

hgm
 ASSOCIATES INC.
 ENGINEERING ARCHITECTURE SURVEYING
 council bluffs omaha



- * ALL SHOWN PAVEMENT MARKINGS ARE TO BE PAINTED.
 * ALL PICNIC TABLES, BENCHES AND SHELTERS ARE TO REMAIN IN PLACE. REPLACE ONLY SIDEWALK AS INDICATED.
- REFERENCED LAYOUT NOTES: (X)
1. REMOVE AND RECONSTRUCT 4" P.C.C. SIDEWALK. MATCH PROPOSED SIDEWALK TO EXISTING CURB. SEE DETAIL 2 ON SHEET C2-1.
 2. CONSTRUCT ADA CURB RAMP. SEE DETAIL 3 ON SHEET C2-1.
 3. REMOVE EXISTING SIDEWALK.
 4. REMOVE AND RECONSTRUCT CURB AND GUTTER. SEE DETAIL 42 ON SHEET C2-1.
 5. REMOVE EXISTING SIDEWALK.
 6. RECONSTRUCT ADA RAMP. SEE DETAIL 1 ON SHEET C2-3.
 7. TRIM SHRUBBERY.
 - 8A. REMOVE ACCESSIBLE PARKING SIGN. SEE DETAIL 1 ON SHEET C2-3.
 - 8B. NEW LOCATION FOR ACCESSIBLE PARKING SIGN. REMOVE AND RECONSTRUCT 4" P.C.C. SLAB WITH W.W.M. ADJACENT TO BUILDING.
 - 9.

LEGEND:

- SIDEWALK/CURB AND GUTTER REMOVAL
- RECREATIONAL USE AREA REMOVAL
- CONSTRUCT ADA RAMP

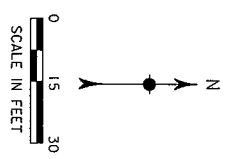
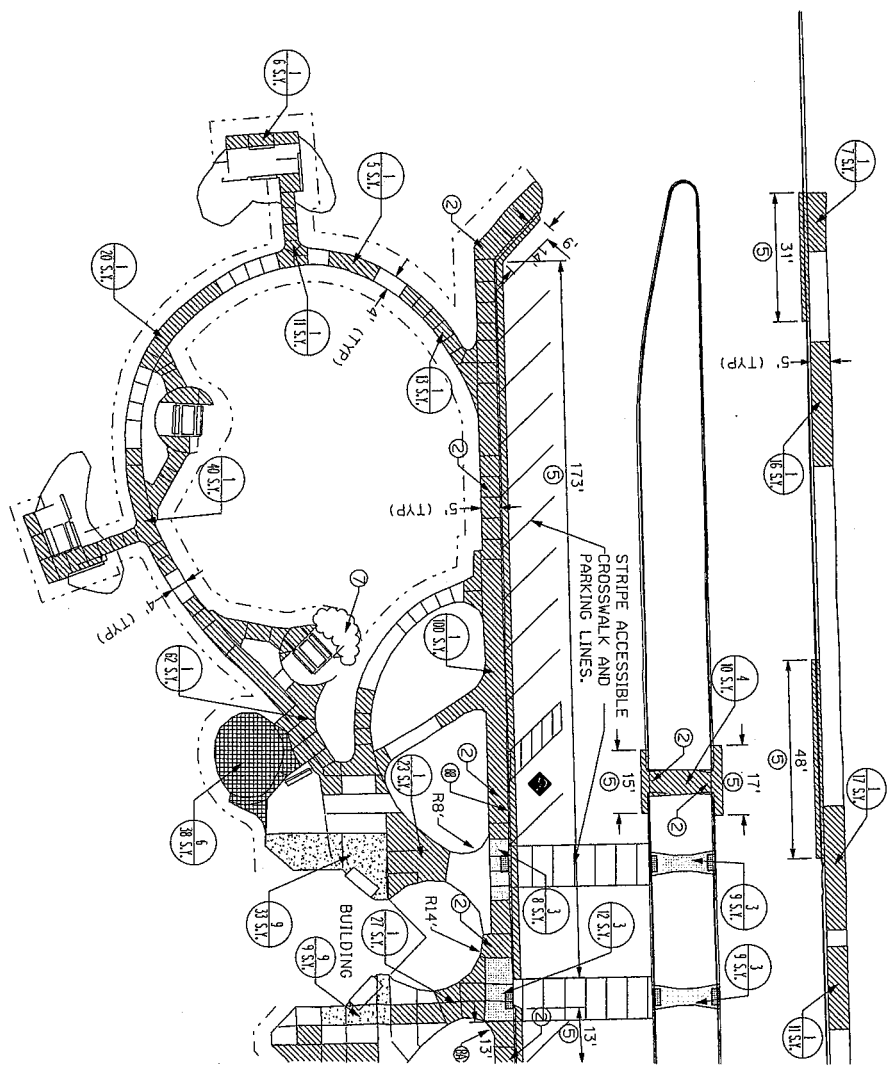

project no. 180014
 ADDENDUM 1
 sheet C12
 46701

project NDOR ADA UPGRADES
 SEGMENT ONE - AFE W-002
 VARIOUS SITES
 client NEBRASKA DEPARTMENT OF ROADS
 46701 - YORK EB RA
 sheet CIVIL SITE PLAN

DESIGNED	DATE	REVISION	SITE
DRAWN			
DESIGNED			
APPROVED			
DATE			

This drawing is being made available to high associated inc. for use on this project in accordance with high associated inc. agreement for professional services. high associated inc. assumes no liability for any use of this drawing or any part thereof except in accordance with the terms of the above agreement.

hgm
 ASSOCIATES INC.
 ENGINEERING ARCHITECTURE SURVEYING
 council bluffs omaha

