



PROJECT: Cross County School – Shop Addition **PROJECT NO.** L14057
FROM: BVH Architects **DATE:** 8/29/2014
TO: All Bidders **ADDENDUM NO.** 1

This Addendum is issued by the Architect to all bidders of record prior to receipt of proposals. Bidders shall acknowledge receipt of this addendum by so indicating on the Proposal Form. Failure to do so may subject Bidder to disqualification.

All information and instructions given herein shall become a part of the Contract Documents.

GENERAL

1. The following substitution requests are approved for bidding:
 - a. MarcStone, LLC – 034500 Architectural Precast
 - b. Mule-Hide Products Co., Inc – 075300 Elastomeric Membrane Roofing
2. See the attached pre-bid meeting sign in sheet.
3. Construction Staging available on the north side of the building. Please maintain access to all dumpsters.

PROJECT MANUAL

1. Geotechnical Engineering Report
 - a. Over excavation should be 24" below the typical bottom of footing 96'-0". Over excavation at detail 20 on S3.1 shall extend 24" below the bottom of extended footing.
2. Add the following spec sections to the project manual (see attached sheets):
 - a. Section 071300 – Sheet Waterproofing
 - b. Section 081416 – Flush Wood Doors
3. Spec Section 42000.2.02.A: Delete galvanized finish.

DRAWINGS

1. A1.1 – First Floor Plan
 - a. A1 First Floor Plan
 1. Adjust note for 'New 5" Conc Slab" to read 'New 6" Conc Slab, See Civil.'
2. A1.3 – Roof Plan
 - a. A1 Roof Plan
 1. See attached updated drawing ADD1.1 to infill the roof where exhaust hood is being removed.
 - b. L20 Existing Roof Infill – NEW DETAIL
 1. See attached new drawing ADD1.2 to infill the existing roof.
 - c. Sheet A1.3 between A1.4 and A2.1 is a duplicate and can be deleted.

3. A6.1 – Section Details
 - a. See attached Full Sheet replacement A6.1R.
 - b. K20 Window Jamb Detail – NEW DETAIL
 1. See attached new drawing ADD1.3 at new window jambs.
4. A9.1 – Room Finish Schedule and Materials List
 - a. Room Finish Schedule
 1. Room 101 – Office – Floor finish to be CPT-1 in lieu of CPT-2.

CIVIL

1. C1.1 – Demolition Plan
 - a. See attached updated civil drawing.
2. C1.2 – Layout/Utility Plan
 - a. See attached updated civil drawing.

MECHANICAL/ELECTRICAL

1. See attached Mechanical/Electrical Addendum sheet.

END OF ADDENDUM



PRE-BID MEETING SIGN IN SHEET
 Cross County Public School – Shop Addition
 L14057
 08.25.14

	NAME	COMPANY	PHONE	EMAIL
1.	John Bierman	Bierman Contracting	402-564-4749	john@bierman-inc.com
2.	Ty Stahn	McIlroy & Co	308-946-3182	mcilroyco@guestoffice.net
3.	Chuck Lacey	Lacey Construction	402-443-1112	chuck@laceyinc.com
4.	ZACH MART	ELKHORN WEST CONSTRUCTION	402-315-9557	zach@elkhornwest.com
5.	STEVE BEALL	CENTRAL CONTRACTING	308-234-2421	sbeall@centralcontracting.net
6.	Dave Siegel	Middletown Electric	308-382-2550	dsiegel@middletownelectric.com
7.	Chris Wissing	Lacey Construction	308-384-2866	chrisw@laceygc.com
8.	Jesse Spike	Access Electrical Systems	308-293-2727	jesse@accesselectricalsystemsinc.com
9.	Ted Mieth	Heartland Electric	308-389-7473	ted.mieth@chiefind.com
10.	LOS SWANSON	BULLSEYE'S FIRE SPRINKLER	(402) 371-8754	BULLSEYE@COMPPOINT.COM
11.	Brandon Rystrom	MERIT MECHANICAL	402-368-7705	brystrom@cableone.net
12.	JASON WEIDNER	MERIT MECHANICAL INC	402-368-7705	jweidner@cableone.net
13.	Nathan Heng	Control Management Inc	402-943-6792	nathan@cmioma.com

PRE-BID MEETING SIGN IN SHEET
 Cross County Public School – Shop Addition
 L14057
 08.25.14

	NAME	COMPANY	PHONE	EMAIL
14.	Bruce Brauer	B-D Construction	402-564-1225	bdmail@bdconstructioninc.com
15.	JUSTIN HUETTER	CHEEVER CONSTRUCTION	402-477-6745	jhutter@cheeverconstruction.com
16.				
17.				
18.				
19.				
20.				
21.				
22.				
23.				
24.				
25.				
26.				

SECTION 071300
SHEET WATERPROOFING

PART 1 GENERAL

1.01 SECTION INCLUDES

- A. Sheet membrane waterproofing.
- B. Cant strips and other accessories.

1.02 RELATED REQUIREMENTS

- A. Section 042000 - Unit Masonry: Masonry substrate and masonry joints prepared to receive flashings.
- B. Section 072100 - Thermal Insulation: Perimeter foundation insulation boards.
- C. Section 079005 - Joint Sealers: Sealant for joints in substrates.

1.03 REFERENCE STANDARDS

- A. ASTM D412 - Standard Test Methods for Vulcanized Rubber and Thermoplastic Elastomers-Tension; 2006a (Reapproved 2013).
- B. ASTM D570 - Standard Test Method for Water Absorption of Plastics; 1998 (Reapproved 2010).
- C. ASTM D2240 - Standard Test Method For Rubber Property--Durometer Hardness; 2005 (Reapproved 2010).
- D. ASTM D5295 - Standard Guide for Preparation of Concrete Surfaces for Adhered (Bonded) Membrane Waterproofing Systems; 2000 (Reapproved 2006).
- E. ASTM E96/E96M - Standard Test Methods For Water Vapor Transmission of Materials; 2013.
- F. NRCA ML104 - The NRCA Roofing and Waterproofing Manual; National Roofing Contractors Association; Fifth Edition, with interim updates.
- G. NRCA MS108 - The NRCA Waterproofing and Dampproofing Manual; National Roofing Contractors Association; Third Edition.

1.04 SUBMITTALS

- A. See Section 013000 - Administrative Requirements, for submittal procedures.
- B. Product Data: Provide data for membrane and all accessory items.
- C. Shop Drawings: Indicate special joint or termination conditions and conditions of interface with other materials.
- D. Manufacturer's Installation Instructions: Indicate special procedures.
- E. Warranty: Submit manufacturer warranty and ensure forms have been completed in Owner's name and registered with manufacturer. Submit per Section 017800.

1.05 QUALITY ASSURANCE

- A. Membrane Manufacturer Qualifications: Company specializing in waterproofing sheet membranes with 20 years experience.
- B. Installer Qualifications: Company specializing in performing the work of this section with minimum 5 years experience.

1.06 FIELD CONDITIONS

- A. Maintain ambient temperatures above 40 degrees F for 24 hours before and during application and until liquid or mastic accessories have cured unless otherwise indicated by manufacturer.

1.07 WARRANTY

- A. See Section 017800 - Closeout Submittals, for additional warranty requirements.

- B. Contractor shall correct defective Work within a five year period after Date of Substantial Completion; remove and replace materials concealing waterproofing at no extra cost to Owner.

PART 2 PRODUCTS

2.01 MANUFACTURERS

- A. Basis of Design - W.R. Grace & Company; Product Bituthene System 4000.
- B. Other Acceptable Laminated Composite Manufacturers:
 - 1. W.R. Meadows, Inc.
 - 2. Pecora Corp.
 - 3. Substitutions: See Section 016000 - Product Requirements.

2.02 MEMBRANE MATERIALS

- A. Composite Laminate Membrane: Comprised of 0.056 inch thickness of rubberized asphalt and a 0.004 inch thickness of cross-laminated, high density polyethylene film; 0.060 inch total thickness.
 - 1. Capable of resisting water head of 231 feet and preventing moisture migration to interior.
 - 2. Tensile Strength: 325 psi, measured in accordance with ASTM D 412.
 - 3. Ultimate Elongation: 300 percent, measured in accordance with ASTM D 412.
 - 4. Water Absorption: 0.1 percent increase in weight, maximum, measured in accordance with ASTM D 570, 24 hour immersion.
 - 5. Water Vapor Permeability: 0.05 perm inch, measured in accordance with ASTM E 96/E 96M.
- B. Membrane Sealant: As recommended by membrane manufacturer.
- C. Surface Conditioner: Water-based type, compatible with membrane.
- D. Provide release sheet at adhesive side of membrane to be removed during installation.
- E. Miscellaneous Materials: Surface conditioner, mastic, liquid membrane, tape and accessories acceptable to manufacturer of sheet membrane waterproofing.
- F. Thinner and Cleaner: As recommended by adhesive manufacturer, compatible with sheet membrane.

PART 3 EXECUTION

3.01 EXAMINATION

- A. Verify existing conditions before starting work.
- B. Verify substrate surfaces are durable; free of matter detrimental to adhesion or application of waterproofing system.
- C. Verify that items that penetrate surfaces to receive waterproofing are securely installed.

3.02 PREPARATION

- A. Protect adjacent surfaces not designated to receive waterproofing.
- B. Clean and prepare surfaces to receive waterproofing in accordance with manufacturer's instructions.
- C. Do not apply waterproofing to surfaces unacceptable to membrane manufacturer.
- D. Seal cracks and joints with sealant using depth to width ratio in accordance with Section 079005.
- E. Apply surface conditioner at a rate recommended by manufacturer. Protect conditioner from rain or frost until dry.

3.03 INSTALLATION - MEMBRANE

- A. Install membrane waterproofing in accordance with manufacturer's instructions.
- B. Roll out membrane. Minimize wrinkles and bubbles.
- C. Self-Adhering Membrane: Remove release paper layer. Roll out on substrate with a mechanical roller to encourage full contact bond.

- D. Vertical Surfaces: Terminate membrane at top of wall at just below grade level. Terminate membrane at base of wall by extending membrane onto and over top of footing.
- E. Overlap edges and ends and seal by method recommended by manufacturer, minimum 3 inches. Seal permanently waterproof. Apply uniform bead of sealant to joint edge.
- F. Corners: Provide additional 12 inch wide strip of membrane centered at both inside and outside corners to ensure 2-ply coverage at all corners.
- G. Joints: Reinforce membrane with multiple thickness of membrane material over joints, whether joints are static or dynamic.
- H. Seal items penetrating through membrane with flexible flashings. Seal watertight to membrane.
- I. Seal membrane terminations tight to adjoining surfaces.

3.04 PROTECTION

- A. Protect installed membrane from subsequent construction activities until membrane is covered or back-filled.

END OF SECTION

SECTION 081416
FLUSH WOOD DOORS

PART 1 GENERAL

1.01 SECTION INCLUDES

- A. Veneer wood doors; flush configuration; fire rated and non-rated.

1.02 RELATED REQUIREMENTS

- A. Section 081113 - Hollow Metal Doors and Frames.
- B. Section 087100 - Door Hardware.
- C. Section 088000 - Glazing.

1.03 REFERENCE STANDARDS

- A. ASTM E 336 - Standard Test Method for Measurement of Airborne Sound Insulation in Buildings; 1997.
- B. AWI (QCP) - Quality Certification Program, www.awiqcp.org; current edition at www.awiqcp.org.
- C. AWI/AWMAC/WI (AWS) - Architectural Woodwork Standards; 2009.
- D. ICC (IBC) - International Building Code; 2012.
- E. ITS (DIR) - Directory of Listed Products; Intertek Testing Services NA, Inc.; current edition.
- F. NFPA 80 - Standard for Fire Doors and Other Opening Protectives; 2013.
- G. NFPA 252 - Standard Methods of Fire Tests of Door Assemblies; National Fire Protection Association; 2012.
- H. UL (BMD) - Building Materials Directory; Underwriters Laboratories Inc.; current edition.
- I. UL 10C - Standard for Positive Pressure Fire Tests of Door Assemblies; Current Edition, Including All Revisions.
- J. WDMA I.S.1-A - Architectural Wood Flush Doors; Window and Door Manufacturers Association; 2011.

1.04 SUBMITTALS

- A. See Section 013000 - Administrative Requirements for submittal procedures.
- B. Product Data: Indicate door core materials and construction; veneer species, type and characteristics.
- C. Shop Drawings: Illustrate door opening criteria, elevations, sizes, types, swings, undercuts required, special beveling, special blocking for hardware, factory machining criteria, factory finishing criteria, identify cutouts for glazing.
- D. Samples: Submit two sets of available stain colors and sheen on specified wood species, 6 x 6 inch in size for selection by Architect.
- E. Manufacturer's Installation Instructions: Indicate special installation instructions.
- F. Operations and Maintenance Information per Section 017800.
- G. Warranty, executed in Owner's name per Section 017800.

1.05 QUALITY ASSURANCE

- A. Perform work in accordance with AWI Architectural Woodwork Quality Standards Illustrated, Section 1300, Premium Grade.
- B. Manufacturer Qualifications: Company specializing in manufacturing the products specified in this section with minimum five years of documented experience.

1.06 REGULATORY REQUIREMENTS

- A. Fire Door Construction: Conform to NFPA 252.

1. Listed and classified by UL as suitable to the purpose specified and indicated.
- B. Installed Fire Rated Door Assembly: Conform to NFPA 80 for fire rated class as indicated.

1.07 DELIVERY, STORAGE, AND HANDLING

- A. Package, deliver and store doors in accordance with specified quality standard.
- B. Accept doors on site in manufacturer's packaging. Inspect for damage.
- C. Protect doors with resilient packaging sealed with heat shrunk plastic. Do not store in damp or wet areas; or in areas where sunlight might bleach veneer. Seal top and bottom edges with tinted sealer if stored more than one week. Break seal on site to permit ventilation.

1.08 PROJECT CONDITIONS

- A. Coordinate the work with door opening construction, door frame and door hardware installation.

1.09 WARRANTY

- A. See Section 017800 - Closeout Submittals for additional warranty requirements.
- B. Interior Doors: Provide manufacturer's warranty for the life of the installation.
- C. Provide warranty for the following term:
 1. Interior Doors: Life of installation.
- D. Include coverage for delamination of veneer, warping beyond specified installation tolerances, defective materials, and telegraphing core construction.

PART 2 PRODUCTS

2.01 MANUFACTURERS

- A. Approved Manufacturer: Basis of Design.
 1. Marshfield Door Systems-Signature Series.
- B. Other Approved Manufacturers:
 1. Algoma Hardwoods, Inc.
 2. VT Industries.
 3. Graham Wood Doors: www.grahamdoors.com.
 4. Eggers Industries; www.eggersindustries.com.
 5. Substitutions: See Section 016000 - Product Requirements.

2.02 DOOR TYPES

- A. All Doors: See drawings for locations and additional requirements.
 1. Quality Level: Premium Grade, Heavy Duty performance, in accordance with WDMA I.S.1-A.
 2. Wood Veneer Faced Doors: 5-ply unless otherwise indicated. Solid core construction.
- B. Interior Doors: 1-3/4 inches thick unless otherwise indicated; flush construction.
 1. Provide solid core doors at all locations.
 2. Fire Rated Doors: Tested to ratings indicated on Door Schedule in accordance with International Building Code ("positive pressure"); UL or WH (ITS) labeled without any visible seals when door is open.

2.03 DOOR CORES

- A. Non-Rated Solid Core Doors: structural composite lumber core (SCLC).
- B. Fire Rated Doors: AWI P-200, Section 1300, Type FD, hourly ratings as indicated.

2.04 DOOR FACINGS

- A. Interior Doors - Veneer: Premium grade wood veneer, Species - White Maple to match existing, plain sliced, with slip matched grain, for transparent finish.
- B. Facing Adhesive: Type II - water resistant.

2.05 ACCESSORIES

- A. Glazing Stops: Rolled steel channel shape, mitered corners; prepared for countersink style tamper proof screws.

2.06 DOOR CONSTRUCTION

- A. Fabricate doors in accordance with door quality standard specified.
- B. Cores Constructed with stiles and rails:
- C. Fabricate fire rated doors in accordance with UL requirements. Attach fire rating label to door.
- D. At mineral core doors provide solid blocking as required to eliminate the need for thru-bolting of hardware.
- E. Provide manufacturers standard laminated edge construction for improved screw holding capability and split resistance as compared to edges composed of a single layer of treated lumber.
- F. Provide solid blocks at lock edge for hardware reinforcement.
 - 1. Provide solid blocking for other throughbolted hardware.
- G. Fit door edge trim to edge of stiles after applying veneer facing.
- H. Bonding: Stiles and rails shall be bonded to core, then entire unit abrasive planed before veneering.
- I. Edge Construction: Matching hardwood edge; 1/16th inch min. thickness.
- J. At Contractor's option, factory machine doors for hardware other than surface-mounted hardware, in accordance with hardware requirements and dimensions. Do not machine for surface hardware.
- K. Provide edge clearances in accordance with the quality standard specified.

2.07 FACTORY FINISHING - WOOD VENEER DOORS

- A. Finish work in accordance with AWI/AWMAC/WI Architectural Woodwork Standards, Section 5 - Finishing for Grade specified and as follows:
 - 1. Transparent:
 - a. System - 12, Polyurethane, Water-based.
 - b. Sheen: Satin.

PART 3 EXECUTION

3.01 EXAMINATION

- A. Verify existing conditions before starting work.
- B. Verify that opening sizes and tolerances are acceptable.
- C. Do not install doors in frame openings that are not plumb or are out-of-tolerance for size or alignment.

3.02 INSTALLATION

- A. Install doors in accordance with manufacturer's instructions and specified quality standard.
 - 1. Install fire-rated doors in accordance with NFPA 80 requirements.
- B. Factory-Finished Doors: Do not field cut or trim; if fit or clearance is not correct, replace door.
- C. Trim door height by cutting bottom edges to a maximum of 3/4 inch (19 mm).
 - 1. Trim fire door height at bottom edge only, in accordance with fire rating requirements.
- D. Use machine tools to cut or drill for hardware.
- E. Coordinate installation of doors with installation of frames and hardware.
- F. Coordinate installation of glazing.
- G. Install door louvers plumb and level.

3.03 TOLERANCES

- A. Conform to specified quality standard for fit and clearance tolerances.
- B. Conform to specified quality standard for telegraphing, warp, and squareness.

3.04 ADJUSTING

- A. Adjust doors for smooth and balanced door movement.
- B. Adjust closers for full closure.

3.05 SCHEDULE - SEE DRAWINGS

END OF SECTION



CROSS COUNTY SCHOOL - SHOP ADDITION

ADDENDUM #1 - ADD1.1

- ASI NO.:
- ADDENDUM NO.: 1
- CHANGE PROPOSAL REQUEST NO.:
- R.F.I REQUEST NO.:
- PROJECT: L14057
- PROJECT DATE: 08/11/14
- DATE ISSUED: 08/28/14

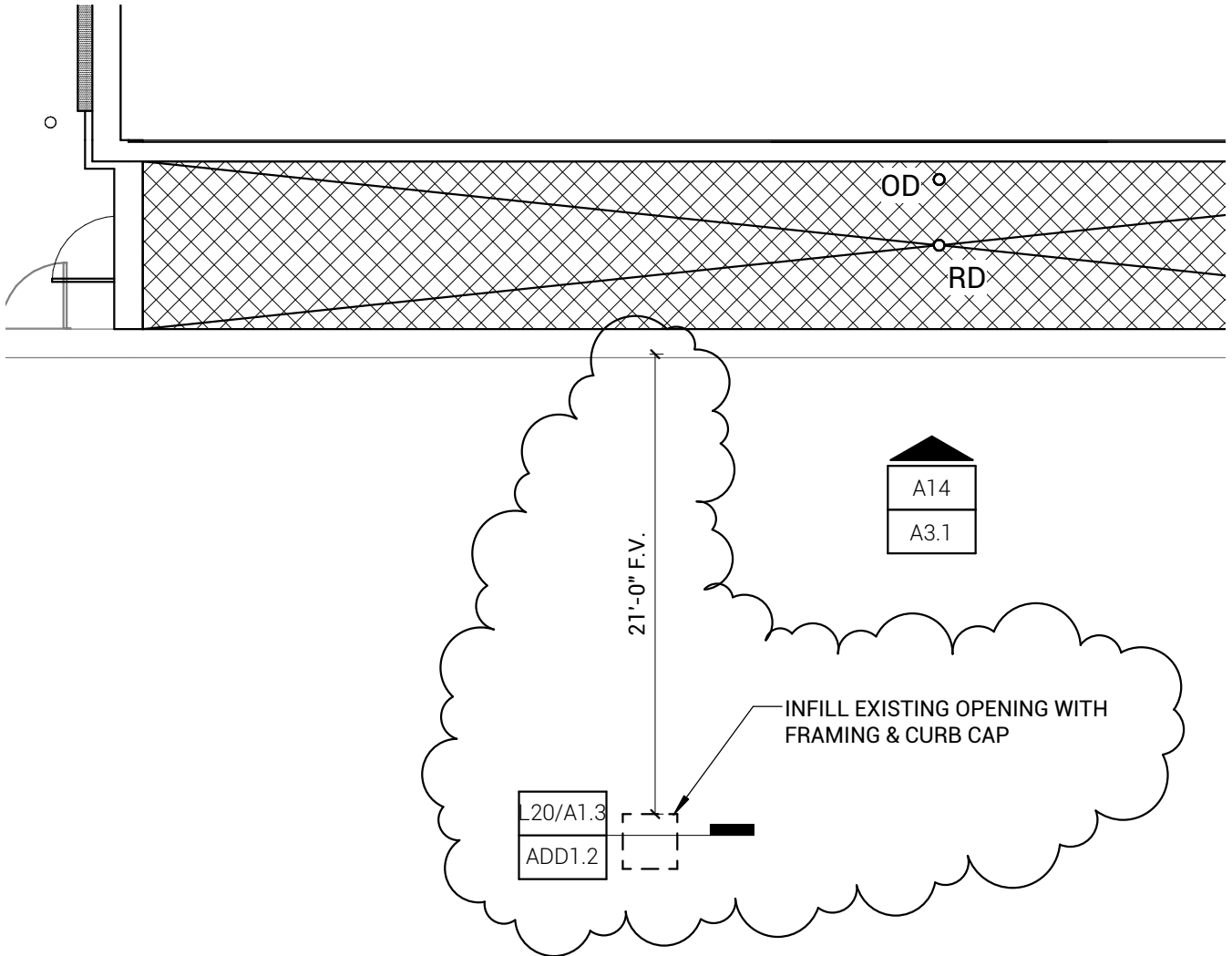

A1/A1.3 ROOF PLAN

1/8" = 1'-0"



CROSS COUNTY SCHOOL - SHOP ADDITION

ADDENDUM #1 - ADD1.2

- ASI NO.:
- ADDENDUM NO.: 1
- CHANGE PROPOSAL REQUEST NO.:
- R.F.I REQUEST NO.:
- PROJECT: L14057
- PROJECT DATE: 08/11/14
- DATE ISSUED: 08/28/14

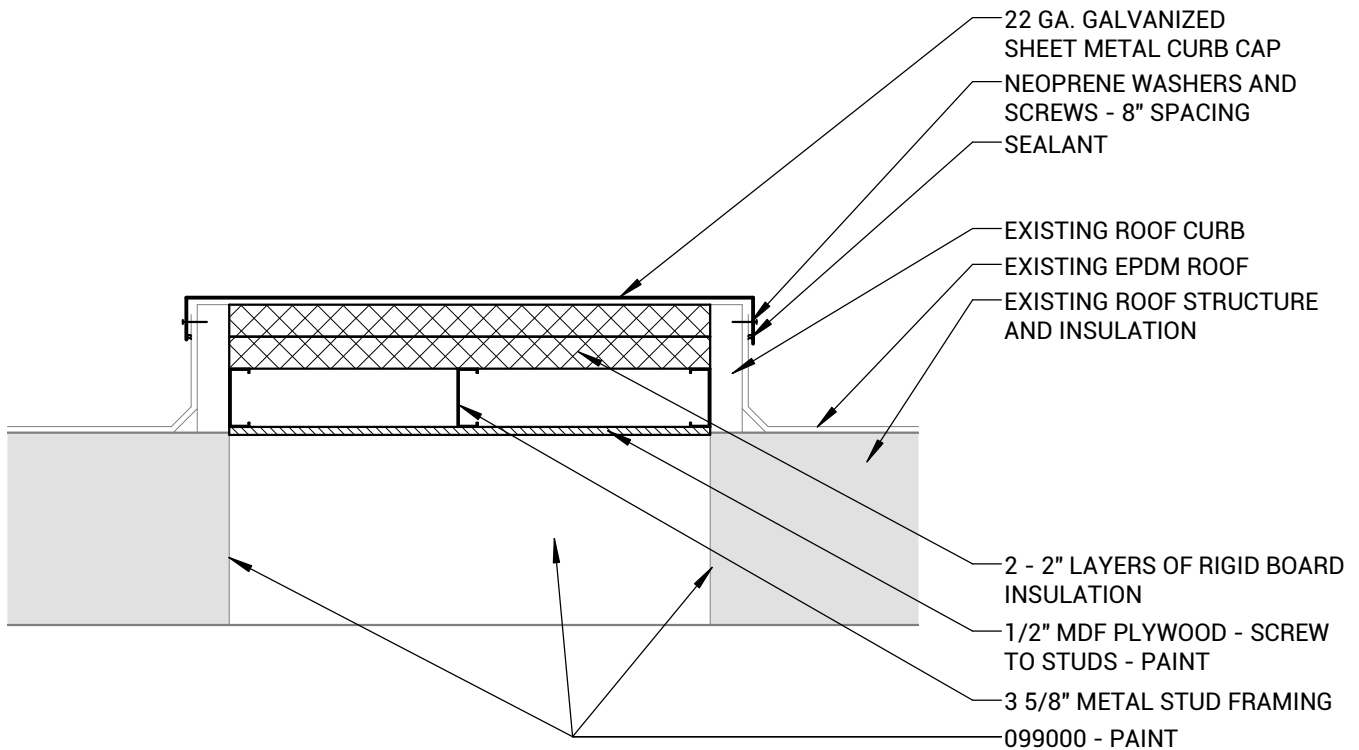

L20/A1.3 EXISTING ROOF INFILL - ADDENDUM #1

1" = 1'-0"



ARCHITECT
BARR VERMEER HAECKER ARCHITECTS
 440 N 8TH ST STE 100
 LINCOLN NE 68508
 V: 402.475.4551
 F: 402.475.0225
 bvh.com

MECHANICAL/ELECTRICAL ENGINEER
ENGINEERING TECHNOLOGIES, INC
 825 M STREET STE 200
 LINCOLN NE 68508
 V: 402.476.1273
 F: 402.476.1274
 et-engineers.com

STRUCTURAL ENGINEER
LANGE STRUCTURAL GROUP
 3616 POTOMAC LANE
 LINCOLN NE 68516
 V: 402.421.9549
 F: 402.560.9521
 langestructuralgroup.com

CIVIL ENGINEER
REGA ENGINEERING GROUP, INC
 1633 SOUTH 70TH STE 103
 LINCOLN NE 68506
 V: 402.484.7342
 F: 402.484.7344
 regaengineering.com

REVISIONS SCHEDULE		
MARK	DATE	DESCRIPTION
1	8/28/14	ADDENDUM #1

CROSS COUNTY SCHOOL - SHOP ADDITION

PROJECT: L14057 DATE: 08/11/14

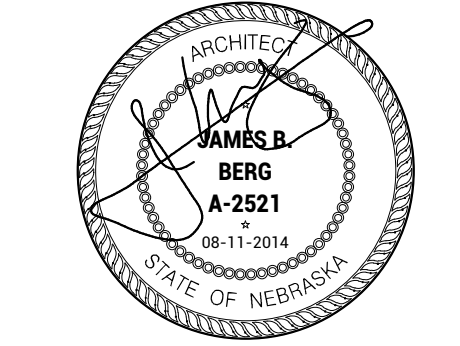

SECTION DETAILS

A6.1R

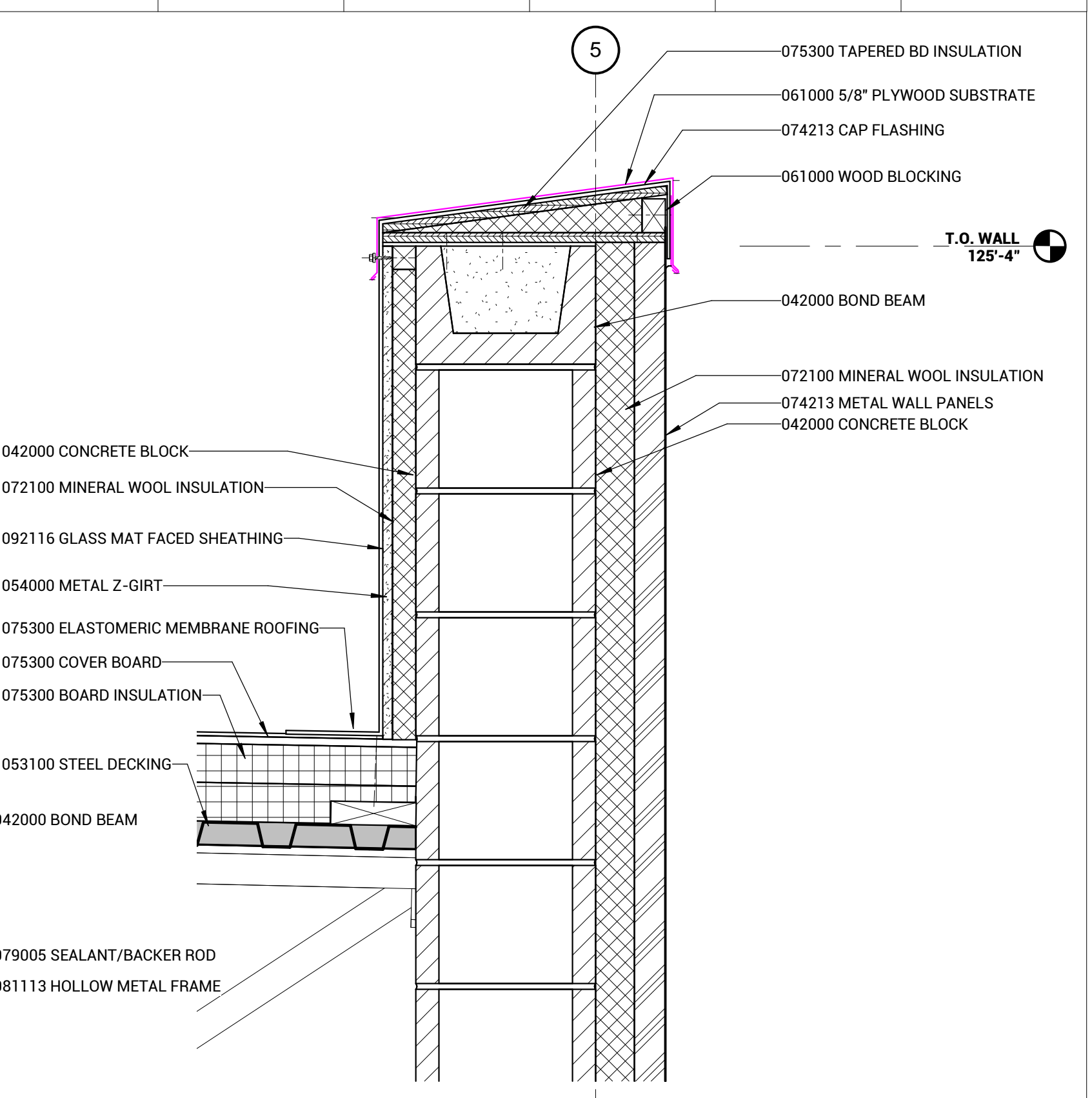

N20 SECTION DETAIL
 1 1/2" = 1'-0"

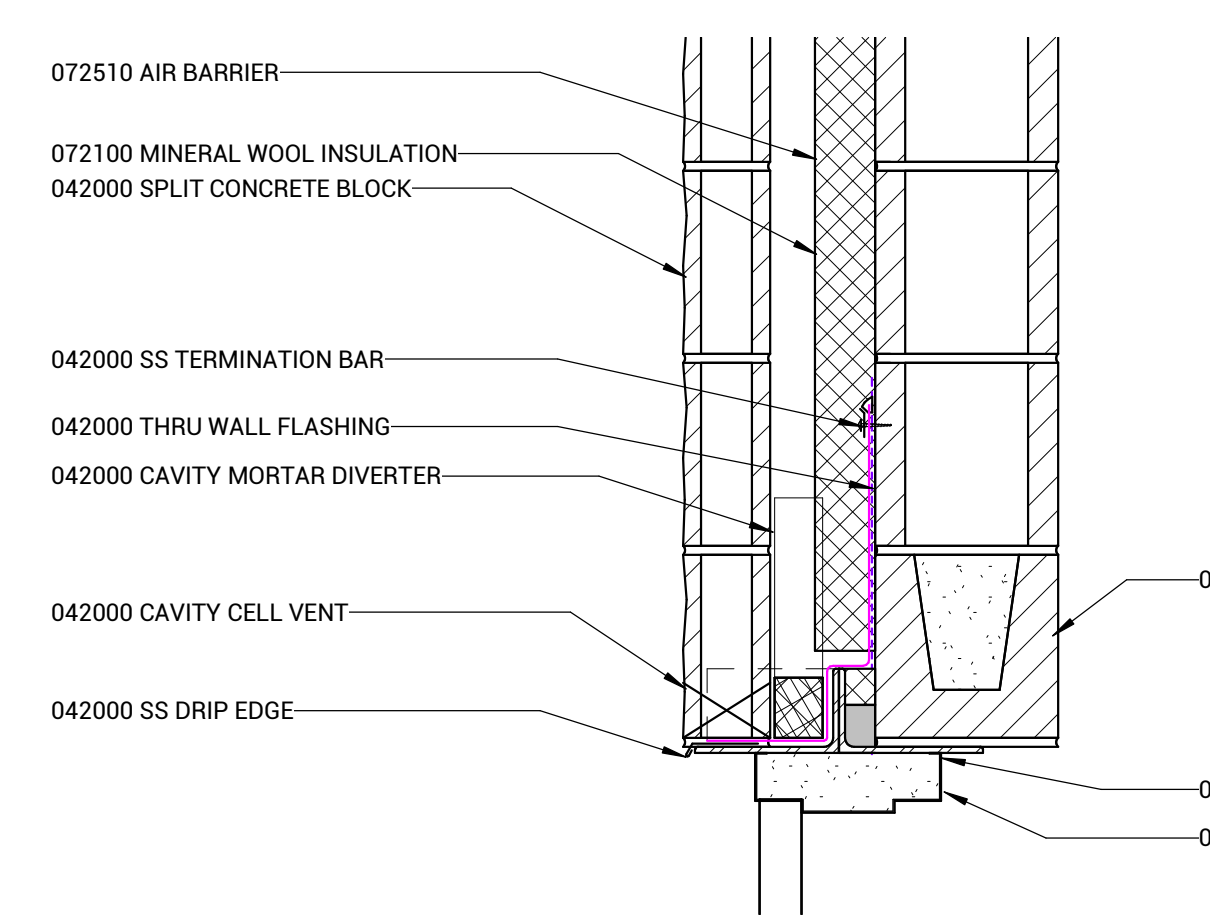

N15 SECTION DETAIL
 1 1/2" = 1'-0"

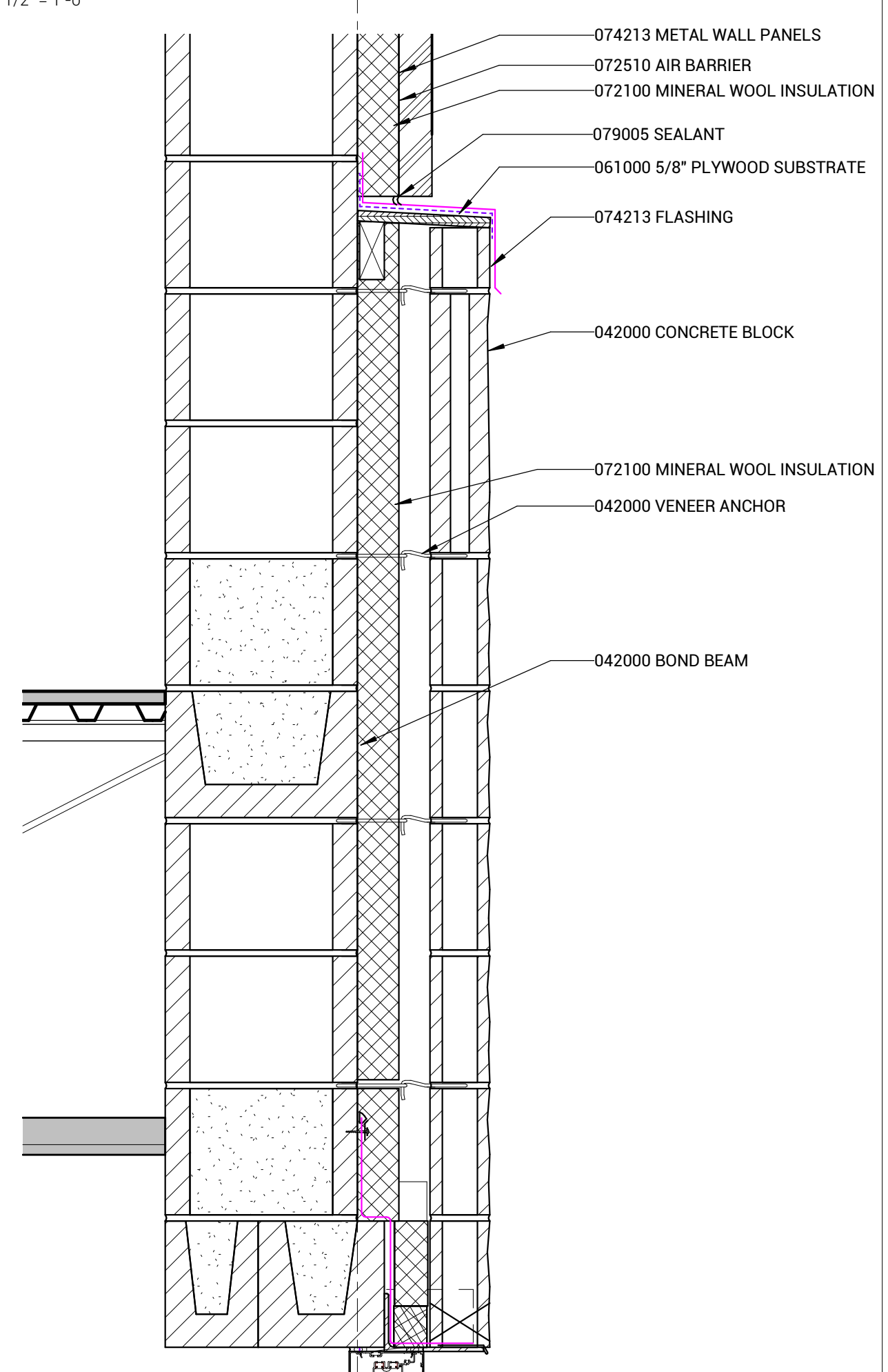

D20 SECTION DETAIL
 1 1/2" = 1'-0"

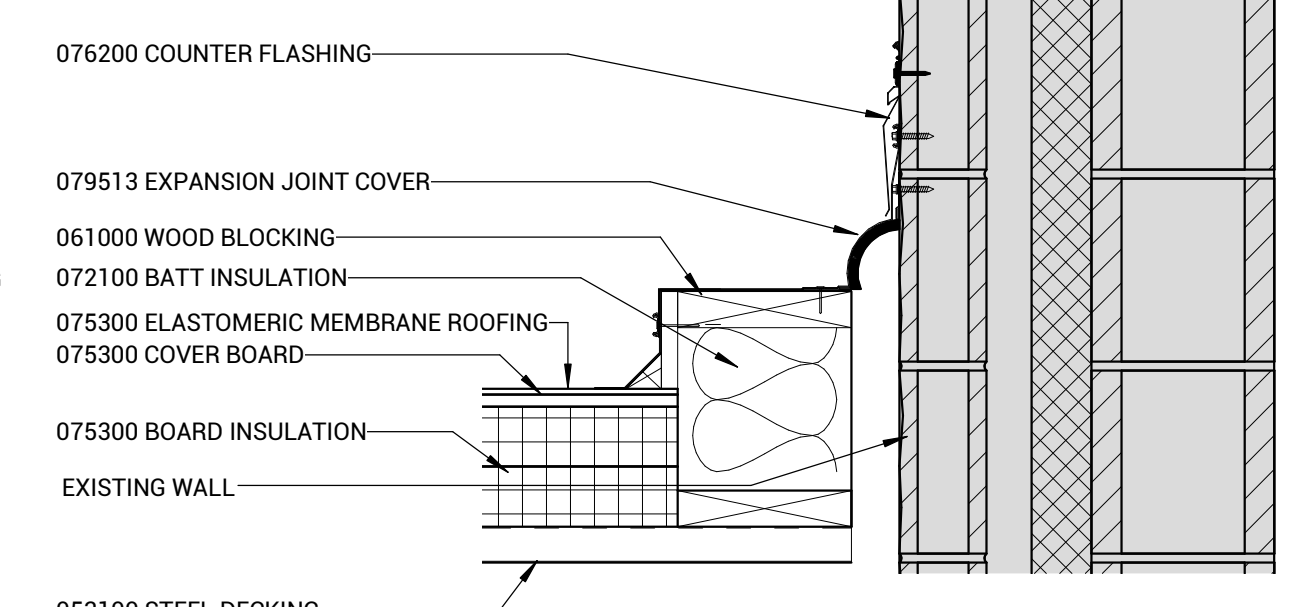

G15 SECTION DETAIL
 1 1/2" = 1'-0"

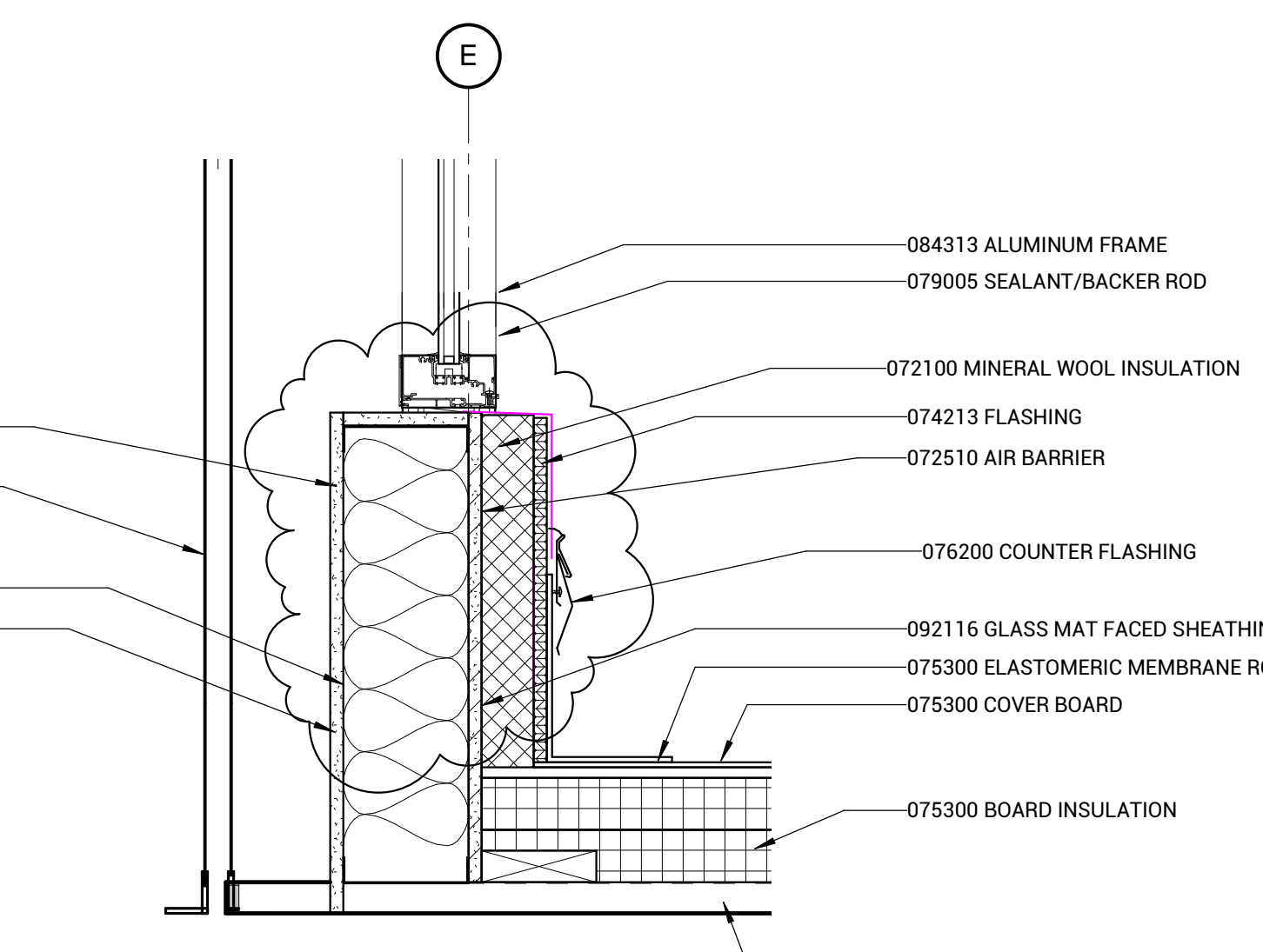

G9 SECTION DETAIL
 1 1/2" = 1'-0"

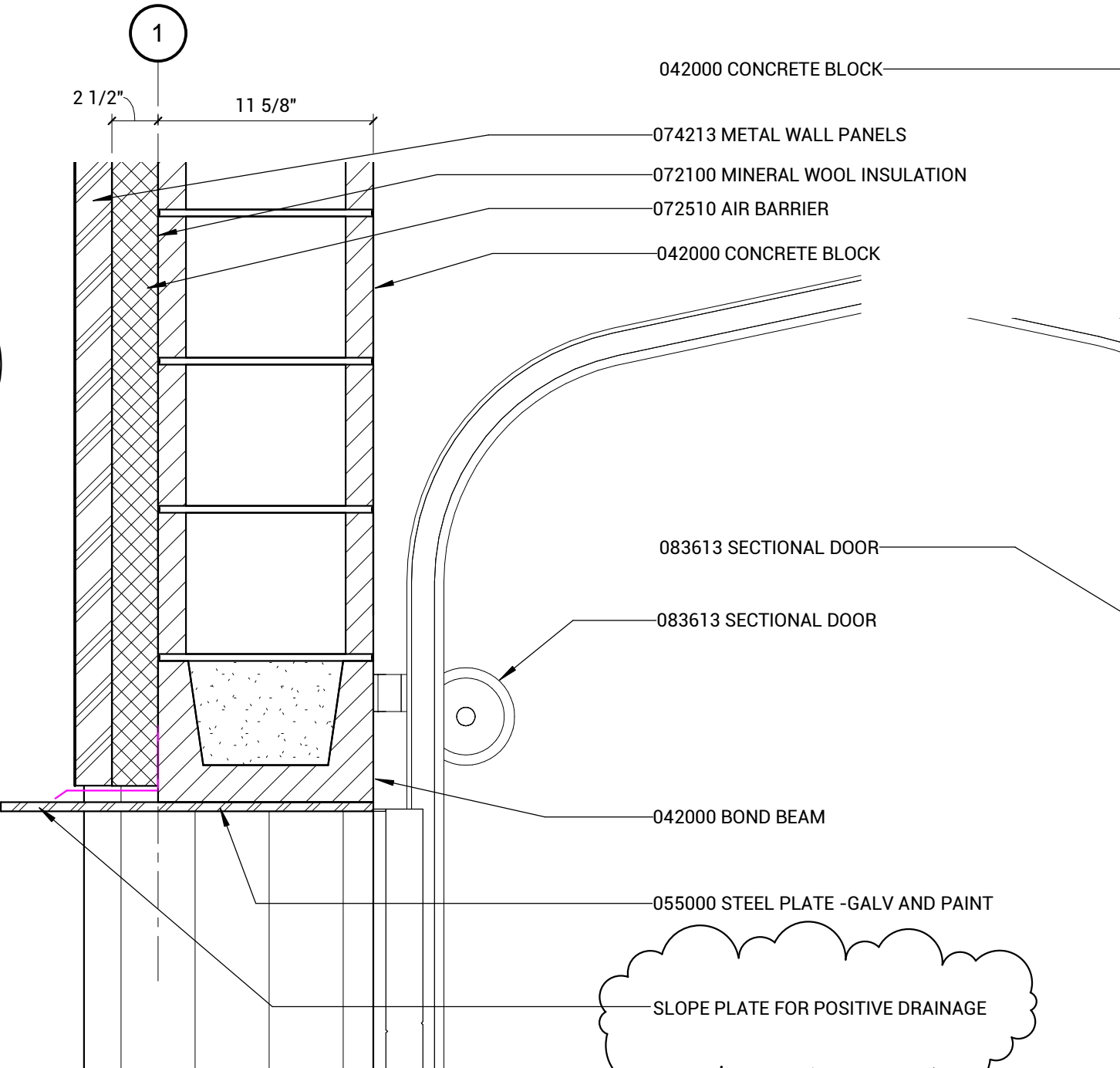

A10 SECTION DETAIL
 1 1/2" = 1'-0"

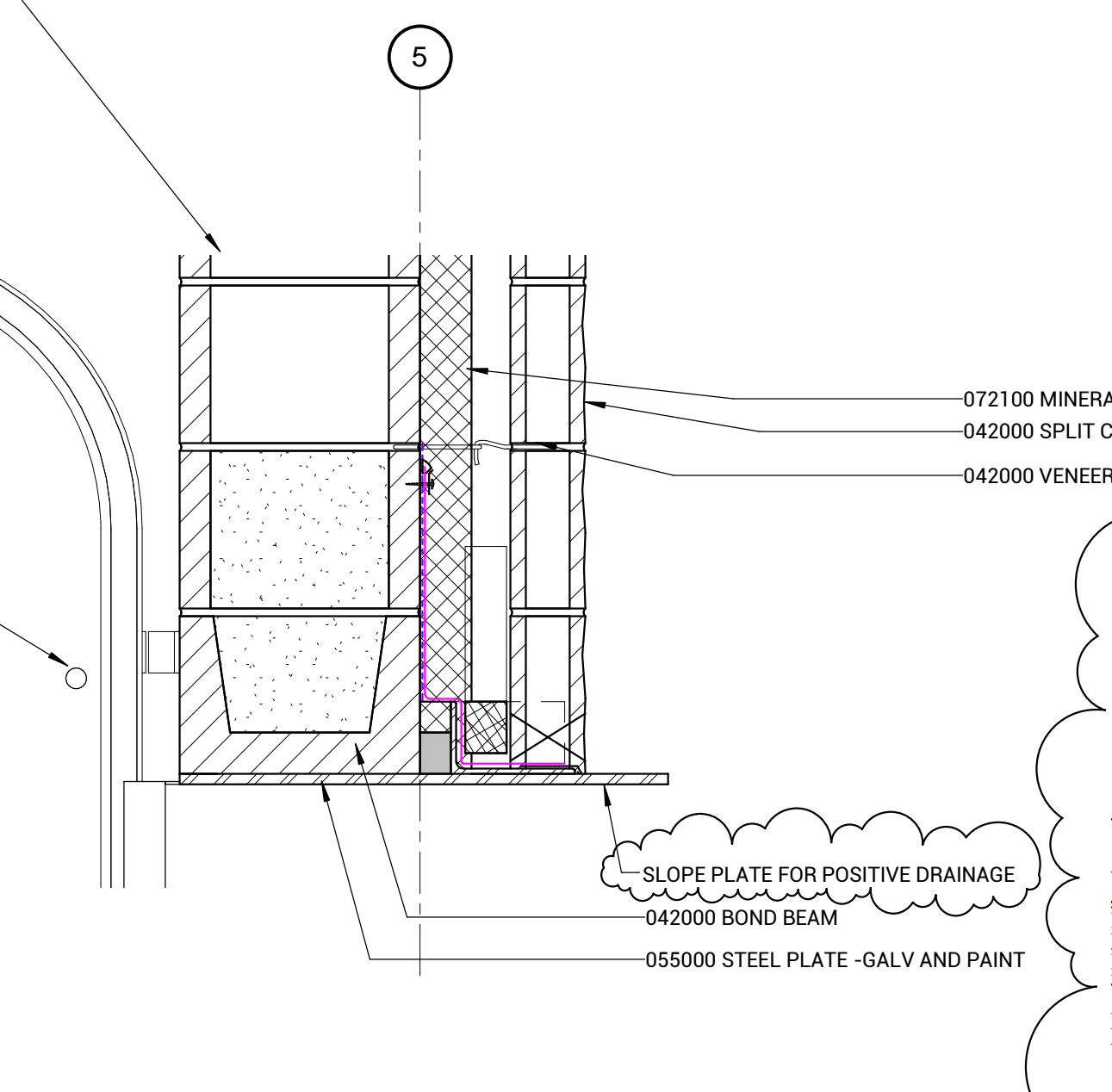

A14 SECTION DETAIL
 1 1/2" = 1'-0"

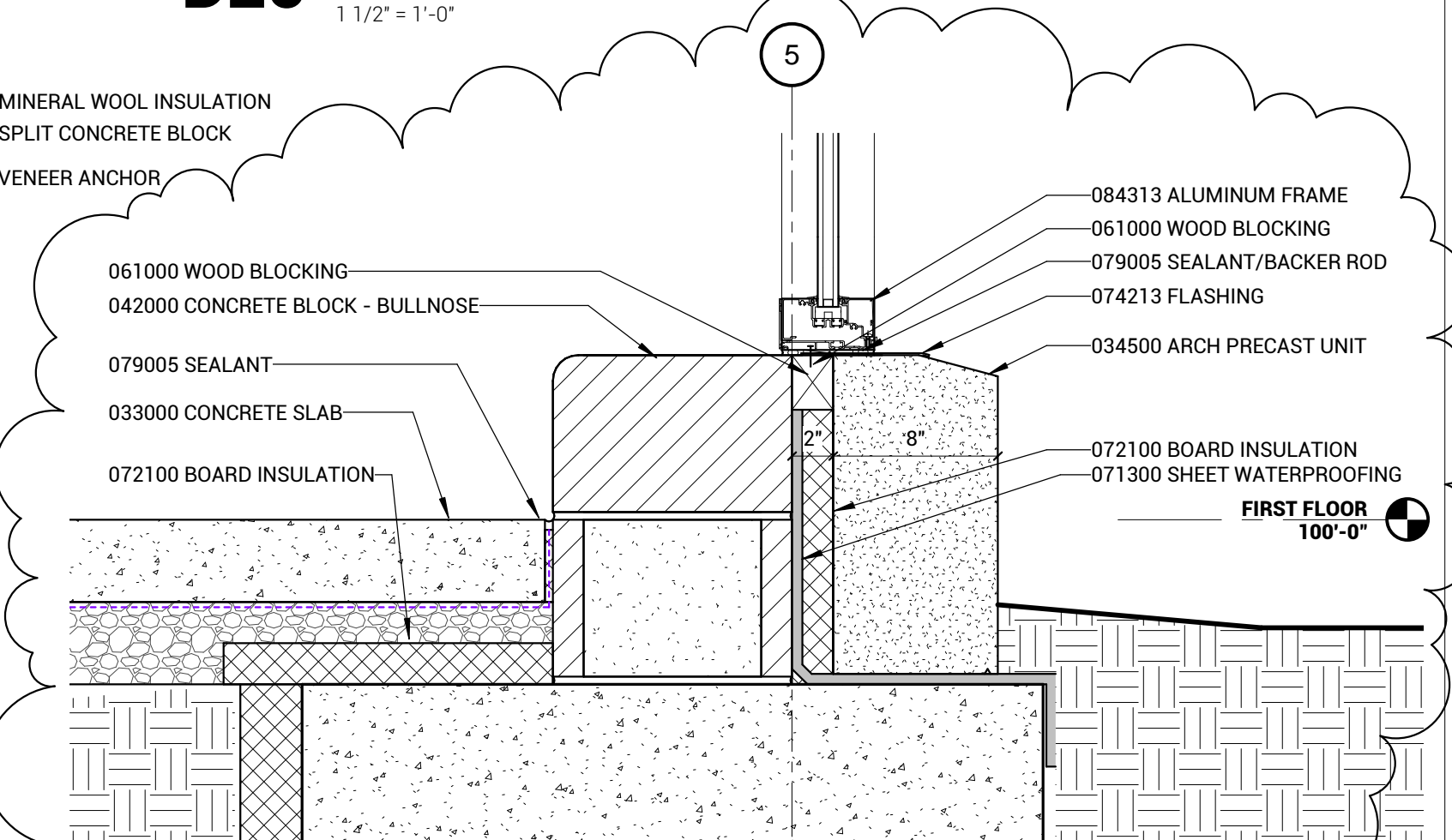

A20 SECTION DETAIL
 1 1/2" = 1'-0"

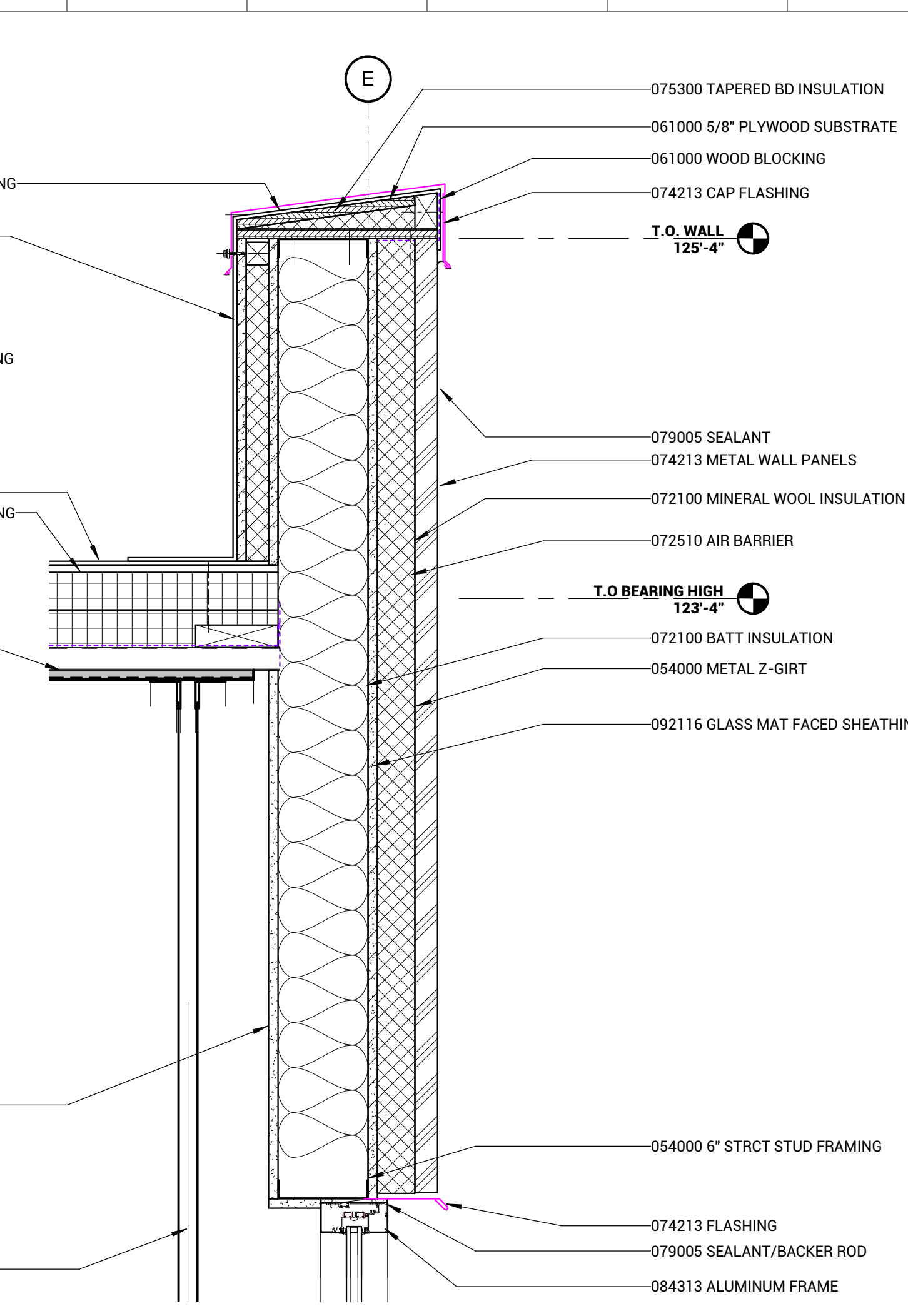

L9 SECTION DETAIL
 1 1/2" = 1'-0"

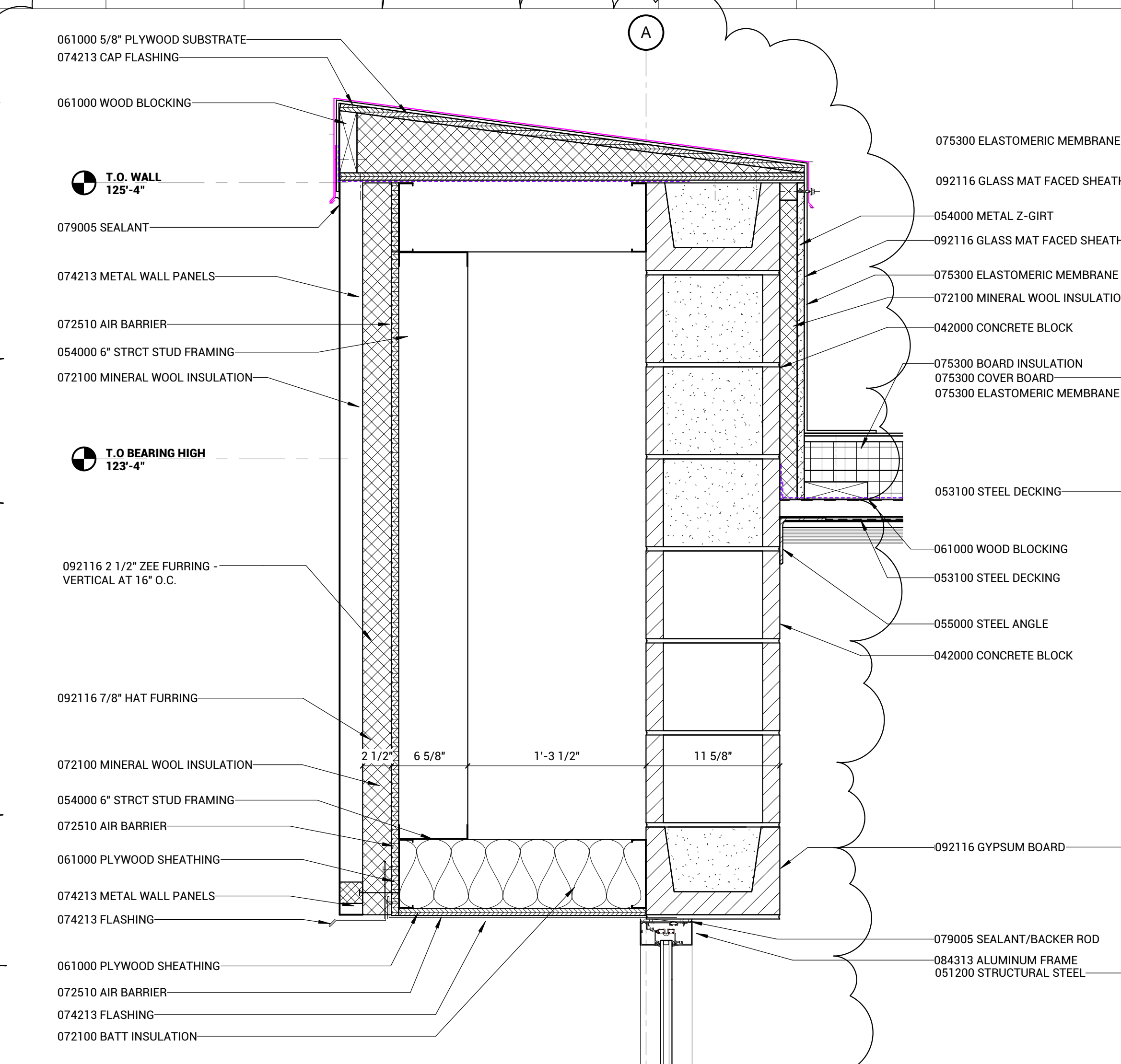

L1 SECTION DETAIL
 1 1/2" = 1'-0"

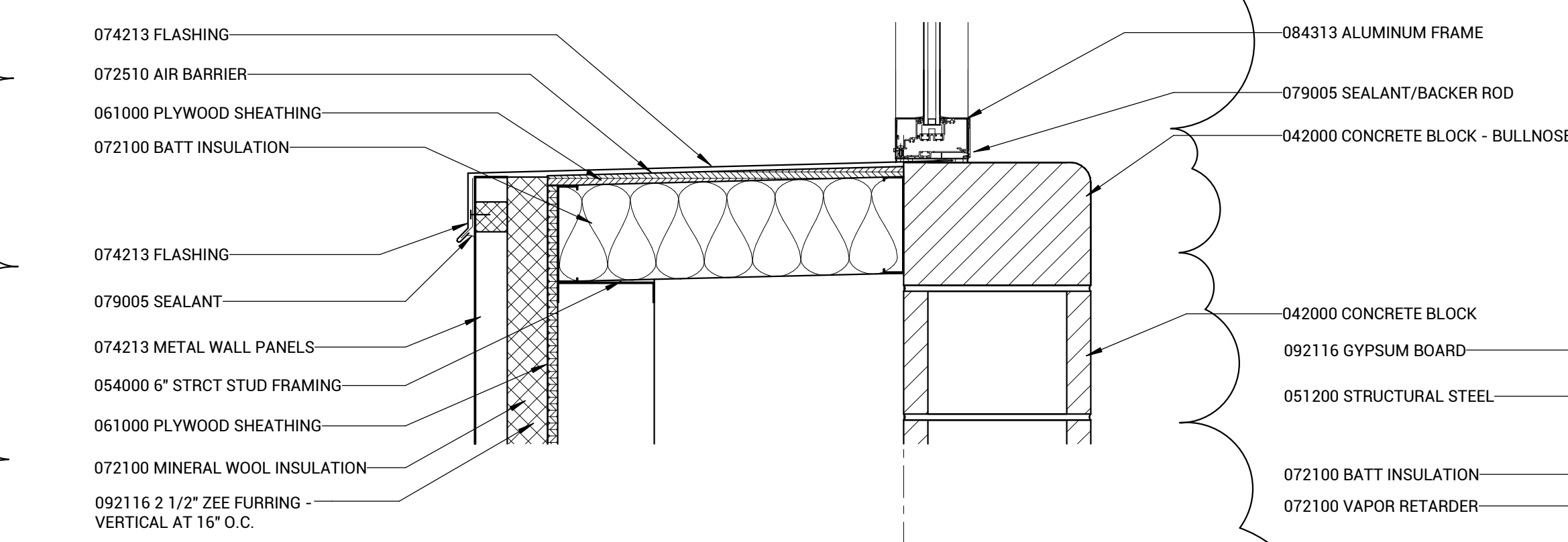

H1 SECTION DETAIL
 1 1/2" = 1'-0"

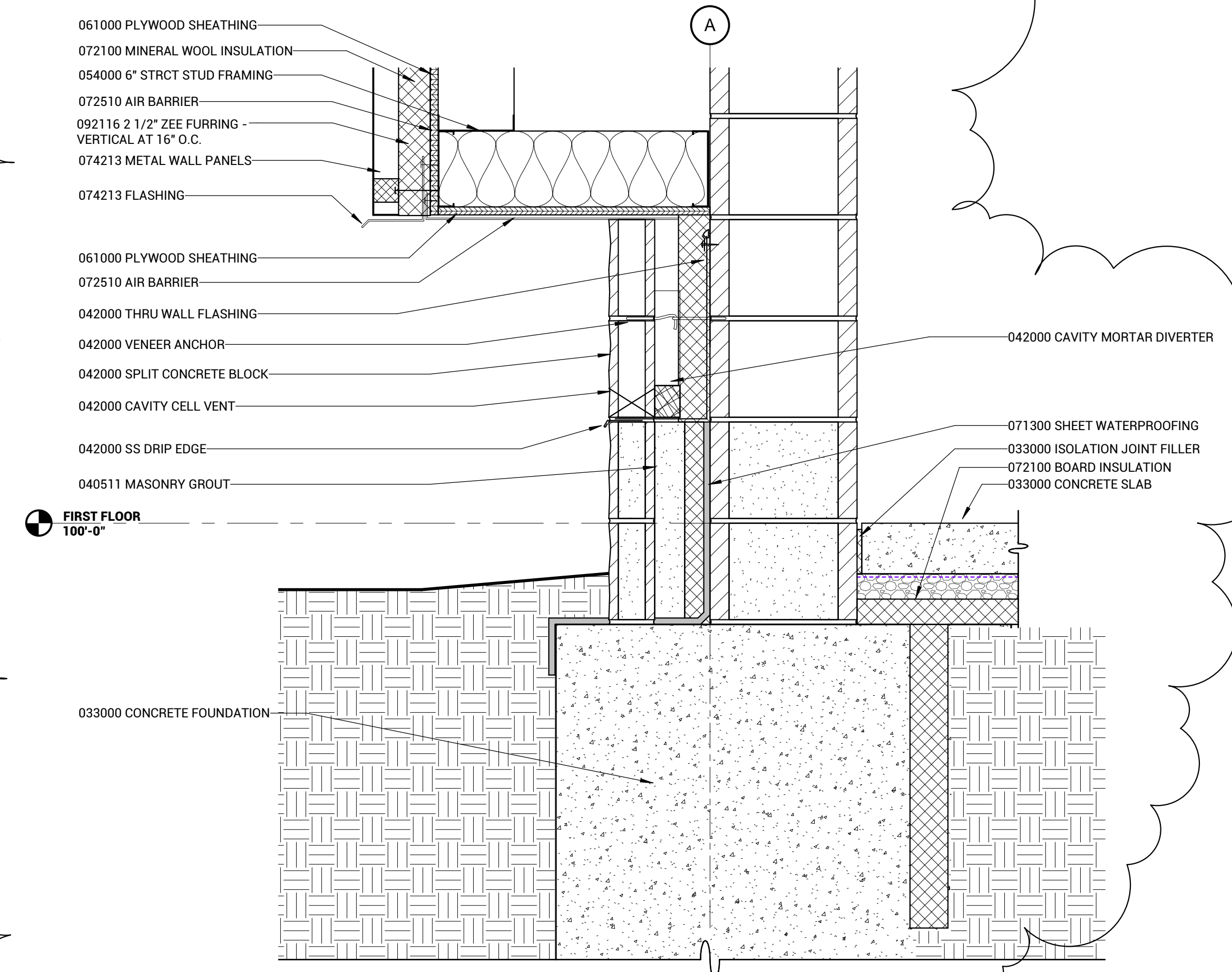

A1 SECTION DETAIL
 1 1/2" = 1'-0"



CROSS COUNTY SCHOOL - SHOP ADDITION

ADDENDUM #1 - ADD1.3

- ASI NO.:
- ADDENDUM NO.: 1
- CHANGE PROPOSAL REQUEST NO.:
- R.F.I REQUEST NO.:
- PROJECT: L14057
- PROJECT DATE: 08/11/14
- DATE ISSUED: 08/29/14

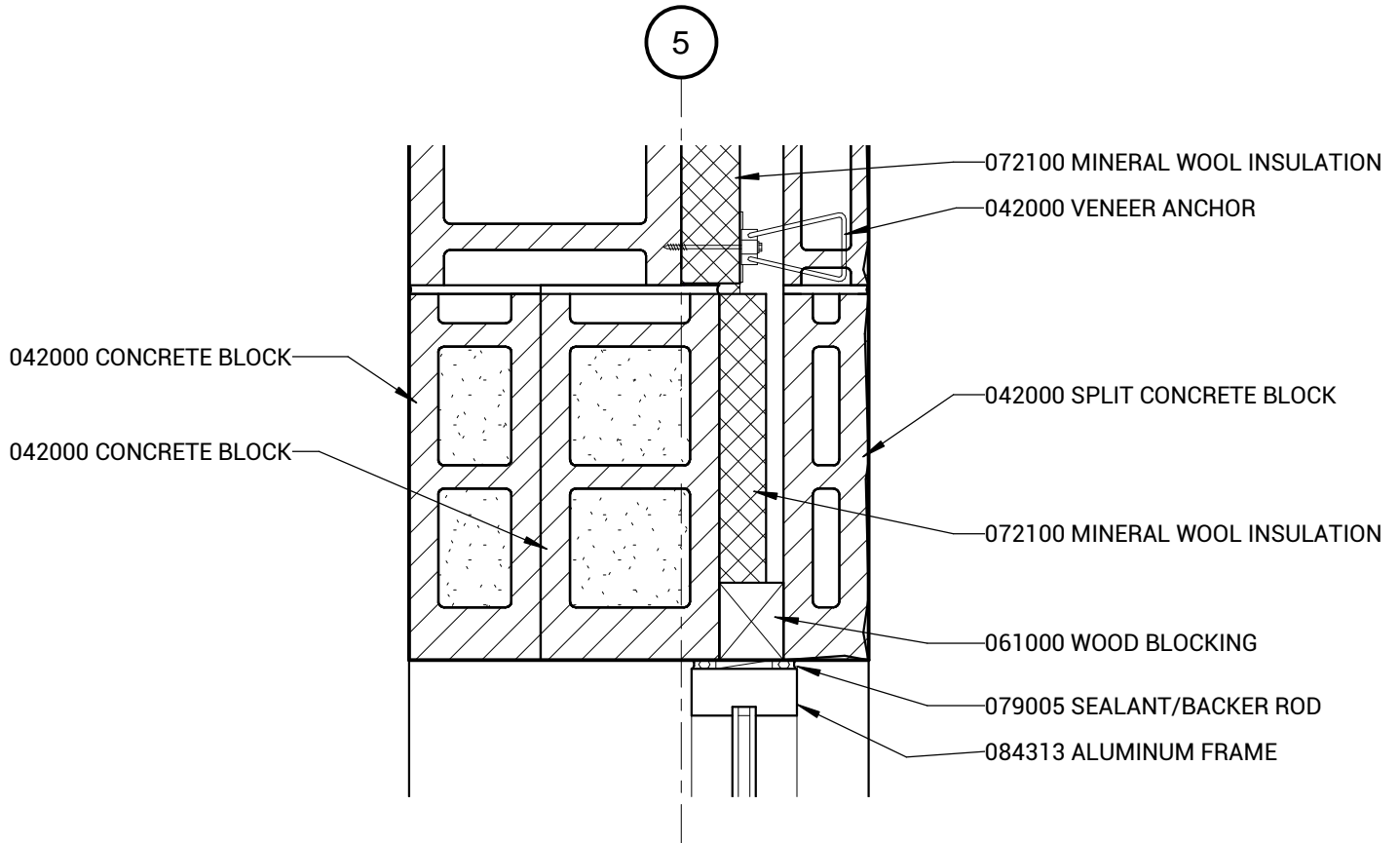

K20/A1.1 WINDOW JAMB DETAIL

1 1/2" = 1'-0"

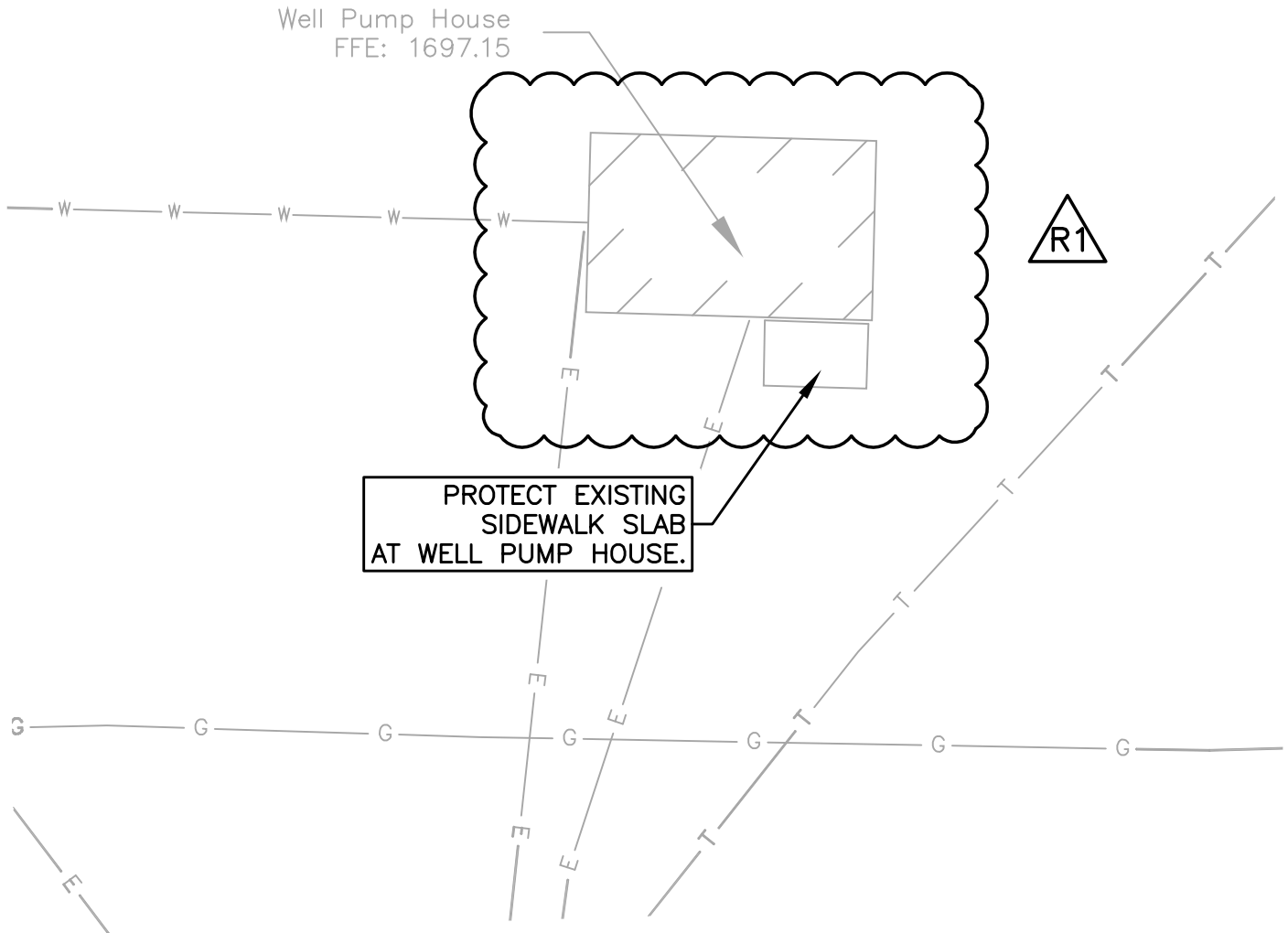

DEMOLITION PLAN

SCALE: 1" = 10'

REGA NO. 141135

ISSUED FOR:	DATE:	BY:
WELL PUMP HOUSE SIDEWALK SLAB IS NOT TO BE REMOVED, PROTECT.	08/28/14	SDB

REF. SHT# C1.1

CAUTION
PROTECT EXISTING
SANITARY LINE.

BENCHMARK #1
Sanitary Sewer Manhole
Rim: 1695.82
6" PVC FL: 1691.17
4" PVC FL: 1691.52



1" PREFORMED EXPANSION JOINT
WITH SEALANT ALONG BUILDING.

THICKENED EDGE
PAVEMENT.

2
C2.0

SCHOOL ADD.
F.F.E.=1697.21

CAUTION
PROTECT EXISTING
SANITARY LINE.

INSTALL WATER TIGHT
SEAL ON NEW STORM
INSIDE OF BUILDING.

CAUTION
PROTECT EXISTING GREASE
TRAP, ADJUST BUILDING
FOOTINGS AND PIPE
BOLLARDS AS NEEDED.
ADJUST MANHOLE LIDS
TO FINISH GRADE.

TAP 8" HDPE INTO EXISTING
12" PVC, FL(8")=1691.72,
ASSUMED, MATCH CENTERS.
BUILD TAP IN SHOP AREA
OF SCHOOL ADDITION.
FIELD VERIFY, INFORM
ENGINEER OF ANY CONFLICTS.

R1

Grease Trap
Rim: 1695.76

SS
8" HDPE
SS

SS 8" HDPE SS

TAP 8" HDPE INTO EXISTING
12" PVC, FL(8")=1691.90,
ASSUMED, MATCH CENTERS.
BUILD TAP IN SHOP AREA
OF SCHOOL ADDITION.
FIELD VERIFY, INFORM
ENGINEER OF ANY CONFLICTS.

7 8
C2.0 C2.0

ADJUST BOLLARDS
AWAY FROM GREASE
TANK.

Top of Concrete
Lid is 3' Below
Existing Grade

CAUTION
PROTECT EXIST.
STORM SEWER
LINE CROSSING.

1" PREFORMED EXPANSION JOINT
WITH SEALANT ALONG BUILDING.

1" PREFORMED EXPANSION JOINT
WITH SEALANT ALONG BUILDING.

LAYOUT/UTILITY PLAN

SCALE: 1" = 10'

INSTALL WATER TIGHT SEAL ON
ALL NEW STORM PIPES INSIDE
BUILDING. SEE MECHANICAL PLANS
FOR CONTINUATION OF ALL
UTILITIES (INCLUDING STORM)
INSIDE BUILDING.

R1

REGA NO. 141135

ISSUED FOR:	DATE:	BY:
ADDED UTILITY CONTINUATION NOTE. ADDED ADDITIONAL 8" HDPE FOR ROOF DRAINS TO TIE INTO EXISTING 12" STORM PIPE INSIDE BUILDING.	08/28/14	SDB

REF. SHT# C1.2





2014082

DATE ISSUED 08/27/2014

ADDENDUM # 1

ENGINEER Engineering Technologies, Inc.
825 M Street, Suite 200
Lincoln, NE 68508

PROJECT Cross County School Shop Addition

ETI PROJECT # 2014-082

The Architect issues this Addendum to all known bidders before receipt of proposals. Bidder shall acknowledge the receipt of this addendum on their proposal sheet and all information contained herein shall become a part of the contract documents.

ADDENDUM:

GENERAL ITEMS – MECHANICAL

- A. All new exposed piping is to be painted.

PRIOR APPROVAL – MECHANICAL

- 1. The following manufacturers have received prior approval for bidding purposes subject to shop drawing review:

Table with 2 columns: Equipment (Grilles, Registers, Diffusers; Flow Control valves; Unit Heaters; Spiral Duct; Wash Fountain) and Manufacturer (Price Industries; PRO Hydronic Specialties; Vulcan; Spiral Pipe of Texas; Willoughby)

DRAWINGS – MECHANICAL

- 1. Sheet M1.1 Mechanical Plans
A. General Notes:
i. Heat pump return piping running through existing Corridor 1197 may be run exposed through Art 1206 as an alternative route with piping painted.
2. Sheet M3.1 Mechanical Details
A. Add following down spout nozzle to plumbing fixture schedule.
i. DSN-1: Down Spout Nozzle: Smith model 1770 cast bronze with threaded outlet and wall flange.

PRIOR APPROVAL – ELECTRICAL

- 1. The following manufacturers have received prior approval for bidding purposes subject to shop drawing review:

Table with 2 columns: Equipment (Light Fixture Type 1; Light Fixture Type 6; Light Fixture Type 8; Lighting Control Devices) and Manufacturer (Metalux; Metalux; Metalux; Lutron)

DRAWINGS – ELECTRICAL

- 1. Sheet E2.1 First Floor Plan and Mezzanine Plan – Electrical and Demolition
A. Mount wall telephone outlet in Welding Area 104 at 54" A.F.F.

END OF ADDENDUM