

University of Nebraska-Kearney
UNK West Campus Utility Corridor Expansion

ADDENDUM #1 SUMMARY

June 16, 2014

The addendum is issued by the Engineer to all known bidders before receipt of proposals, for the purpose of explaining, interpreting, or modifying the original plans and specifications. When enumerated by the bidder on the bid form, the information or instructions given hereon will be equally binding upon all parties as if included in the original plans and specifications.

BIDDER MUST ENTER THE ADDENDUM NUMBER ON THEIR BID FORM

Addendum #1 – Item 1

The construction schedule for the UNK West Campus Utility Corridor Expansion shall be in compliance with the following dates:

CONSTRUCTION SCHEDULE:

Notice to Proceed: July 18th, 2014

Project Substantial Completion: On or before November 14th, 2014

Demolition and reconstruction of existing steam and steam condensate lines and connections to existing chilled water lines inside the existing West Center tunnel, as shown on Sheet M1.2 shall be substantially completed not later than August 18, 2014.

Addendum #1 – Item 2

PLAN SHEET REVISIONS:

Communication Conduit Plan, Sheet C7.1: DELETE plan notes referring to “bore depth”.
Communication conduits are not required to be bored and can be trenched per detail 3/C7.1.

Addendum #1 – Item 3

PLAN SHEET REVISIONS:

Electrical Details, Sheet E3.1, Ductbank Detail T1: **ADD** the following text, “Place sand layer in bottom of trench, 2” to 6” depth; depth shall be varied as required to provide level base for conduit supports and spacers.”

Addendum #1 – Item 4

PLAN SHEET REVISIONS:

Electrical Plans & Details, Sheet SE1.1: **CLARIFICATION** Panel E-1 is located in the existing tunnel, in the lower level of the West Center Building. Panel E-1 is located on a wall approximately 100’ south of the proposed utility trench connection location.

Addendum #1 – Item 5

PLAN SHEET REVISIONS:

REFER to Chilled Water Supply & Return Plan, Sheet C6.1: Concrete thrust collars shall be added to chilled water supply and return lines at Sta. 0+10.00 and Sta. 8+25.00. Thrust collars shall be installed as shown on the attached detail C6.1a.

Addendum #1 – Item 6
PLAN SHEET REVISIONS:

REFER to Mechanical Tunnel Plans, New Tunnel Plan, Sheet M1.2:

- A. Add pipe anchoring to the existing 4” steam and 2” condensate lines as shown on attached Construction Clarification M1.2a, dated 6/16/14. Anchor pipes as shown on the attached Construction Clarification M3.1a.
- B. Add pipe anchoring to the new pipe tees exiting the tunnel, and add expansion loops as shown on attached Construction Clarification M1.2b, dated 6/16/14. Anchor pipes as shown on the attached Construction Clarification M3.1a.
- C. Add the following Keynote 13: “Install Expansion Loop EL-1 in new 6” HPS piping. Provide pipe guides within 36” of expansion loop connections. Support the 90 degree elbow from the ceiling according to manufacturer’s recommendations to provide a horizontal installation. Provide 3” pipe insulation on expansion loop.”
- D. Add the following Keynote 14: “Install Expansion Loop EL-2 in new 3” PC piping. Provide pipe guides within 36” of expansion loop connections. Support the 90 degree elbow from the ceiling according to manufacturer’s recommendations to provide a horizontal installation. Provide 2” insulation on expansion loop.”
- E. Add the following Keynote 15: “Anchor the existing 4” HPS pipe in the approximate location shown. Provide anchoring from the ceiling of the existing tunnel capable of resisting 6300 lbs. of force.”
- F. Add the following Keynote 16: “Anchor the existing 2” PC pipe in the approximate location shown. Provide anchoring from the ceiling of the existing tunnel capable of resisting 2500 lbs. of force.”
- G. Delete Keynote 6 and replace with the following: “Extend 6” HPS up through existing tunnel ceiling into new trench. Refer to sheet M1.3 for continuation. Anchor the pipe tee to the existing tunnel ceiling to resist a force of 280 lbs.”
- H. Delete Keynote 7 and replace with the following: “Extend 3” PC up through existing tunnel ceiling into new trench. Refer to sheet M1.3 for continuation. Anchor the pipe tee to the existing tunnel ceiling to resist a force of 115 lbs.”

Addendum #1 – Item 7
PLAN SHEET REVISIONS:

Refer to the Drawings, Sheet M4.1 – Mechanical Schedules.

- A. Refer to Expansion Joint Schedule; revise the Delta T for Expansion Joint EJ-9 to “353°F”.
- B. Add the following Expansion Loop Schedule: “Expansion Loop Type 1 (EL-1): Metraflex V-loop VLW60600 or approved equal, 6” diameter, welded connections, schedule 40 fittings, stainless steel single braided flexible hose, +/- 3.0 inches axial movement. Install in horizontal plane.”
- C. Add the following Expansion Loop Schedule: “Expansion Loop Type 1 (EL-2): Metraflex V-loop VLW60300 or approved equal, 3” diameter, welded connections, schedule 80 fittings, stainless steel double braided flexible hose, +/- 3.0 inches axial movement. Install in horizontal plan.”

Addendum #1 – Item 8
SPECIFICATION REVISIONS:

SECTION 00 41 13 – BID PROPOSAL FORM

REPLACE the section in its entirety with the revised section attached to this document

Addendum #1 – Item 9
SPECIFICATION REVISIONS:

SECTION 01 23 00 – ALTERNATES

ADD the following paragraph:

Alternate No. 3:

Shall include the installation of a leak detection system in the direct bury steam and condensate piping between Vaults #2 and #3 and other associated work which as indicated in Addendum #1, Item 10 to specification section 23 63 13.

Addendum #1 – Item 10
SPECIFICATION REVISIONS:

SECTION 23 05 23 – GENERAL DUTY VALVES FOR HVAC PIPING: Refer to section 2.6 – IRON GATE VALVES, **DELETE** Paragraph B and **REPLACE** with the following:

- B. Non-rising-Stem, Resilient-Seated Gate Valves, (for Chilled Water applications only)
 - 1. Description: 3-Inch NPS and larger: AWWA C509., gray- or ductile-iron body and bonnet; with bronze or gray- or ductile-iron gate, resilient seats, bronze stem, and stem nut. Include 200-psig minimum working-pressure design, interior coating according to AWWA CSSO, and mechanical joint ends and direction of opening left.
 - a. Gate Valves shall be wrapped with a polyethylene wrap and taped in accordance with Method C of AWWA C105 after installation. The wrap shall

completely cover the valve, and operator, taped around the ends to form a good seal.

Addendum #1 – Item 11

SPECIFICATION REVISIONS:

SECTION 23 61 13 – UNDERGROUND HYDRONIC ENERGY DISTRIBUTION:

- a. HDPE piping shall be steel pipe size (IPS).
- b. Refer to section 1.2 – PERFORMANCE REQUIREMENTS, Paragraph A.1, **REVISE** the pressure rating of Chilled Water Piping to “200 psig”.
- c. Refer to section 3.2 – PIPING APPLICATION, Paragraph A, subparagraph 1, **DELETE** paragraph “a.” and **REPLACE** with the following: “a. DR 11 (200 psi WPR) HDPE pipe and fittings, with fused joints.”
- d. Refer to section 3.4 – FUSION, Paragraph D, **ADD** the following: “Connections to direct bury gate valves and bends shall be made with the use of mechanical joints and mechanical joint adapters.

Addendum #1 – Item 12

SPECIFICATION REVISIONS:

SECTION 23 63 13 – UNDERGROUND STEAM AND CONDENSATE DISTRIBUTION PIPING:

- A. Refer to section 3.2 – PIPING APPLICATION, Paragraph A, Subparagraph 2.a, **REVISE** minimum insulation thickness to 1.5”.
- B. Refer to section 3.2 – PIPING APPLICATION, Paragraph A, **ADD** the following Paragraph 5: “
 - i. Leak Detection System: As Alternate No 3, the piping system between Vault #2 and Vault #3 shall be leak detection ready by means of manufacturing into the system a cable through each piece of pre-insulated pipe and fittings which can identify the location of moisture buildup. The piping system manufacture shall install the cable in a manner that has the cable embedded in the outer polyurethane foam insulation and not touching the steel conduit. Provide a panel with audible alarm within Vault #2 which will provide for continuous leak detection monitoring and periodic manual testing. The panel shall be capable of passing system and cable status data to a building management system.”
- C. Refer to Section 3.2 – PIPING APPLICATION, Paragraph B, Subparagraph 2.a, **REVISE** minimum insulation thickness to 1”.
- D. Refer to Section 3.2 – PIPING APPLICATION, Paragraph B, Subparagraph 2.b, **REVISE** minimum insulation thickness to 1.25”.
- E. Refer to section 3.2 – PIPING APPLICATION, Paragraph B, **ADD** the following Paragraph 5: “

5. Leak Detection System: As Alternate No 3, the piping system between Vault # 2 and Vault #3 shall be leak detection ready by means of manufacturing into the system a cable through each piece of pre-insulated pipe and fittings which can identify the location of moisture buildup. The piping system manufacture shall install the cable in a manner that has the cable embedded in the outer polyurethane foam insulation and not touching the steel conduit. Provide a panel with audible alarm within Vault #2 which will provide for continuous leak detection monitoring and periodic manual testing. The panel shall be capable of passing system and cable status data to a building management system.”

END OF ADDENDUM #1

SECTION 00 41 13 - BID PROPOSAL FORM

BID PROPOSAL

TO: THE BOARD OF REGENTS OF THE UNIVERSITY OF NEBRASKA
c/o University of Nebraska-Kearney
General Services Building
Department of Facilities
2507 19th Avenue
Kearney, NE 68849-4310

BID PROPOSAL FOR: «Type_of_Contractor»

PROJECT: K800P002, West Campus Utility Corridor Expansion

COMPLETE THE FOLLOWING INFORMATION – BIDDERS NAME AND TYPE OF BUSINESS:

This Bid is offered by _____, hereinafter referred to as the Bidder,
a corporation organized and existing under the laws of the State of _____
a partnership doing business as _____
an individual doing business as _____

In response to the Bidding Requirements for the construction of the project identified above by name, quotation number, and project number, the Bidder hereby makes the following representations:

Bidder has received the drawings and specifications for the project prepared by Olsson Associates

Bidder has examined the Bidding Documents, visited the site, and otherwise familiarized itself with the local conditions affecting the construction of the project.

COMPLETE THE FOLLOWING INFORMATION – BASE BID:

Bidder agrees to furnish all labor, materials, tools, equipment, services, transportation, and supervision required to complete the work indicated in the Bidding Documents within the time set forth herein for the lump sum Base Bid amount of _____ dollars(\$_____).

COMPLETE THE FOLLOWING INFORMATION – ALTERNATE PROPOSALS:

The Base Bid amount given above may be increased or decreased by the acceptance of any of the Alternate Proposals listed below. The full and complete description of the work to be added to or deleted from the scope of the project by each of the Alternate Proposals is that found in Division 01, Section 01 23 00 - Alternates.

ALTERNATE NO. 1: Pedestrian Lighting Fixture Head Replacement

ADD the sum of _____ dollars (\$_____)

ALTERNATE NO. 2: Installation of Irrigation Well System

ADD the sum of _____ dollars (\$_____)

ALTERNATE NO. 3: Leak Detection System for Direct Buried Steam/Condensate Piping

ADD the sum of _____ dollars (\$_____)

PROVIDE THE FOLLOWING INFORMATION – BID SECURITY:

Included with this Proposal is Bid Security of the type and in the amount required by the Bidding Instructions.

COMPLETE THE FOLLOWING INFORMATION – NUMBER OF ADDENDA RECEIVED:

Bidder has received Addenda Nos. _____, and has included their provisions in this Bid.

COMPLETE THE FOLLOWING INFORMATION – # CALENDAR DAYS TO COMPLETE THE WORK:

In submitting this Bid, Bidder agrees to the following:

1. To hold this Bid open for 60 days following the bid date.
2. To enter into and execute the "University of Nebraska Standard Form Construction Agreement" based upon this Bid, if accepted by Owner.
3. To perform all work required by the Contract Documents.
4. To substantially complete the work not later than _____ calendar days from the start of construction given in the Notice to Proceed. (Bidder to enter number of days.) Time is of the essence and may be a factor in the award of this Contract.
5. That this Bid has been arrived at without collusion with other Bidders and without any effort or activity which might prevent the University of Nebraska from receiving the lowest possible competitive Bid.
6. To comply with Nebraska Fair Employment Practice Act, understanding that a breach of this provision will be regarded as a material breach of contract.

COMPLETE THE FOLLOWING INFORMATION – SIGNATURE AND CONTACT INFORMATION:

Address:

Signature:

Printed Name:

Tele. No.:

Title:

Fax. No.:

Dated this _____ day of _____, 20_____

Email Address: _____

USER: trajewski

DWG: F:\Projects\013-1741_MECH\1-UNK West Campus Utility Corridor Expansion\Constructs\Mechanical\MMN1A.dwg
DATE: Jun 16, 2014 11:03am XREFS: Xref Title Block 131741_XBASE Xref - 8.5x11V

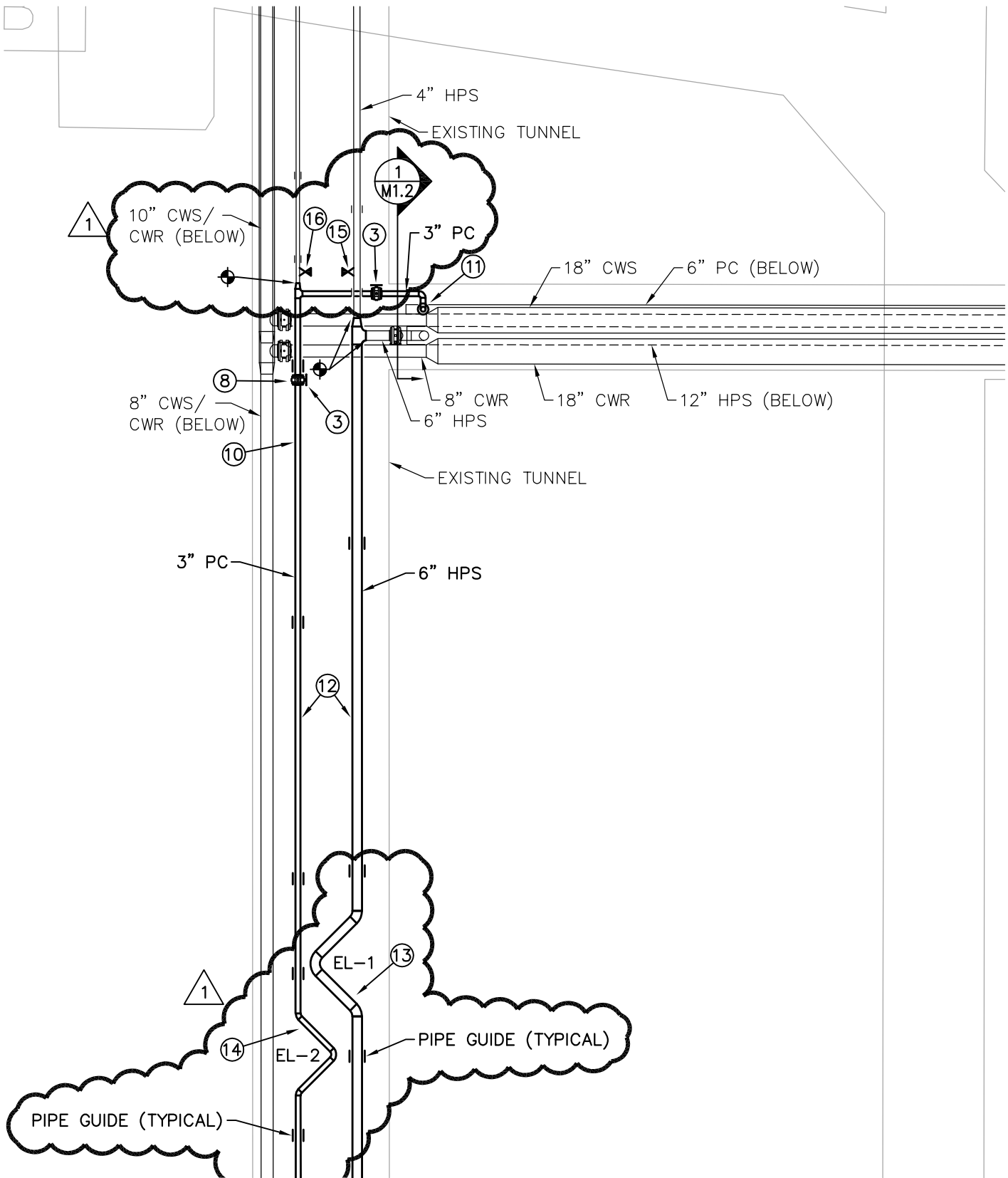

NEW TUNNEL PLAN

SCALE: 1/8" = 1'-0"



1111 Lincoln Mall, Suite 111
P.O. Box 84608
Lincoln, NE 68501-4608

TEL 402.474.6311
FAX 402.474.5160
www.olssonassociates.com

(Sheet Number)

M1.2

(Project Number)
013-1741
(Drawing Number)

(Date)
05-30-14

NEW TUNNEL PLANS
WEST CAMPUS UTILITY CORRIDOR EXPANSION
UNIVERSITY OF NEBRASKA - KEARNEY



Attachment No. M1.2a
to Addendum No. 1
Dated: June 16, 2014

USER: trajewski

DWG: F:\Projects\013-1741_MECH\1-UNK West Campus Utility Corridor Expansion\Constructs\Mechanical\MMN1A.dwg
DATE: Jun 16, 2014 11:03am XREFS: Xref Title Block 131741_XBASE Xref - 8.5x11V

XREFS: Xref Title Block 131741_XBASE

DATE: Jun 16, 2014 11:03am

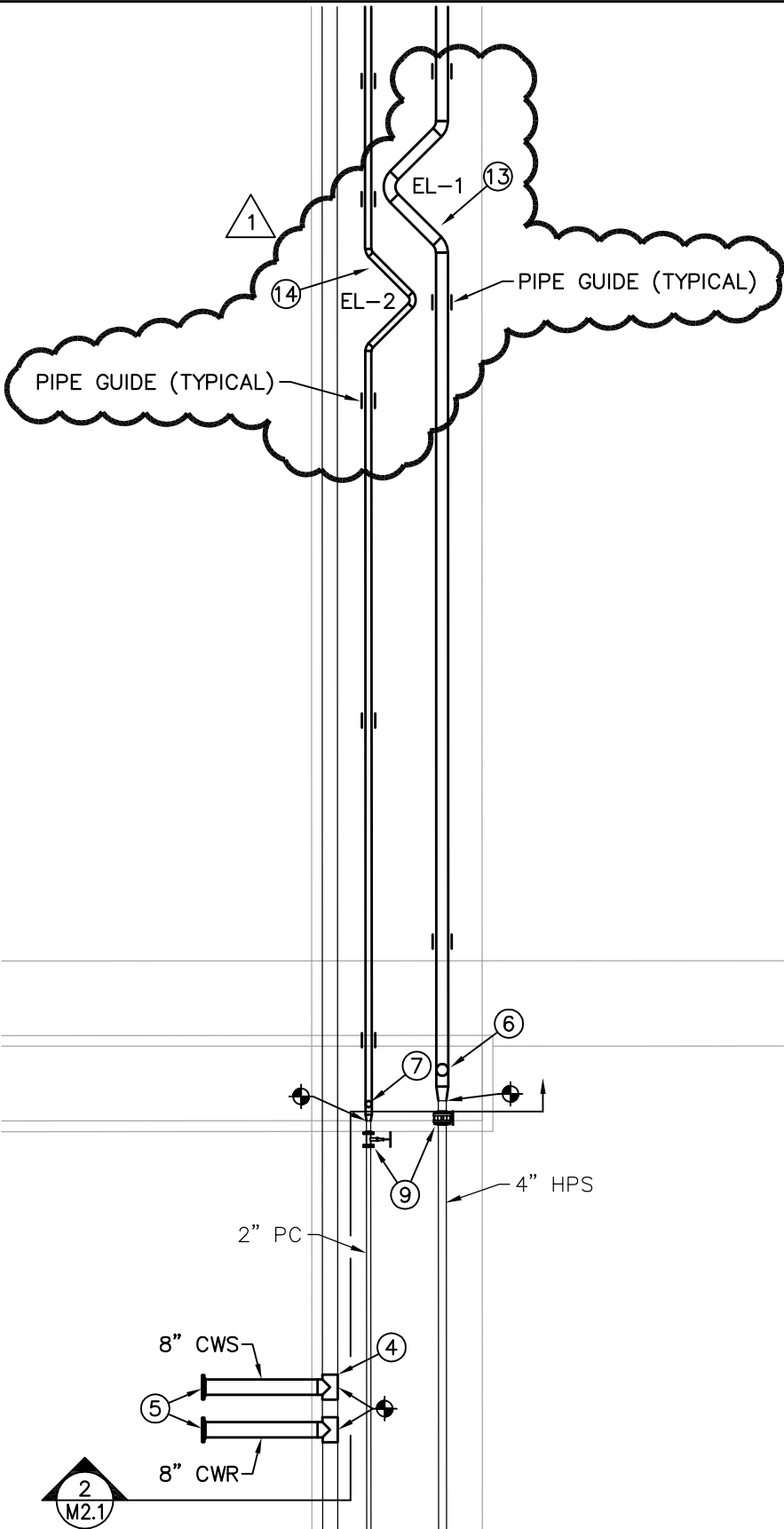

2
M2.1



NEW TUNNEL PLAN

SCALE: 1/8"=1'-0"



1111 Lincoln Mall, Suite 111
P.O. Box 84608
Lincoln, NE 68501-4608

TEL 402.474.6311
FAX 402.474.5160
www.olssonassociates.com

(Sheet Number)

M1.2

(Project Number)
013-1741
(Drawing Number)

(Date)
05-30-14

NEW TUNNEL PLANS
WEST CAMPUS UTILITY CORRIDOR EXPANSION
UNIVERSITY OF NEBRASKA - KEARNEY



Attachment No. M1.2b
to Addendum No. 1
Dated: June 16, 2014

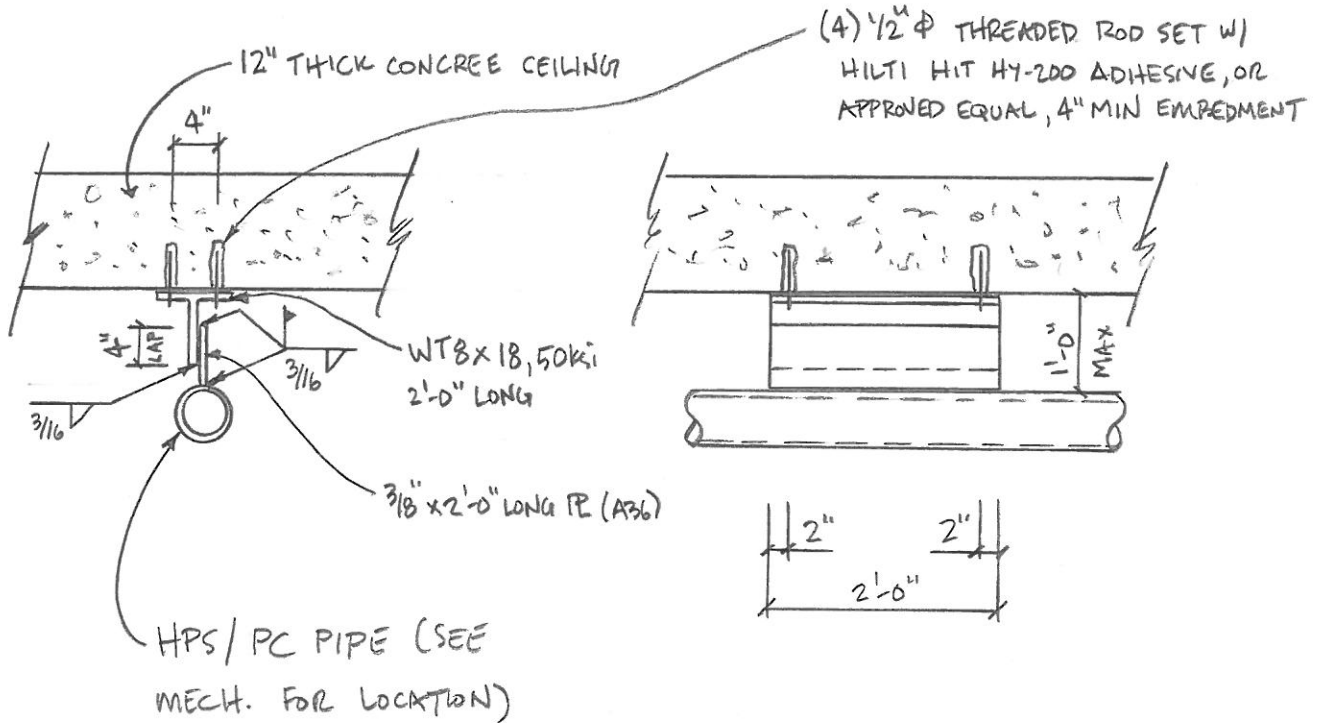

Attachment No. M3.1a to
Addendum No. 1
June 16, 2014

project: UNK WEST CAMPUS UTILITY CORRIDOR EXPANSION

subject ADDENDUM #1

drawn by: CRS

date: 6/16/14 project no.: 013-1741

sheet 1 of 1

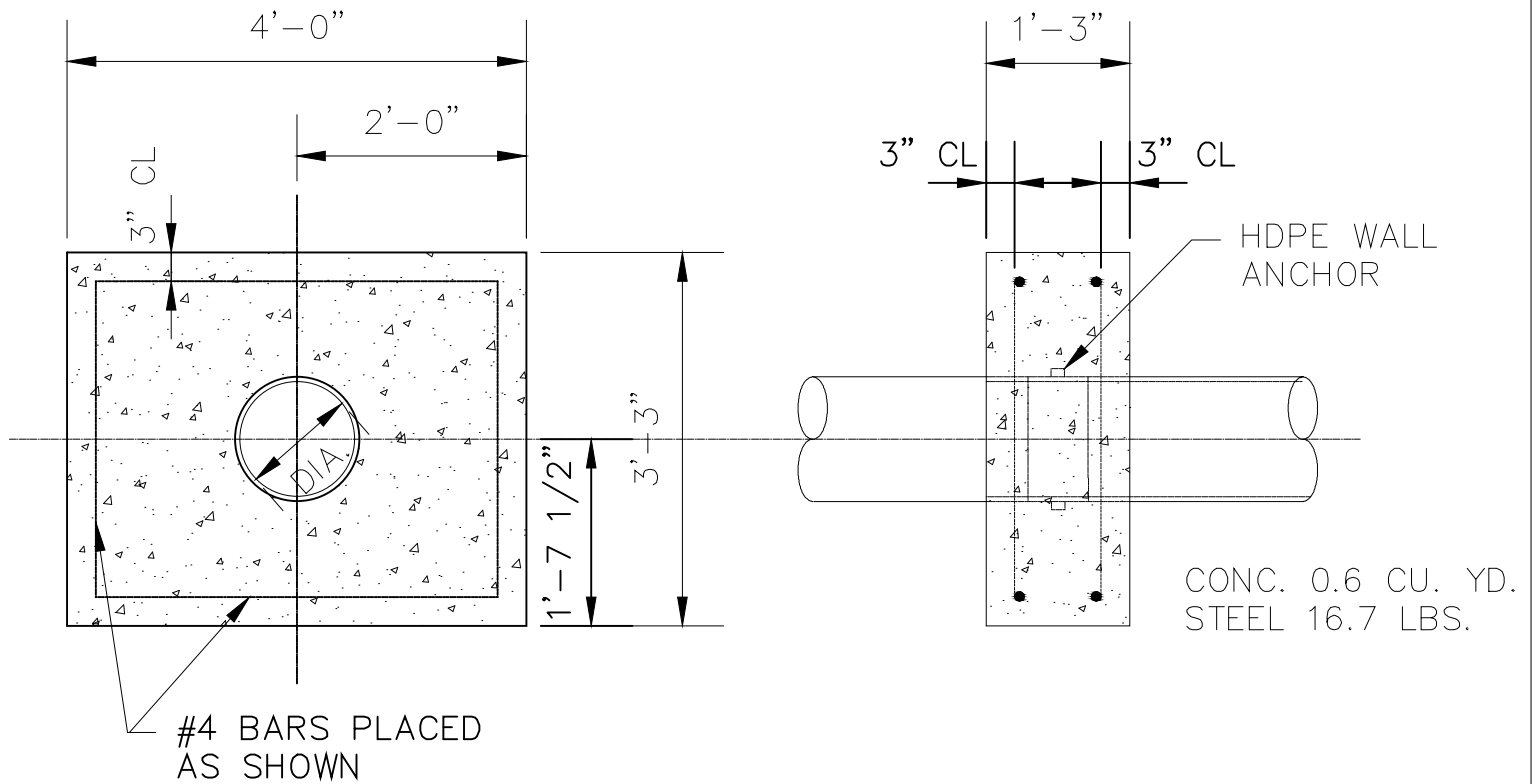

THRUST COLLAR DETAIL
12" OR SMALLER WATER MAINS

Attachment No. C6.1a
to Addendum No. 1
June 16, 2014