

## **ADDENDUM 1 (AD-1)**

Date: May 19, 2014

Owner: UNMC  
Project: Campus Site Utility Improvements  
UNMC Quotation Number: 3118-P  
UNMC Project Number: P-14037

Architect: HDR Architecture, Inc.

Andrew Yosten

Address: 8404 Indian Hills Drive; Omaha, NE 68114-4098

### **NOTICE:**

This Addendum is issued to known individuals, firms or corporations holding Bidding Documents and Contract Documents for above listed project.

This Addendum is hereby made a portion of Bidding Documents and Contract Documents. Bidders are required to acknowledge receipt of Addendum in appropriate space on Bid Form.

### **INDEX:**

1. Changes to Civil Drawings.
2. Changes to Structural Drawings.
3. Changes to Mechanical Drawings.
4. Changes to Electrical Drawings.
5. Changes to Project Manual.
6. Attachments:
  - a. Specification Changes.
  - b. Drawings.

## CHANGES TO CIVIL DRAWINGS

- A. Sheet C-101:
  - 1. Revised Note 1.

## **CHANGES TO STRUCTURAL DRAWINGS**

- A. Sheet S-501:
  - 1. Revise detail D5 per reissued sheet.
  - 2. Revise detail C5 per reissued sheet.
  - 3. Add detail C4 per reissued sheet.

## CHANGES TO MECHANICAL DRAWINGS

- A. Sheet M-101: Sheet Reissued
  - 1. See Landscaping Notes for site restoration.
- B. Sheet M-102: Sheet Reissued
  - 1. Revise sheet notes:
    - a. Work (trenching of piping) across Emile Street shall take place between 9PM – 6AM while maintaining traffic flow.
      - 1) Alternate No. 2: Allows for boring under Emile Street during normal working hours.
    - b. Contractor shall have utilities located along entire length of pipe installation.
    - c. See Landscaping Notes for site restoration.
- C. Sheet M-103: Sheet Reissued
  - 1. See Landscaping Notes for site restoration.
- D. Sheet MP-101: Sheet Reissued
  - 1. Provide flexible hose type expansion joints in lieu of piping U-loops as indicated.
  - 2. Revise structural piping supports as indicated. Piping supports to be installed on housekeeping pads.
- E. Sheet MP-102: Sheet Reissued
  - 1. Relocate existing bollards to protect new piping.
- F. Sheet MP-LL2B: Sheet Reissued
  - 1. Clarification: There is no new work in Area B.
  - 2. Revise general notes.
- G. Sheet MP-LL-2C: Sheet Reissued
  - 1. Revise general notes.
- H. Sheet MP-10G: Sheet Reissued
  - 1. Provide full diameter cross connection between supply and return piping to allow for flushing of system by Central Utility Plant Improvements contractor.
  - 2. Revise general notes.

## CHANGES TO ELECTRICAL DRAWINGS

- A. Sheet E-101 (Sheet Reissued):
  - 1. Rename and Re-Number Utility Tunnel Plan
  - 2. Add receptacle relocation work to DRC-I Utility Tunnel
  - 3. Add Detail#3 – Receptacle Relocation Detail

## CHANGES TO PROJECT MANUAL

### 1.1 GENERAL NOTE

- A. If paragraph has been changed by this addendum, entire page has been reprinted. "AD" helps indicate line changed. Contractor is responsible for review of entire page to determine all changes made within paragraph.
- B. The following Sections have changed:
  - 1. Section 00 11 16: Revised.
    - a. Revised Bid Date.
    - b. Issued Pre-Bid Meeting Sign-In Sheet, "For Information Only."
  - 2. Section 01 11 00: Revised.
    - a. Work in Lot 50 shall be completed by December 1, 2014.
  - 3. Section 01 23 00: Revised.
    - a. Alternate No. 2: Boring pipes under Emile Street during normal working hours.
  - 4. Section 01 31 00: Revised.
    - a. Provide coordination drawings for all work indicated on contract documents.
  - 5. Section 20 05 19: Reissued.
    - a. Deleted items that are not applicable such as pressure gauges, thermometers, strainers, ect.
    - b. Revised expansion joints to flexible hose type.
  - 6. Section 20 05 23: Reissued.
    - a. Delete valves that are not applicable.
  - 7. Section 20 05 53: Reissued.
    - a. Delete sections that are not applicable.
  - 8. Section 20 10 10: Revised.
    - a. Delete sections that are not applicable.
  - 9. Section 20 11 00: Reissued.
    - a. Revised grooved piping installation requirements to include 30 year warranty.
    - b. Deleted sections that are not applicable.
  - 10. Section 23 21 13: Reissued.
    - a. Deleted sections that are not applicable.
    - b. Revised cleaning of system section: Flushing of system to be completed by Central Utility Plant Improvements contractor.

**SECTION 00 11 16 - INVITATION TO BIDDERS (Revised AD-1)**

**1.0 INVITATION**

- A. The Board of Regents of the University of Nebraska invites Bids for a Single Prime Contract for the UNMC Campus Site Utilities Distribution – Hot Water Mechanical Package The University of Nebraska Medical Center, Omaha, Nebraska (UNMC). The purpose of this project is route new heating hot water piping from the Central Utility Plant to the Fred and Pamela Buffett Cancer Center.

**2.0 QUOTATION NUMBER: 3118-P**

**3.0 PROJECT NUMBER: P-14037**

**4.0 PROJECT NAME: UNMC Campus Site Utilities Distribution – Hot Water Mechanical Package**

**5.0 COMPLETION**

- A. Substantial Completion date of June 30, 2015.
- B. There is not a Liquidated Damages clause.

**6.0 QUALIFICATION REQUIREMENTS**

- A. Bidder shall submit or have, on file with the Owner, a current Contractor's Qualification Statement to submit a Bid for this Project. See Section 00 21 13 - Instructions to Bidders for requirements.

**7.0 MANDATORY PRE-BID MEETING**

- A. All Bidders are required to attend and other interested parties are invited to attend a Pre-Bid meeting for distribution of information and tour of Project Site.
  - 1. TIME: May 15, 2014, 9:30 am local rime.
  - 2. PLACE: University of Nebraska Medical Center  
Facilities Management and Planning  
4230 Building Room 2007  
Omaha, Nebraska
  - 3. Parking: Lot 25, SE Corner, 42<sup>nd</sup> and Leavenworth

**8.0 BID RECEIVING AND OPENING: Sealed Bid Proposals as follows:**

***AD-1: Section 00 11 16; 05/19/2014: Revised paragraph 8.0, A.***

**A. RECEIVING TIME: May 28, 2014, 2:00 pm Local Time.**

**B. RECEIVING PLACE: Purchasing Department, by one of following methods:**

- 1. Hand-Carry Delivery: Facilities Management and Planning, Room 2019  
4230 Leavenworth  
Omaha, Nebraska
- 2. Mailing Address: Facilities Management and Planning  
University of Nebraska Medical Center

Project: Campus Site Utility Improvements

Project No.: P-14037

Meeting Subject: Pre-Bid Meeting

Date: 05/15/2014 @ 9:30 a.m.

<u>NAME/ORGANIZATION</u>	<u>PHONE NO.</u>	<u>FAX NO.</u>	<u>E-MAIL</u>
DAN MICHALAK UNMC FM&P, A/E	402-981-7917	402-559-9918	dmichalak@unmc.edu
Dick Hanson Grunwald Mechanical	402-342-1911	402-342-5862	rchanson@grunwald1.com
ERIC CROSS MAINELLI MECHANICAL	402-457-5501	402-457-3511	eric.cross@mainelli-mechanical.com
Nick Combs UNMC A+E	402-981-7367	402-559-8282	NCOMBS@UNMC.BDU
Neal Buxcel UNMC FM+P	402-871-0313		neal.buxcel@unmc.edu
MIKE FABER UNMC FM+P	402-559-4503		mfaber@unmc
ANDREW ROCHE HDR	(402)399-4884		aroche@hdrinc.com
Brian Eyr/ General Excavating	(402)467-1607	(402)467-2081	beyr@generalexavating.com
Darren Dageforde unmc	(402)981-7862	559-8282	ddagefor@unmc.edu
JOHN McNEIL	(402)679-1373		JOHN.McNEIL@GRUNWALD1.COM

Project: Campus Site Utility Improvements

Project No.: P-14037

Meeting Subject: Pre-Bid Meeting

Date: 05/15/2014 @ 9:30 a.m.

<u>NAME/ORGANIZATION</u>	<u>PHONE NO.</u>	<u>FAX NO.</u>	<u>E-MAIL</u>
WALDINGER KURT SANDER	402.616-4221	402.339-5824	KURT.SANDER@WALDINGER.COM
Chuck Cole CONTROLTEMP, INC.	402-346-3422	402-346-3423	CCole@ControlTempInc.COM
Control Temp Andrew Griffith	402.346.3422	402-346-3423	agriffith@controltempinc.com
JORGE Garcia Ayars & Ayars	402 430 2286		JGARCIA@AYARSAYARS.COM
BRIAN COLPITS SCOTT ENTERPRISES	402 571 2364		bcolpitts@scottent.com
Pittlor + Son Frank Kankowsky	402-981-8427		
Pittlor + Son Jim Armstrong	402-981-8428	402-331-9268	Jim@Pittlor.com
PRairie CONSTRUCTION COMPANY MATT SELTMAN	402-330-8522	402-330-8544	mattprairie-construction.com
UNMC Purchasing	9-4037		KT Nelson

**SECTION 01 11 00 – SUMMARY OF WORK (Revised AD-1)**

**PART 1 - GENERAL**

1.1 RELATED DOCUMENTS

- A. Drawings and general provisions of the Contract, including General Conditions and other Division 1 Specification Sections, apply to this Section.

1.2 WORK COVERED BY CONTRACT DOCUMENTS

- A. The Work consists of but is not limited to: The purpose of this project is route new heating hot water piping from the Central Utility Plant to the Fred and Pamela Buffett Cancer Center. The heating hot water piping extends from the west side of the Central Utilities Plant, through the lower level of the existing Lot 50 parking garage, across Emilee Street to the basement of the existing Durham Research Center II, and ultimately through the existing utilities underground tunnel to the new Fred and Pamela Buffett Cancer Center.

***AD-1: Section 01 11 00; 05/19/2014: Revised paragraph 1.2, B.***

**B. Special Conditions: The heating water piping must be installed through the Lot 50 parking garage by December 1, 2014. (All work shown on MP-101)**

- C. Architect Identification: The Contract Documents, dated May 2, 2014, were prepared for the Project by: HDR Architecture, Inc., 8404 Indian Hills Drive, Omaha, NE 68114-4098.
- D. Owner's Project Coordinator: An employee appointed from Facilities Management and Planning will be designated to serve as Owner's Project Coordinator for purpose of this Contract.
  - 1. Contractor shall cooperate with, continual advise, coordinate and communicate with Owner's Project Coordinator regarding progress of the Work, scheduling, prior notices of special arrangements necessary to move materials and equipment over Owner's site or through buildings, to cause mechanical and electrical outages and to perform any other operations which will affect normal use of any of Owner's facilities.
  - 2. Owner's Project Coordinator will cooperate with Contractor and convey Contractor's reports, notices and other information to those having Owner's interest or responsibility for this Contract.

1.3 CONTRACT

- A. Project will be constructed under a single general construction contract.

1.4 WORK SEQUENCE

- A. Not applicable.

1.5 WORK UNDER OTHER CONTRACTS

- A. Separate Contract: Owner will award separate contract for performance of certain construction operations at the Project site. Those operations will be conducted simultaneously with work under this Contract.
  - 1. Those Contracts include but are not limited to following:

**SECTION 01 23 00 – ALTERNATES (Revised AD-1)**

**PART 1 - GENERAL**

1.1 RELATED DOCUMENTS

- A. Drawings and general provisions of the Contract, including General Conditions and other Division 1 Specification Sections, apply to this Section.

1.2 SUMMARY

- A. This Section includes administrative and procedural requirements governing Alternates.

1.3 DEFINITIONS

- A. Alternate: An amount proposed by Bidder and stated on Bid Form for certain work defined in Bidding Requirements that may be added to or deducted from Base Bid amount. The Owner may decide to accept a corresponding change in either amount of construction to be completed, or in products, materials, equipment, systems, or installation methods described in Contract Documents.

- 1. Cost for each alternate is net addition to or deduction from Contract Sum to incorporate Alternate into the Work. No other adjustments are made to Contract Sum.

1.4 PROCEDURES

- A. Coordination: Modify or adjust affected adjacent Work as necessary to completely and fully integrate Work of the alternate into the Project.
  - 1. Include as part of each alternate, miscellaneous devices, accessory objects, and similar items incidental to or required for a complete installation whether or not mentioned as part of Alternate.
- B. Notification: Immediately following award of Contract, notify each party involved, in writing, of status of each alternate. Indicate if alternates have been accepted, rejected, or deferred for later consideration.
- C. Execute accepted alternates under same conditions as other Work of this Contract.
- D. Schedule: "Schedule of Alternates" is included at end of this Section. Specification Sections referenced in Schedule contain requirements for materials necessary to achieve the Work described under each alternate.

**PART 2 - PRODUCTS (Not Applicable)**

**PART 3 – EXECUTION**

3.1 SCHEDULE OF ALTERNATES

- A. Alternate No. 1: Utilize grooved mechanical joints for interior, above grade heating hot water system in lieu of welded joints. Refer to Section 23 21 13.

**AD-1: Section 01 23 00; 05/19/2014: Added paragraph 3.1, B.**

- B. Alternate No. 2: Utilize directional boring to install piping under Emile Street in lieu of trenching to allow work to take place during normal working hours while maintaining all lanes of traffic.**

**END OF SECTION 01 23 00**

UNIVERSITY OF NEBRASKA MEDICAL CENTER

1. Prepare similar memoranda for Owner and separate contractors where coordination of their work is required.
- C. Administrative Procedures: Coordinate scheduling and timing of required administrative procedures with other construction activities and activities of other contractors to avoid conflicts and to assure orderly progress of the Work.
  1. Such administrative activities include, but are not limited to:
    - a. Preparation of Contractor's Construction Schedule.
    - b. Preparation of the Schedule of Values.
    - c. Installation and removal of temporary facilities and controls.
    - d. Delivery and processing of submittals.
    - e. Progress meetings.
    - f. Project closeout activities.
- D. Shift Work: Work performed "after-hours" or other than "normal work-hours" shall be coordinated with and have prior approval from Owner's Project Coordinator. .
- E. Conservation: Coordinate construction activities to assure that operations are carried out with consideration given to conservation of utilities and materials.

1.4 SUBMITTALS

*AD-1: Section 01 31 00; 05/19/2014: Revised paragraph 1.4, A.*

**A. Coordination Drawings: Prepare Coordination Drawings for all work indicated on contract documents.**

1. Indicate relationship of components shown on separate Shop Drawings.
2. Indicate required installation sequences.
3. In all mechanical and/or electrical rooms, indicate clear space requirements for proper operation and maintenance of all mechanical, electrical, and plumbing equipment to be installed including relationship with any existing equipment.

*AD-1: Section 01 31 00; 05/19/2014: Added paragraph 1.4, A, 4.*

**4. Contract documents are diagrammatic and indicate general arrangement of systems and equipment. Exact routing of all piping and equipment shall be coordinated with UNMC and submitted and approved through the coordination drawings.**

- B. Staff Names: At pre-construction conference, submit list of Contractor's principal staff assignments, including superintendent and other personnel in attendance at Project Site. Identify individuals and their duties and responsibilities; list addresses and telephone numbers, including home, office, and cellular telephone numbers. Provide names, addresses, and telephone numbers of individuals assigned as standbys in the absence of individuals assigned to Project.

1.5 PROJECT MEETINGS

- A. General: Schedule and conduct meetings and conferences at Project site, unless otherwise indicated.
  1. Attendees: Inform participants and others involved, and individuals whose presence is required, of date and time of each meeting. Notify Owner and Architect of scheduled meeting dates and times.

**SECTION 20 05 19**  
PIPING SPECIALTIES (Reissued AD-1)

**PART 1 - GENERAL**

**1.1 SUMMARY**

- A. Furnish labor, materials, tools, equipment, and services for Piping Specialties, as indicated, in accordance with provisions of Contract Documents.
- B. Systems Included:
  - 1. Expansion joints.
  - ~~2. Pressure gauges.~~
  - 3. System drains.
  - ~~4. Thermometer wells and test gauge connections.~~
  - ~~5. Thermometers.~~
  - ~~6. Wye strainers for steam and hydronic systems.~~
- C. Completely coordinate with work of other trades.

**1.2 QUALITY ASSURANCE**

- A. Comply with applicable UL, ANSI and ASTM Standards.

**1.3 SUBMITTALS**

- A. Shop Drawings:
  - 1. Layout of piping showing expansion joints and manufacturer recommended locations for pipe anchor and guide locations.
  - 2. Include axial, lateral, and vertical stresses at anchors as calculated by expansion joint manufacturer. Stresses shall be compliant with ASME B31.1 requirements.
- B. Product Data:
  - 1. Expansion joints.
  - ~~2. Pressure gauges.~~
  - ~~3. Thermometers.~~
  - ~~4. Wye strainers.~~

**PART 2 - PRODUCTS**

**2.1 ACCEPTABLE MANUFACTURERS**

- A. Expansion joints, flexible hose type:
  - 1. Base:
    - a. Metraflex.
  - ~~2. Optional:~~
    - ~~a. Senior Flexonics Pathway.~~
    - ~~b. American Boa Inc.~~
    - ~~c. Hyspan Precision Products, Inc. (Bareo).~~
- ~~B. Pressure gauges:~~
  - ~~1. Base:~~
    - ~~a. Weiss Instruments.~~
  - ~~2. Optional:~~

- a. ~~Trerice, HO.~~
- b. ~~Marsh Instrument.~~
- c. ~~US Gauge.~~
- d. ~~Weiss Instruments.~~
- e. ~~Weksler Instruments.~~
- f. ~~Weston and Ernst.~~
- g. ~~Winters.~~

**C. ~~Thermometers and Pressure Gauges:~~**

- 1. ~~Base:~~
  - a. ~~Weiss Instruments.~~
- 2. ~~Optional:~~
  - a. ~~Marsh Instrument.~~
  - b. ~~Marshalltown Instrument.~~
  - c. ~~Palmer Instruments.~~
  - d. ~~Taylor Environmental Instruments.~~
  - e. ~~Trerice, HO.~~
  - f. ~~Weiss Instruments.~~
  - g. ~~Weksler Instruments.~~
  - h. ~~Weston and Ernst.~~
  - i. ~~Asheroft.~~
  - j. ~~Winters.~~

**D. ~~Wye strainers:~~**

- 1. ~~Base:~~
  - a. ~~Armstrong International~~
- 2. ~~Optional:~~
  - a. ~~Armstrong International.~~
  - b. ~~Spirax Sareo.~~
  - c. ~~Keekley, OC.~~
  - d. ~~Metraflex.~~
  - e. ~~Mueller Steam Specialty.~~
  - f. ~~Spence Engineering.~~
  - g. ~~Vietaulic of America.~~

**E. ~~Other manufacturers desiring approval comply with Section 00-26-00.~~**

**2.2 EXPANSION JOINTS**

**A. Expansion joints, bellows type:**

- 1. Suitable for 175 PSI working pressure and 200 degF maximum temperature.
- 2. ~~In 2-1/2 IN and smaller lines:~~
  - a. ~~Expansion compensator type with external shrouds.~~
  - b. ~~Bellows: Stainless steel.~~
  - c. ~~Shrouds and end fittings: Carbon steel or bronze (compatible with system piping material).~~
- 3. In 3 IN and larger lines:
  - a. Construction: Stainless steel.
  - b. Braid: Stainless steel.
  - c. Flanges: Consistent with pipe material.
  - d. Rated movement: As indicated on plans.

**2.3 PRESSURE GAUGES**

**A. ~~Pressure gauges:~~**

- 1. ~~Steam systems and water systems operating above 150 degF:~~
  - a. ~~Case and twist ring: 4-1/2 IN diameter, anodized aluminum.~~
  - b. ~~Socket: brass.~~

- ~~e. Bourdon tube: Phosphor bronze.~~
- ~~d. Movement: Bushed Brass Rotary.~~
- ~~e. Dial: White aluminum, black markings.~~
- ~~f. Pointer: Black or red anodized aluminum, slotted adjustable.~~
- ~~g. Window: Glass.~~
- ~~a. Siphon and gauge cock (low pressure steam): brass.~~
- ~~b. Siphon and needle valve (medium and high pressure steam): brass..~~
- ~~e. Accuracy: 1.0% full scale, ASME B40.1 Grade 1A.~~
- ~~d. Range: Operating pressure to occur in middle half (25 % to 75%) of the full scale range of the fluid being measured.~~
- ~~e. Connections: 1/4 IN or 1/2 IN NPT.~~
- ~~2. Compressed air systems and water systems operating below 150 degF~~
  - ~~a. Case and Ring: 4 IN diameter, liquid filled, type 304 stainless steel case with polished stainless steel bayonet ring.~~
  - ~~b. Fill liquid: Glycerin.~~
  - ~~c. Socket: Brass with push-in restrictor.~~
  - ~~d. Bourdon tube: Phosphor Bronze.~~
  - ~~e. Movement: Brass rotary type with bushings.~~
  - ~~f. Dial: White aluminum with black markings.~~
  - ~~g. Pointer: Black or red anodized aluminum, adjustable.~~
  - ~~h. Window: Clear acrylic.~~
  - ~~i. Snubber and gauge cock: Chrome plated brass.~~
  - ~~j. Accuracy: 1.0% full scale, ASME B40.1 Grade 1A.~~
  - ~~k. Range:~~
    - ~~1) Refer to pressure range schedule except as follows:~~
      - ~~a) Pump suction gauges for open piping systems where elevation difference between pump center line and liquid level of open system is less than 50 feet: Compound type, indicating at least 30 IN Hg to 30 PSIG.~~
      - ~~b) Fuel oil pump suction: Compound type, indicating to 210kPa 30 IN Hg to 30 PSIG.~~
    - ~~l. Connections: 1/4 IN or 1/2 IN NPT.~~
- ~~3. Pressure gauge range schedule:~~

	Range	Fig. Interval	Inter. Graduations	Bldg. Height Stories
	PSIG	PSIG	PSIG	
Heating hot water	0-160	20	2	over 4

**2.4 SYSTEM DRAINS**

- A. Valved drains (nonpotable water):
  - 1. Piping 2 IN and smaller:
    - a. 1/2 IN V-13, or V-14 with male hose-thread outlet and brass cap.
  - 2. Piping 2-1/2 IN and larger:
    - a. 1-1/2 IN V-13 or V-14 ball valve with 1-1/2 IN fire hose adapter and cap.
- ~~B. Valved drains (potable water):~~
  - ~~a. 1/2 IN V-13 with plugged outlet.~~
- C. On nonpotable systems, label system drains as nonpotable.
- D. Valve standards: See section 20 05 23.

**2.5 THERMOMETER WELLS (SOCKETS) AND TEST GAUGE CONNECTIONS**

- ~~A. Temperature sensing wells (sockets) and test gauge connections:~~
  - ~~1. Brass or stainless steel.~~

~~2. Provide extension necks for insulated piping.~~

## ~~2.6 THERMOMETERS~~

### ~~A. BiMetal Thermometers:~~

- ~~1. Case: Type 304 Stainless Steel.~~
- ~~2. Window: Shatterproof glass or acrylic.~~
- ~~3. Stem assembly: Stainless steel all welded construction and 1/2 IN NPT connection.~~
- ~~4. Element fluid: Silicone.~~
- ~~5. Dial: Heavy gauge aluminum, white finish, black or red graduation lines and numerals.~~
- ~~6. Accuracy: 1% of scale range.~~

### ~~B. Liquid filled thermometers:~~

- ~~1. Case: Industrial type molded polyester or die cast aluminum.~~
- ~~2. Window: Shatterproof glass or acrylic.~~
- ~~3. Liquid: Red reading mercury.~~
- ~~4. Scale: 9 IN scale minimum, black lines and numbers.~~
- ~~5. Accuracy: 1% of scale range.~~
- ~~6. Angle adjustment: variable with angle adjusting screw.~~

### ~~C. Digital Thermometers:~~

- ~~1. Case: High impact ABS.~~
- ~~2. Display: 1/2 IN m LCD digits.~~
- ~~3. Sensor: Glass passivated thermistor.~~
- ~~4. Ambient Operating conditions: -30 degF to 140 degF.~~
- ~~5. Accuracy 1% of reading or 1 degF.~~
- ~~6. Resolution: .1 degF between -20 degF and 200 degF.~~
- ~~7. Recalibration: Through case potentiometer adjustment.~~
- ~~8. Lux rating: 10 Lux (one foot candle).~~
- ~~9. Update span: 10 seconds.~~
- ~~10. Range: -50 degF to 300 degF. Switchable from Metric to English scale.~~
- ~~11. Ambient temperature error: Zero.~~
- ~~12. Maximum ambient humidity: 100 percent.~~
- ~~13. Power: Solar.~~

### ~~D. Thermometers range schedule:~~

	<del>Range</del>	<del>Division</del>
	<del>degF</del>	<del>degF</del>
<del>Heating hot water</del>	<del>50-300</del>	<del>2</del>

## ~~2.7 WYE STRAINERS FOR STEAM AND HYDRONIC SYSTEMS~~

### ~~A. Wye strainers:~~

- ~~1. Screwed or flanged.~~
- ~~2. Body:~~
  - ~~a. 2 IN and smaller:~~
    - ~~1) Cast bronze, ASTM B62, screwed ends.~~
  - ~~b. 2-1/2 IN and larger:~~
    - ~~1) Cast iron, flanged ends.~~
    - ~~2) Coating: Rust inhibiting.~~
- ~~3. Working pressure, non shock: 150 PSIG.~~
- ~~4. Screens:~~
  - ~~a. Water: Bronze, monel or stainless steel.~~
    - ~~1) 2 IN and less: 3/64 IN perforations.~~
    - ~~2) 2-1/2 IN and larger: 1/8 IN perforations.~~

## PART 3 - EXECUTION

### 3.1 GENERAL

- A. Install piping specialties according to manufacturer instructions and as specified.

### 3.2 EXPANSION JOINTS

- A. Expansion joints in hot water and steam piping, bellows type:
  1. Suitable for 175 psig working pressure and 200 degF maximum temperature.
  2. Provide pipe guides at 14 pipe diameters from each expansion joint.
  3. Install pipe guides in accordance with Expansion Joint Manufacturers Association Standard.
  4. ~~Size in accordance with manufacturer's recommendation, with 30 percent excess traverse available at maximum expansion.~~
  5. ~~Axial traverse indicated includes 30 percent excess.~~

### 3.3 ~~PRESSURE GAUGES~~

- ~~A. Install filter type pressure snubbers at pumps and chillers.~~
- ~~B. Install siphons on steam gauges.~~
- ~~C. Install brass tee handle cock and 1/4 IN hard tempered tubing from gauge to pipe connection.~~
- ~~D. Install additional brass tee handle cock at gauge for panel mounted gauge.~~
- ~~E. Calibrate and zero gauges at job site.~~

### 3.4 SYSTEM DRAINS

- A. At low points of piping systems, provide valved drains to allow complete drainage of each system.
- B. Neither terminate nor run drains over electrical equipment.

### 3.5 ~~THERMOMETER WELLS AND TEST GAUGE CONNECTIONS~~

- ~~A. Provide test thermometer well adjacent to each point where a temperature sensing device is required by control specifications and where piping schematics indicate thermometers.~~
- ~~B. Placement and sizing:
  1. ~~For 4 IN piping and larger, place tee in piping to create perpendicular flow to stem measurement.~~
    - ~~a. Size stem length based on pipe size as indicated below:~~
      - 1) ~~4 and 5 IN pipe: 3 1/2 IN stem.~~
      - 2) ~~6 and 8 IN pipe: 6 IN stem.~~
      - 3) ~~10 and 12 IN pipe: 9 IN stem.~~
      - 4) ~~14 IN pipe and larger: 12 IN stem.~~
    2. ~~For piping smaller than 4 IN, place oversize piping well and tee in 90 degree piping turn to create parallel flow to stem measurement.~~
      - ~~a. Stem length: 12 IN.~~
      - ~~b. Piping well length: 14 IN.~~
      - ~~c. Size piping well and tee based on pipe size as indicated below:~~
        - 1) ~~1/2 and 3/4 IN pipe: 1 1/4 IN well and tee.~~
        - 2) ~~1 IN pipe: 1 1/2 IN well and tee.~~
        - 3) ~~1 1/4 and 1 1/2 IN pipe: 2 IN well and tee.~~
        - 4) ~~2 IN pipe: 2 1/2 IN well and tee.~~
        - 5) ~~2 1/2 and 3 IN pipe: 4 IN well and tee.~~~~

### **3.6 THERMOMETERS**

- A. Where temperature control requires a temperature transmitter, a thermometer is not required in same location unless specifically required in equipment specifications.**
- B. Where 2 or more pumps are headered, provide one thermometer in suction header and one in discharge header.**

### **3.7 WYE STRAINERS**

- A. Provide wye strainers as indicated in piping system sections.**
- B. Connections to suit piping system.**
- C. Provide blow down valves:**
  - 1. Strainers 6 IN and larger: 1 1/2 IN blow down valve.  
a. Pipe blow down to drain.**
  - 2. Strainers 2 to 5 IN: 1 IN blow down valve with 3/4 IN hose end connection and brass cap.**
  - 3. Strainers 1 1/2 IN and smaller: 1/2 IN blow down valve with 3/4 IN hose end connection and brass cap.**

**END OF SECTION**

**SECTION 20 05 23**  
**MANUAL VALVES (Reissued AD-1)**

**PART 1 - GENERAL**

**1.1 SUMMARY**

- A. Furnish labor, materials, tools, equipment, and services for Manual Valves, as indicated, in accordance with provisions of Contract Documents.
- B. Definitions:
  - 1. Class: ANSI Class.
  - 2. SWP: Steam Working Pressure.
  - 3. WOG: Water/Oil/Gas non-shock working pressure.
  - 4. WWP: Cold water non-shock working pressure.
- C. Completely coordinate with work of other trades.

**1.2 QUALITY ASSURANCE**

- A. This specification lists a variety of valves that may be applicable to the project. Not all valves listed are applicable to the project, refer to appropriate specs sections for project applicability.
- B. Boiler system valves: ASME Boiler Code Specifications.
- C. Fire protection valves: UL listed, NFPA and FM approved.
- D. Valves used in flammable liquid or flammable gas systems: UL listed for applicable service.
- E. Valves cleaned for oxygen service: CGA Pamphlet G-4.1, Cleaning Equipment for Oxygen Service.
- F. Valve bodies, shells and seats: Designed, manufactured, and tested in accordance with the following:
  - 1. Ball valves: Federal Specification WW-V-35.
  - 2. Pressure testing of steel valves: MSS SP-61.
  - 3. Butterfly valves: MSS SP-67.
  - 4. Butterfly valves, bronze: Federal Specification WW-V-1967.
  - 5. Cast iron gate valves, flanged and threaded ends: MSS SP-70.
  - 6. Cast iron swing check valves, flanged and threaded ends: MSS SP-71.
  - 7. Cast iron plug valves, flanged and threaded ends: MSS SP-78.
  - 8. Bronze gate, globe, angle and check valves: MSS SP-80.
  - 9. Valve pressure testing methods: MSS SP-82.
  - 10. Cast iron globe and angle valves, flanged and threaded ends: MSS SP-85.
  - 11. Diaphragm type valves: MSS SP-88.
  - 12. Resilient seated eccentric cast iron plug valves: MSS SP-108.
  - 13. Ball valves--threaded, socket-welding, solder joint, grooved, and flared ends: MSS SP-110.
- G. Standard Specification for Composition of Bronze or Ounce Metal Castings: ASTM-B62.
- H. Standard Specification for Steam or Valve Bronze Castings: ASTM-B61.
- I. Iron body valves:
  - 1. Pressure containing parts: ASTM-A126, Grade-B.
    - a. Standard Specification for Gray Iron Castings for valves, flanges and pipe fittings: ASTM-A126, Grade B.

2. Face to face and end to end dimensions: ANSI/ASME-B16.10.
  3. Use domestic manufactured valves as defined by Buy American Act.
- J. Valve stems: ASTM-B371, Alloy C69400; ASTM-B371, Alloy C65100H04 (rolled silicon brass); or other material equally resistant to dezincification.
- K. Indicate following information on valves:
1. Stamped or cast into body:
    - a. Manufacturer's name or trademark.
    - b. Pressure rating as Class, SWP, WOG, or WWP.
    - c. "UL-FM" for UL-FM valves.
  2. Permanently attached to body:
    - a. Valve's country of origin.

### 1.3 SUBMITTALS

- A. Product Data:
1. Valves.
    - a. In addition to submittal requirements of Section 01 33 00, submittal shall include the following:
      - 1) For submittals with model numbers not listed in this section, include published cross reference sheet. Indicate association between submitted model number and the listed model number on the cross reference sheet.
      - 2) For each valve submitted indicate in which specification section(s) and in which system(s) the valve will be used.
    - b. When valve assembly includes components other than the base valve body and handle (e.g., operator, valve box), include data on entire valve assembly.

## PART 2 - PRODUCTS

### 2.1 ACCEPTABLE MANUFACTURERS

~~A. Angle valves:~~

~~1. Base:~~

~~a. Milwaukee Valve.~~

~~2. Optional:~~

~~a. Crane Valves.~~

~~b. Hammond Valve.~~

~~c. Jenkins Valves.~~

~~d. Lunken.~~

~~e. Powell.~~

~~f. Walworth.~~

B. Ball valves:

1. Base:

a. Milwaukee Valve.

2. Optional:

a. Apollo.

b. Crane Valves.

c. Hammond Valve.

d. Jamesbury.

e. Jenkins Valves.

f. Stockham.

g. Victaulic (grooved end valves).

C. Butterfly valves:

1. Base:

a. Jamesbury

2. Optional:
  - a. DeZurik.
  - b. Milwaukee Valve.
  - c. Stockham.
  - d. Victaulic of America.
  - e. Crane Valves.
  - f. Hammond Valve.
  - g. Lunken.
  - h. Powell.

**~~D. High Performance Butterfly Valves:~~**

- ~~1. Base:~~
  - ~~a. Jamesbury~~
- ~~2. Optional:~~
  - ~~a. Bray Controls.~~
  - ~~b. Crane~~
  - ~~c. Dezurik~~
  - ~~d. ABZ~~

**~~E. Check valves:~~**

- ~~1. Base:~~
  - ~~a. Milwaukee Valve.~~
- ~~2. Optional:~~
  - ~~a. Apeo Valve & Primer.~~
  - ~~b. Crane Valves.~~
  - ~~c. Hammond Valve.~~
  - ~~d. Kennedy Valve.~~
  - ~~e. Milwaukee Valve.~~
  - ~~f. Mueller Steam Specialty.~~
  - ~~g. Powell.~~
  - ~~h. Victaulic of America.~~
  - ~~i. Viking.~~

**~~F. Gate Valves:~~**

- ~~1. Base:~~
  - ~~a. Milwaukee Valve.~~
- ~~2. Optional:~~
  - ~~a. Crane Valves.~~
  - ~~b. Hammond Valve.~~
  - ~~c. Jenkins Valves.~~
  - ~~d. Kennedy Valve.~~
  - ~~e. Milwaukee Valve.~~
  - ~~f. Mueller Steam Specialty.~~
  - ~~g. Powell.~~

**~~G. Globe valves:~~**

- ~~1. Base:~~
  - ~~a. Milwaukee Valve.~~
- ~~2. Optional:~~
  - ~~a. Crane Valves.~~
  - ~~b. Hammond Valve.~~
  - ~~c. Jenkins Valves.~~
  - ~~d. Lunken.~~
  - ~~e. Powell.~~

**H. ~~Plug valves:~~**

- 1. ~~Base:~~**
  - ~~a. DeZurik.~~
- 2. ~~Optional:~~**
  - ~~a. Milliken.~~
  - ~~b. Mueller Steam Specialty.~~
  - ~~c. Rockwell International.~~
  - ~~d. Victaulic of America.~~
  - ~~e. Resun Valves.~~

**I. ~~Valve boxes and stop boxes:~~**

- 1. ~~Base:~~**
  - ~~a. Tyler Pipe.~~
  - ~~b. Western.~~
- 2. ~~Optional:~~**
  - ~~a. Neenah Foundry.~~
  - ~~b. Vulean.~~
  - ~~c. Local foundry.~~

**J. ~~Balancing valves (globe style):~~**

- 1. ~~Base:~~**
  - ~~a. Tour and Andersson.~~
- 2. ~~Optional:~~**
  - ~~a. Armstrong.~~
  - ~~b. Wheatley.~~
  - ~~c. Mepeco.~~

K. Other manufacturers desiring approval comply with Section 00 26 00.

## **2.2 MATERIALS**

**A. Ball valves:**

1. Port size: Full.
2. Ball and stem material: 316 Stainless Steel unless noted otherwise in specific valve description.
3. Blow-out proof stems.
4. Reinforced Teflon (PTFE) seats.
5. Teflon (PTFE) seals.
6. Adjustable packing.
7. 3-piece valves:
  - a. Repairable in line.

**B. Butterfly valves:**

1. Ninety degree operation.
2. Bi-directional, bubble-tight shut off at full pressure rating (200 psig minimum dead end service).
3. 2 IN extended neck.
4. Lugs, where specified, shall be drilled and tapped or flanged.
5. Operators:
  - a. 2-1/2 to 4 IN: Position lock handle.
  - b. 5 IN and larger: gear operator with 4-arm or wheel handle.
6. Iron or Steel body:
  - a. Seals shall be replaceable without removing valve from line or removing parts other than operator.
7. Bronze:
  - a. Blow-out proof stem.
  - b. Viton seals.

c. Pressure rating: 175 PSI WWP, 350 PSI WOG.

**C. ~~High-performance butterfly valves:~~**

- ~~1. Ninety-degree operation.~~
- ~~2. Bi-directional, drip-tight shut-off at full pressure rating (200 psig minimum dead-end service).~~
- ~~3. 2 IN extended neck.~~
- ~~4. Lugs shall be drilled and tapped or flanged.~~
- ~~5. Operator: gear type with 4-arm or wheel handle.~~
- ~~6. Body: carbon steel.~~
- ~~7. Disc: stainless steel.~~
- ~~8. Seat: RTFE.~~
- ~~9. Stem: stainless steel; blow-out proof.~~
- ~~10. Taper pins: compression type; stainless steel.~~
- ~~11. ANSI Class: 150.~~
- ~~12. Applicable fire test standard: API-607.~~

**D. ~~Chain operators:~~**

- ~~1. Provide operators for valves located in mechanical spaces 8 FT or higher above floor.~~
- ~~2. Chain lever or chain sprocket operator with sufficient chain to reach within 6 FT of floor.~~
- ~~3. Remote operator accessories by same manufacturer as valve.~~
- ~~4. Do not provide for Fire Protection valves.~~

**E. End styles, general:**

1. Compatible with piping systems served.
2. Flanged valves:
  - a. Class 125 cast iron: Flat flanges.
  - b. Class 250 cast iron: Raised flanges.
  - c. Ductile iron: Raised flanges.
3. Valves with solder ends for use in brazed piping systems shall be constructed for brazing.

**F. Extended necks and stems:**

1. For valves specified with extended necks or stems, provide design that isolates moving valve parts from insulation.
2. For valves specified with extended necks or stems and memory stops, provide design that allows access to memory stop without disturbing insulation.

G. Packing shall not contain asbestos.

## 2.3 VALVES

**A. General:**

1. Example model numbers may indicate a general series, or may be abbreviated. They may not reflect all features described. Provide valves with described features.
2. Specified requirements are minimums. Valves that meet or exceed specifications may be submitted.

~~**B. V-1: Gate valve, Class 125, bronze body, screwed bonnet, non-rising stem, solid wedge disc, solder. Example: Milwaukee 115.**~~

~~**C. V-2: Gate valve, Class 150, bronze body, union bonnet, rising stem, solid wedge disc, threaded. Example: Milwaukee 1151.**~~

~~**D. V-3: Gate valve, Class 125, cast iron body, bronze trim, bolted bonnet, rising stem, OS&Y, solid wedge disc, flanged. Example: Milwaukee F-2891.**~~

~~**E. V-4: Gate valve, same as V-2 except Class 200. Example: Milwaukee F-1153.**~~

~~**F. V-5: Gate valve, same as V-3 except Class 250. Example: Milwaukee.**~~

- ~~G. V-6: Globe valve, Class 150, bronze body, union bonnet, renewable Teflon disc, solder. Example: Milwaukee 1590.~~
- ~~H. V-7: Globe valve, same as V-6 except threaded. Example: Milwaukee 590.~~
- ~~I. V-8: Globe valve, Class 125, cast iron body, bronze trim, bolted bonnet, OS&Y, renewable seat and bronze disc, flanged. Example: Milwaukee F-2982.~~
- ~~J. V-9: Globe valve, Class 200, bronze body, union bonnet, renewable plug type seat and disc, threaded. Example: Milwaukee 570.~~
- ~~K. V-10: Globe valve, same as V-8 except Class 250. Example: Milwaukee F-2983.~~
- ~~L. V-11: Ball valve, 150 PSI SWP, 400 PSI WOG bronze body, adjustable memory stop, 2-piece construction, stainless steel ball and stem, reinforced Teflon seats, extended stem, solder. Example: Apollo 70-240 Series.~~
- ~~M. V-12: Ball valve, same as V-11 except threaded. Example: Apollo 70-140 Series.~~
- N. V-13: Ball valve, 150 PSI SWP, 400 PSI WOG bronze body, 2-piece construction, stainless steel ball and stem, reinforced Teflon seats, extended stem, solder. Example: Apollo 70-240 Series.
- O. V-14: Ball valve, same as V-13 except threaded. Example: Apollo 70-140 Series.
- ~~P. V-15: Ball valve, 150 PSI SWP, 400 PSI WOG, 29 IN Hg vacuum service, bronze body, 3-piece construction, cleaned and capped for oxygen service, lockable in either the open or closed position, color coded handle to match gas service, braze. Example: Milwaukee BA-30BS.~~
- ~~Q. V-16: Ball valve, 150 PSI SWP, 600 PSI WOG, 250 PSI UL listed for flammable liquids and LP gas, bronze body, 2-piece construction, full or standard port, bronze ball, non-lubricated, threaded. Example: Milwaukee BA-475.~~
- ~~R. V-17: Angle valve, Class 125, bronze body, screwed bonnet, bronze disc, threaded. Example: Stockham B-216.~~
- ~~S. V-18: Angle valve, Class 125, cast iron body, bolted bonnet, bronze trim, renewable seat and disc, flanged. Example: Stockham G-512.~~
- ~~T. V-19: Angle valve, Class 200, bronze body, union bonnet, bronze disc, threaded. Example: Stockham B-237.~~
- ~~U. V-20: Angle valve, Class 250, cast iron body, bronze trim, flanged. Example: Stockham F-541.~~
- ~~V. V-21: Angle valve, automatic stop check, Class 250, cast iron body, bolted bonnet, renewable disc and seat, flanged. Example: Stockham F-541.~~
- ~~W. V-22: Check valve, in-line pattern, spring-operated double doors, Class 250, cast iron body, renewable bronze doors and Viton-A seal, Inconel springs, stainless steel trim, flat faced wafer. Example: Gulf MB25-50.~~
- ~~X. V-23: Check valve, Y-pattern, horizontal swing, Class 150, bronze body, threaded cap, renewable Teflon disc and seat, threaded. Example: Crane 141TF.~~
- ~~Y. V-24: Check valve, Y-pattern, horizontal swing, Class 125, bronze body, threaded cap, renewable bronze disc and seat, threaded. Example: Crane 37.~~
- ~~Z. V-25: Check valve, same as V-23 except Class 125. Example: Crane 41TF.~~
- ~~AA. V-26: Check valve, in-line pattern, spring-operated disc, Class 125, bronze body, renewable Teflon disc and seat, 316 stainless steel spring, threaded. Example: Milwaukee 548-T~~

- ~~BB. V 27: Check valve, T-pattern, horizontal lift, Class 150, bronze body, union bonnet, renewable Teflon disc and seat, threaded. Example: Stockham B-322-T.~~
- ~~CC. V 28: Check valve, T-pattern, horizontal swing, Class 125, cast iron body, bolted bonnet, bronze trim, renewable bronze or cast iron disc and seat, flanged. Example: Milwaukee F-2974.~~
- ~~DD. V 29: Check valve, in-line pattern, spring-operated double doors, Class 125 (cast iron body) or Class 150 (steel body), Buna-N or EPDM seal, aluminum bronze or stainless steel doors, 316 stainless steel spring; grooved, threaded, flanged, wafer, or lugged at locations other than equipment; grooved, flanged or lugged if between equipment and its isolation valve. Example: APCO L9000.~~
- ~~EE. V 30: Check valve, silent, in-line pattern, spring-operated disc, Class 125, cast iron body, renewable bronze disc and seat, stainless steel spring, flat faced wafer. Example: Milwaukee 1400.~~
- ~~FF. V 31: Check valve, same as V-23 except Class 200. Example: Crane 36.~~
- ~~GG. V 32: Check valve, same as V-28 except Class 250. Example: Milwaukee F-2970.~~
- ~~HH. V 33: Butterfly valve, 250 PSI WWP; 27 IN Hg vacuum; cast or ductile iron body; EPT(EPDM) sleeve; stainless steel stem; aluminum-bronze or stainless steel disc; lugged. Example: Jamesbury 830LHV.~~
- ~~H. V 34: Butterfly valve, same as V-33 except wafer. Example: Jamesbury 830WHV.~~
- JJ. V-35: Butterfly valve, 250 PSI WWP; cast or ductile iron body; EPT(EPDM) sleeve; stainless steel stem; nylon ductile coated or stainless steel disc; lugged. Example: Bray 31H .
- ~~A. V 36: Eccentric plug valve, 175 PSI WOG, cast iron body, bronze or nickel plated cast-iron plug, Isobutene-Isoprene steam and plug seals, high-temperature plug face, capped drip tap on seat end of valve, memory stop, lever handle, threaded. Example: DeZurik 499S.~~
- ~~B. V 37: Eccentric plug valve, 175 PSI WWP for 12 IN and smaller, 150 PSI WWP for 14 IN and larger, cast iron body, Viton filled TFE U-ring seal, Isobutene-Isoprene plug face, memory stop; lever handle for sizes 2-1/2 to 4 IN; gear operator with handwheel actuator for sizes 6 IN and larger; flanged. Example: DeZurik 118F.~~
- ~~C. V 38: Eccentric plug valve, same as V-36 except flanged, or grooved. Example: DeZurik 499.~~
- ~~D. V 39: Ball valve, same as V-13 and V-14 except include adjustable memory stop. Example: Milwaukee BA-200 and BA-250.~~
- ~~E. V 40: Butterfly valve, seat and carbon filled enhanced PTFE seal, carbon steel body, 316 SS disc. Example: Jamesbury Series 815.~~
- ~~F. V 41: Plug valve, lubricated, 200 PSI WOG, semi-steel, bottom or bolted top entry, UL listed for application, lubricant compatible with application, short pattern flanged. Example: Resun R-1431.~~
- ~~G. V 42: Not used.~~
- ~~H. V 47, Gate valve with valve box:~~
- ~~1. Gate valve, AWWA-C500, 200 PSI WWP for 12 IN and smaller, 150 PSI for 14 IN and larger, iron body, bronze mounted, bronze or cast iron double disc, non-rising stem, parallel seat, mechanical joint. Example: Stockham G-743.~~
  - ~~2. Valve box: coated cast-iron, 5-1/4 IN shaft, screw type, 3-piece, drop-in lid with cast-in marking indicating service. Example: Tyler 6860.~~
- ~~I. V 48, Butterfly valve with valve box:~~

1. ~~Butterfly valve, AWWA C504, Class 150, iron body, stainless steel seat, aluminum-bronze or cast iron disc, natural rubber or Buna-N seat, mechanical joint. Example: DeZurik BAW.~~
  2. ~~Valve box: coated cast iron, 5-1/4 IN shaft, screw type, 3-piece, drop-in lid with cast-in marking indicating service. Provide extensions on the valve screw/box as required for head to be 2' or less below the surface. Example: Tyler 6860.~~
- ~~J. V-49: Gate valve, UL-FM, 1205 kPa 400 PSI WWP, bronze body, union or screwed bonnet, solid wedge disc, OS&Y, threaded. Example: Nibco KT-291-W3.~~
- ~~K. V-50: Gate valve, UL-FM, 1205 kPa 250 PSI WWP, cast iron body, bolted bonnet, resilient solid wedge disc, OS&Y, flanged or grooved. Example: Nibco F-607/FG-607.~~
- ~~L. V-51: Butterfly valve, UL-FM, 1205 kPa 250 PSI WWP, ductile iron body, O-Ring seals, aluminum-bronze or ductile iron disc, stainless steel stem, Buna-N seal, manual geared operator with visual position indicator, wafer or grooved. Example: Nibco WD-3510/GD-4765.~~
- ~~M. V-52: Gate valve, UL-FM, AWWA C-509, 1205 kPa 175 PSI WWP, cast iron body, resilient wedge, non-rise stem, indicator post flange, MJ or flanged. Example: Stockham G-600/601/602.~~
- ~~N. V-53: Check valve, T-pattern, horizontal swing, UL-FM, 1205 kPa 250 PSI WWP, cast iron body, bolted bonnet, bronze trim, renewable bronze or cast iron disc and seat, flanged. Example: Nibco F-938-31.~~
- ~~O. V-54: Check valve, in-line, spring-operated single or double door(s), UL-FM, 1380 kPa 200 PSI WWP, cast iron body, renewable bronze door and rubber or EPDM seat, stainless steel spring, wafer or grooved. Example: Stockham WG-990.~~
- ~~P. V-55: Butterfly valve, UL listed, 1205 kPa 175 PSI WWP, bronze body, stainless steel stem and disc, Viton seal, threaded. Example: Milwaukee BB2-100.~~
- ~~Q. V-56: Butterfly valve, same as V-40 except include extended neck, solder. Example: Milwaukee BB2-350.~~
- ~~R. V-57: Butterfly valve, same as V-40 except include extended neck, threaded. Example: Milwaukee BB2-100.~~
- ~~S. V-58: Not used.~~
- ~~T. V-59: Butterfly valve, same as V-55 with tamper switch. Example: Milwaukee BB2-100.~~
- ~~U. V-60: Plug valve, lubricated, 870 kPa 125 PSI WOG semi-steel, bottom or bolted-top entry, UL listed for application, lubricant compatible with application, threaded. Example: Resun R-1430.~~
- ~~V. V-61: Butterfly valve, UL-FM, 1205 kPa 300 PSI WWP, coated ductile iron body, ductile iron disk with nickel coating, manual geared operator with visual position indicator and weather-proof actuator with two prewired supervisory switches, grooved. Example: Victaulic Series 705 and Series 765.~~
- ~~W. V-62: Butterfly valve, 300 PSI WOG, 27 IN vacuum, copper tube dimensioned, bronze body, ductile iron disk with EPDM coating, extended neck, grooved. Example: Victaulic Series 608.~~
- ~~X. V-63: High performance butterfly valve, Class 150, carbon steel body, RTFE seat, stainless steel shaft, stainless steel disc, TFE packing, lugged. Example: Jamesbury 815L.~~

- ~~Y. V-64: Globe style balancing valve, Y-pattern design, rated for 300 PSI WWP and 250 degF, cast copper alloy (Ametal®) construction, dual pressure/temperature read-out ports, calibrated handwheel with minimum (4) 360 degree adjustment turns and hidden tamper-proof memory stop, threaded or sweat connections and suitable for positive shut-off. Example: Tour and Andersson STAD/STAS. Series 786, 787 & 78K.~~
- ~~Z. V-65: Globe style balancing valve, Y-pattern design, rated for 250 PSI WWP and 250 degF, ductile iron body fitted with copper alloy components, dual pressure/temperature read-out ports, calibrated handwheel with minimum (5) 360 degree adjustment turns and hidden tamper-proof memory stop, Class 125 flanged or grooved connections, and suitable for positive shut-off. Example: Tour and Andersson STAF/STAG. Series 788 and 789.~~
- ~~AA. V-66: Grooved end ball valves rated for 800 CWP shall be ductile iron with chrome-plated carbon steel ball and stem, standard port, TFE seats and fluoroelastomer seals, manual lever handle or gear operator with hand wheel. Example: Victaulic Series 726.~~
- ~~BB. V-67: Grooved end spring-loaded check valves shall be rated [365][300] CWP, ductile iron body, non-slam, silent type stainless steel or EPDM coated ductile iron disc, stainless steel spring, nickel-plated or welded in nickel seat. Example: Victaulic Series 716H and 716. Series 779 shall have venturi taps for flow measurement.~~
- ~~CC. V-68: AGS grooved end check valve 14 In to 24 In. shall be rated for 230 CWP, dual disc design, with ductile iron body, stainless steel disc, spring, and shaft, EPDM seat bonded to the valve body. Example: Victaulic Series W715.~~

## **PART 3 - EXECUTION**

### **3.1 INSTALLATION**

- A. Refer to individual sections for specific valve installation requirements.
- B. Keep valves clear of pull spaces.
- C. Install valves in accessible locations for operation, removal, inspection, and repair of valves and equipment.
- D. Install gate and globe valves with stem in vertical upright to horizontal position.
- E. Install butterfly valves with stem in horizontal position.
- F. Install diaphragm valves to be self draining.
- G. Support valves individually to relieve pipe stress and allow equipment removal.
- H. Follow manufacturer's recommendation for disassembly of valves for end joining method employed.
- I. Provide globe valve in bypass around control valves. Coordinate with Controls Contractor.
- J. Provide shut off valve on each side of control valve. Coordinate with Controls Contractor.

## **END OF SECTION**

**SECTION 20 05 53**

**MECHANICAL IDENTIFICATION SYSTEMS (Reissued AD-1)**

**PART 1 - GENERAL**

**1.1 SUMMARY**

- A. Furnish labor, materials, tools, equipment, and services for Mechanical Identification Systems, as indicated, in accordance with provisions of Contract Documents.
- B. Completely coordinate with work of other trades.

**1.2 QUALITY ASSURANCE**

- A. Piping system identification:
  - 1. ANSI-A13.1, "Scheme for the Identification of Piping Systems".

**1.3 SUBMITTALS**

- A. Product Data:
  - 1. Pipe markers.
  - 2. Valve tags.
  - 3. HVAC duct markers.
  - 4. Equipment name plates.
  - 5. Access panel markers.
  - 6. Underground marking tape.
- B. Contract Closeout Information:
  - 1. Letter of transmittal indicating valve charts installed and delivered.
    - a. Valve Chart: use "Spare Parts and Maintenance Material Transmittal" form per Section 01 78 43.

**PART 2 - PRODUCTS**

**2.1 ACCEPTABLE MANUFACTURERS**

- A. Pipe, valve and equipment markers:
  - 1. Base:
    - a. Seton Name Plate.
  - 2. Optional:
    - a. Brady, WH.
    - b. EMED.
    - c. Kolbi Industries.
    - d. 3M.
    - e. Craftmark Identification Systems.
    - f. Marking Services, Inc.
    - g. Carlton Industries.
    - h. Brimar.
- B. Underground marking tape:
  - 1. Base:
    - a. Reef Industries.
  - 2. Optional:

- a. Seton Name Plate.
- b. EMED.

C. Other manufacturers desiring approval comply with Section 00 26 00.

## 2.2 PIPE MARKERS

- A. Pipe markers: Conform to ANSI-A13.1.
  1. Pressure sensitive vinyl (self-adhesive) material.
  2. Mechanically fastened type: Snap on or strap on.
    - a. For dirty greasy, oily pipe where pressure sensitive markers may not perform satisfactorily.
  3. Provide with arrows indicating direction of flow.
  4. Letter sizes: In accordance with table in Part 3.

## 2.3 VALVE TAGS

- A. Valve tags: Brass or anodized aluminum type.
  1. Brass: Minimum 19 gauge, polished, 1-1/2 IN diameter with following lettering:
    - a. Service: 1/4 IN stamped black filled letters.
    - b. Valve numbers: 1/2 IN stamped black filled letters.
  2. Aluminum: 2 IN diameter, 0.032 IN thick, with following lettering:
    - a. Service: 1/4 IN engraved letters.
    - b. Valve numbers: 1/2 IN engraved letters.
- B. Valve tag fasteners:
  1. 4 ply 0.018 IN copper or monel wire meter seals, brass "S" hooks or No.16 brass jack chain.

## ~~2.4 HVAC DUCT MARKERS~~

### ~~A. HVAC duct markers:~~

- ~~1. 1-1/2 IN black stenciled letters denoting system number (e.g., AHU-1, RF-3, EF-5), type (supply, return, exhaust) and flow direction.~~

## ~~2.5 EQUIPMENT NAME PLATES~~

### ~~A. Equipment name plates:~~

- ~~1. 1/16 IN rigid plastic, "Setonply", "Emedolite" or bakelite with 4 edges beveled; or engraved aluminum with black enamel background and natural aluminum border and letters.~~
  - ~~a. Two 3/8 IN mounting holes.~~
  - ~~b. Lettering size: Minimum 1/2 IN high.~~

## 2.6 UNDERGROUND MARKING TAPE

- A. Underground marking tape:
  1. 4 mil inert plastic film for underground use.
  2. Resistant to alkalis, acids and other destructive agents found in soil.
  3. Minimum tensile strength: 20 LBS per 3 IN width.
  4. Minimum elongation: 500 percent.
  5. Provide continuous printed message repeated every 16 to 36 IN warning of pipe buried below (e.g.: "CAUTION GAS LINE BURIED BELOW").
  6. Color code:
    - a. Yellow: Natural gas and fuel oil systems.
    - b. Blue: Water systems, domestic and fire.
    - c. Green: Sanitary sewer system.
  7. Reef Industries, Standard Terra Tape.

### ~~B. Underground detectable marking tape:~~

- ~~1. Lamination bond of 1 layer of aluminum foil between 2 layers of inert plastic film.~~
  - ~~a. Aluminum foil: Minimum 0.35 mils thick.~~

- ~~b. Inert plastic film: Minimum 4.3 mils thick.~~
- ~~2. Resistant to alkalis, acids and other destructive agents found in soil.~~
- ~~3. Minimum tensile strength: 63 LBS per 3 IN width.~~
- ~~4. Minimum elongation: 500 percent.~~
- ~~5. Provide continuous printed message repeated every 16 to 36 IN warning of pipe buried below (e.g.: "CAUTION GAS LINE BURIED BELOW").~~
- ~~6. Tape to be inductively locatable and conductively traceable using a standard pipe and cable device for minimum of 8 years after burial.~~
- ~~7. Color code:
 
  - ~~a. Yellow: Natural gas and fuel oil systems.~~
  - ~~b. Blue: Water systems, domestic and fire.~~
  - ~~c. Green: Sanitary sewer system.~~~~
- ~~8. Reef Industries, Detectable Terra Tape.~~

## **PART 3 - EXECUTION**

### **3.1 VALVE IDENTIFICATION**

- A. Identify all valves, with appropriate service designation and valve number designation on valve tags.
  - 1. Tagging of valves at unit heaters, fan coil units, air terminal unit reheat coils and plumbing fixture stops are not required.
- B. Install tags on valves using valve tag fasteners in manner for easy reading.
- C. Label medical gas valves in accordance with NFPA-99.
- D. Furnish electronic version of charts including valve identification number, location (room number, department) and purpose.
  - 1. Provide in file format and media as directed by Owner.
  - 2. Include with "Operation and Maintenance Manuals".

### **3.2 PIPE IDENTIFICATION**

- A. Fire-protection and sprinkler piping.
  - 1. Painting not required in non-finished areas.
- B. Identify piping systems with indicated lettering:
 

Drawing	Pipe Identification
Symbol	Lettering
HWR	Heating Hot Water Return
HWS	Heating Hot Water Supply
- C. Locate identification lettering as follows:
  - 1. Next to each valve and fitting, except on plumbing fixtures and equipment.
  - 2. At each branch or riser take off.
  - 3. At each passage through walls, floors and ceilings, both sides.
  - 4. At each pipe passage to underground.
  - 5. On horizontal pipe runs every 20 FT, at least once in each room and each story traversed by piping system.
  - 6. Identify piping contents, flow direction, supply and return.
  - 7. So it is readable from access panels and not obscured by other work.
  - 8. At least once in or above every room.

D. Size lettering, marker color fields, and arrows as follows:

Outside Diameter of Pipe or Pipe Covering IN	Length of Color Field (Markers) IN	Size of Letters and Arrows IN
3/4 to 1-1/4	8	1/2
1-1/2 to 2	8	3/4
2-1/2 to 6	12	1-1/4
8 to 10	24	2-1/2
Over 10	32	3-1/2

E. Pipe markers:

1. Install markers with tape color bands over each end of marker, extending around pipe and overlapping a minimum of 30 degrees.

F. Where supplementary color identification of medical gas piping is used, paint or label in accordance with gases and colors indicated in CGA Pamphlet C-9.

### ~~3.3 DUCTWORK IDENTIFICATION~~

~~A. Locate duct markers as follows:~~

- ~~1. At each branch or riser take-off.~~
- ~~2. Next to equipment.~~

~~B. Stencil ductwork or exterior surface of insulation.~~

### ~~3.4 EQUIPMENT IDENTIFICATION~~

~~A. Attach equipment nameplates in conspicuous location, directly on item of equipment or apparatus such as starters, pumps, fans, HVAC units and control panels.~~

- ~~1. Secure nameplates with self-tapping screws, or nuts and bolts.~~

~~B. For unsuitable surfaces, such as high temperature or lack of space, use copper or brass rings or chains to attach tags.~~

~~C. Identify devices located above ceilings with additional identification.~~

- ~~1. Use access panel markers (metal tack style) for acoustical tile ceilings, or engraved plastic style, 3/4 IN square, for mounting on panel door; or equipment nameplates.~~
- ~~2. Coordinate with Owner on identification method and color codes.~~
- ~~3. Provide markers on all removable ceilings and ceiling access panels to indicate locations of valves, dampers, smoke detectors, etc., and other mechanical items that may need servicing or adjustment. Glue marking tacks in place to prevent their falling out.~~

### ~~3.5 INSTALLATION OF UNDERGROUND MARKING TAPE~~

~~A. See Section 20 10 10.~~

### ~~3.6 CONTROL DIAGRAMS AND INSTRUCTIONS~~

~~A. Provide HVAC control and systems instructions and diagrams in wall-mounted frames.~~

- ~~1. Mount framed diagrams in conspicuous, easily accessible places in equipment rooms housing appropriate HVAC system.~~

~~B. Diagrams and instructions may be reduced in size provided they are easily readable and lettering is not smaller than "elite" type of standard typewriter.~~

**END OF SECTION**

## 1.5 EXTRA WORK

- A. Rock excavation will be paid for as extra work.
  - 1. Notify Construction Manager/Soils Engineer in time to record and/or measure quantity removed.
  - 2. Recorded quantity will be basis of payment.
  - 3. Include unit price on Proposal Form.

## PART 2 - PRODUCTS

### 2.1 ACCEPTABLE MANUFACTURERS

- A. Coal tar coating:
  - 1. Base:
    - a. Koppers Industries.
- B. Cleanouts:
  - 1. Base:
    - a. Wade.
- C. Coating and sealants:
  - 1. Base:
  - 2. Optional:
    - a. Koppers Industries.
    - b. Sonneborn Building Products.
- D. Other manufacturers desiring approval comply with Section 00 26 00.

### 2.2 PIPE AND FITTINGS

- A. Pipe and fittings – General:
  - 1. Meet or exceed applicable standards and Section 20 11 00.

***AD-1: Section 20 10 10; 05/19/2014: Revised paragraph 2.2, B.***

#### **B. Heating water piping, above grade (Through Lot 50 Parking Garage):**

- 1. Pre-insulated and jacketed conduit piping system per Section 20 11 00.
- C. Heating water piping, below grade:
  - 1. Pre-insulated and jacketed conduit piping system per Section 20 11 00.

***AD-1: Section 20 10 10; 05/19/2014: Deleted paragraph 2.3 in its entirety.***

### ~~2.3 VALVES AND VALVE BOXES~~

#### ~~A. Water valves, service: Complying with AWWA standards.~~

- ~~1. Butterfly valves: V-48.~~

### 2.4 BACKFILL MATERIAL

- A. Backfill material: As approved by Engineer.
  - 1. Free of rock cobbles, roots, sod or other organic matter, and frozen material.
  - 2. Moisture content at time of placement: 3 percent plus/minus of optimum moisture content.
    - a. As tested in accordance with ASTM D698.

**SECTION 20 11 00**  
**PIPE AND FITTINGS (Reissued AD-1)**

**PART 1 - GENERAL**

**1.1 SUMMARY**

- A. Furnish labor, materials, tools, equipment, and services for Pipe and Fittings, as indicated, in accordance with provisions of Contract Documents.
- B. Systems Included:
  - 1. Pressurized piping.
  - 2. Accessories:
    - a. Unions.
  - 3. Pre-insulated and jacketed piping systems.
- C. This specification lists a variety of piping that may be applicable to the project. Not all piping and fittings listed are applicable to the project, refer to appropriate spec sections for project applicability.
- D. Completely coordinate with work of other trades.

**1.2 QUALITY ASSURANCE**

- A. Pipe and fittings to be ASTM labeled for rating specified.
- B. Pipe and fittings to be marked with the collective trademark of the Cast Iron Soil Pipe Institute and be listed NSF International.
- C. Welder qualifications: Certified under requirements of ANSI/ASME-B31.1 Power Piping.
- D. **Grooved Piping Certification Training:**
  - 1. **The installing contractor shall be certified by the grooved coupling manufacturer for the installation of their product. A manufacturer's factory trained representative (direct employee) shall provide on-site certification training for the installing contractor's field personnel in the use of grooving tools, application of groove, and product installation.**
  - 2. **A field training program must be designed, developed, administered and evaluated in accordance to the ANSI/IACET Standard for Continuing Education and Training. (IACET-International Association for Continuing Education and Training)**
  - 3. **All installation professionals and pipe fitters must be able to provide proof of successful course completion upon request.**
- E. **Grooved Piping Inspection Service:**
  - 1. **A manufacturer's factory trained inspector (direct employee) shall visit the job site and review installation. The installing contractor shall remove and replace any improperly installed products.**
  - 2. **Upon completion of the manufacturer's inspection of the installation, they shall supply the owner with a full 30 year warranty. (Does not apply to fire protection piping. Standard warranty may be submitted for fire protection piping system.)**
  - 3. **All grooved components shall conform to local code approval and/or as listed by ANSI-B-31.1, B-31.3, B-31.9, ASME, UL/ULC, FM, IAPMO or BOCA.**
  - 4. **Grooved end product manufacturer to be ISO-9001 certified.**

- F. To assure uniformity and compatibility of piping components in grooved piping systems, all grooved products utilized shall be supplied by a single manufacturer. Grooving tools shall be supplied from the same manufacturer as the grooved components.**

### 1.3 SUBMITTALS

- A. Project Information:
1. Manufacturer of listed products.
  2. Pre-insulated conduit piping system test reports.
- B. Grooved joint couplings and fittings shall be shown on drawings and product submittals and shall be specifically identified with the applicable style or series number.**

## PART 2 - PRODUCTS

### 2.1 ACCEPTABLE MANUFACTURERS

- A. Fittings, mechanical groove-end and plain-end pipe:
1. Base:
    - a. Victaulic Company of America.
  2. Optional:
    - a. Anvil International, Inc.
    - ~~b. Grinnell.~~
- B. Pre-insulated and jacketed piping system:
1. Base:
    - a. Perma-Pipe.
  2. Optional:
    - a. Rovanco.
    - b. Thermacor Process.
    - c. Thermal Pipe Systems.
- C. Other manufacturers desiring approval comply with Section 01 60 00.

### 2.2 PIPE

- A. Black steel pipe:
1. Seamless or welded steel pipe, ASTM-A53, standard weight unless otherwise indicated.
  2. For fire sprinkler service:
    - a. The following Testing Standards and listed grades are acceptable:
      - 1) ASTM-A135, Grade B
      - 2) ASTM-A53, Grade B.
      - 3) ASTM- A795, Grade B.
    - b. Weight: Schedule-40 unless otherwise indicated.
- B. Copper pipe:
1. Seamless copper tubing, ASTM-B88, Type-K, Type-L, or Type-M as indicated.
  2. Joints:
    - a. Soldered: Use ASTM-B32, 95 percent tin, 5 percent antimony solder, or Silvabrite 100.
    - b. High temperature soldered: Use 1,000 degF solder.
    - c. Roll grooved.

### 2.3 FITTINGS AND COUPLINGS

- A. Steel pipe fittings:
1. **Socket welding fittings: ANSI/ASME-B16.11 and ASTM A234.**
  2. **Butt welding fittings: ANSI/ASME-B16.9, ANSI/ ASME-B16.25 and ASTM A105.**

3. **Grooved fittings: Square cut, ASTM-A53 steel or ASTM A536 ductile iron, or roll grooved, ASTM-A135. Factory grooved ends designed to accept Victaulic stab-on, standard or AGS couplings. (UL/FM approved Firelock grooved fittings and couplings are acceptable for use on fire protection systems.)**
  4. **Grooved mechanical couplings: ASTM F1476; two ductile iron housings, ASTM A536, synthetic rubber gasket, and plated steel bolts and nuts.**
    - a. **2" to 12": "Installation Ready" design suitable for hot water up to 250 deg F. Base: Victaulic Style 107H (rigid) and Style 177 (flexible).**
    - b. **14" and Larger: AGS couplings suitable for hot water up to 230 deg F. Base: Victaulic Style W07 (rigid) and Style W77 (flexible).**
  5. **Flanged fittings: ANSI/ASME-B16.5 and ASTM A105.**
  6. **Flange bolts: ASTM A193 Grade B7.**
  7. **Gaskets: Spiral wound metallic.**
- B. **Copper pipe fittings:**
1. **Wrought copper fittings: ANSI/ASME-B16.22.**
  2. **Cast brass fittings: ANSI-B16.18.**
  3. **Mechanical groove-end fittings: Factory roll grooved.**
  4. **Flared tubing fittings: Use only on annealed pipe.**
  5. **Cast flanged fittings: ANSI/ASME-B16.24, Class 150.**
- C. **Dielectric fittings:**
1. **No dielectric unions or water way fittings are allowed.**
- D. **Mechanical groove-end couplings and fittings:**
1. **Couplings:**
    - a. **Ductile iron, ASTM A47 or ductile iron, ASTM A536.**
    - b. **Gaskets:**
      - 1) **2" to 12": EPDM-HP Grade-EHP conforming to ASTM D2000 for water or dry air services to 250 degF for pipe 2-12.**
      - 2) **14" and Larger: EPDM Grade-E conforming to ASTM D2000 for water services up to 230 degF.**
    - c. **Gaskets on plastic piping: ASTM F477.**
    - d. **Bolts and nuts: ASTM A449 and A183.**
      - 1) **Heat treated plated carbon steel, track-head.**
      - 2) **Minimum tensile strength: 110,000 PSI.**
  2. **Fittings:**
    - a. **Ductile iron, ASTM-A536.**
    - b. **Steel: Wrought steel, ASTM A-234; Factory-fabricated, ASTM A-53.**
    - c. **Copper:**
      - 1) **ASME B16.22 and ASTM-B75, C12200; wrought copper.**
      - 2) **ASME B16.18 and ASTM-B584, CDA 844.**
      - 3) **Copper-tube dimensioned. (Flaring tube or fitting ends to accommodate alternate sized couplings is not allowed.)**
- E. **Unions.**
1. **Same type, pressure rating and material as piping.**
  2. **Flanges: Raised face type of same type, pressure rating and material as piping.**
  3. **Unions in copper pipe:**
    - a. **2 IN and smaller: Use wrought copper solder joint copper to copper unions.**
    - b. **2-1/2 IN and larger: Use brass flange unions.**
  4. **Dielectric unions: NOT PERMITTED.**

## 2.4 PRE-INSULATED AND JACKETED PIPING SYSTEM

- A. **Pre-insulated piping system:**
1. **System consists of factory insulated carrier-pipe sections.**
    - a. **Including:**

- 1) Inner pipe and fittings.
  - 2) Outer HDPE jacket.
  - 3) Insulation material.
  - 4) Seals.
2. Carrier pipe:
    - a. Hydronic and Plumbing piping 2 IN and less: Type L copper.
    - b. Hydronic and Plumbing piping 3 IN and greater: A53 ERW Grade B, Standard weight, schedule 40 black steel.
    - c. Carrier Pipe Insulation:
      - 1) Polyurethane Foam
        - a) K factor: 0.14.
        - b) 2 to 3 PCF
        - c) Closed cell content standard: 90-95 percent closed cell content, in conformance with ASTM C591.
      - 2) Thickness:
        - a) Below grade: 2 IN.
        - b) Above grade: 3 IN.
3. Outer casing jacket:
    - a. Material: HDPE.
    - b. Wall thickness:
      - 1) 12 inch pipe size and smaller: 125 mils.
      - 2) 14 inch to 24 inch pipe size: 150 mils.
      - 3) Pipe size above 24 inch: 175 mils.
  4. Field joints:
    - a. Service pipe: hydrostatically tested at 1.5 times the specified pressure of the system.
    - b. Straight joint sections:
    - c. Insulated using urethane foam; same thickness as carrier pipe insulation.
    - d. Jacket: HDPE split sleeve sealed with pressure sensitive, polyethylene backed, rubberized bitumen adhesive tape, 30 mils thick or heat shrink sleeve.
    - e. All joint closures and insulation shall occur at straight sections of pipe.
    - f. All insulation and jacketing materials shall be furnished by manufacturer.
  5. Moisture Barrier End seals:
    - a. Shall be factory applied, sealed to the jacket and carrier pipe.
    - b. Certified to have passed a 20 FT w.g. head pressure test.
  6. Basis of Design:
    - a. Perma-pipe XTRU-THERM

## **PART 3 - EXECUTION**

### **3.1 GENERAL**

- A. Comply with ANSI/ASME-B31.9 for pressure piping installations.
  1. Install piping without "bull-head" fittings.
- B. Flush out water piping systems with clean water prior to adding treatment.
- C. Flush out fuel oil piping with compressed air.
- D. In general, make connections to components in piping systems with 3-elbow swing joints to allow for movement.
  1. Movement includes but not limited to expansion, contraction, seismic, and equipment vibration isolation.

### **3.2 PIPING**

- A. Install piping parallel to building walls at such heights as not to obstruct portion of window, doorway, stairway, or passageway.

1. Where interference develops in field, offset or reroute piping as required to clear such interferences.
  2. Consult Drawings for exact location of pipe spaces, ceiling heights, door and window openings or other architectural details and report discrepancies to Architect, before installing piping.
- B. Pitch piping to drain:
1. Minimum pitch of 1 IN in 100 FT(except drainage piping).
  2. Make piping and equipment drainable.
  3. Accomplish pipe drainage using drain valves located on equipment and fixtures or separate drains.
  4. Drains: See Section 20 05 19.
- C. Factory cut and thread nipples from seamless stock.
1. Use nipples of same material as pipe with which they are used.
  2. Do not use close nipples except where such use is unavoidable.
  3. Use Schedule-80 seamless pipe for close nipples and nipples of pipes 3/8 IN or smaller.
- D. Provide backing and sleeves required in walls or floors for setting of fixtures or equipment.
- E. Where transition occurs from sweated fittings (as at connection to fixture supplies, etc.), provide rigid anchorage so that no strain will be placed upon tubing.

### 3.3 JOINTS

- A. Threaded joints:
1. Cut piping carefully, ream, thread and work into place without springing.
  2. Use a small amount of prepared pipe thread lubricant on outside threads only.
  3. Provide in accordance with ANSI/ASME-B1.20.1.
- B. In lieu of dielectric waterways, install valve at each piping joint and equipment connection between ferrous and non-ferrous materials. Valve shall be constructed with alloy containing silicon to inhibit electrolysis.
- C. Flanged joints:
1. Take care to ensure that there is no restraint on opposite end of pipe or fittings which would prevent uniform gasket compression or cause unnecessary stress in flanges.
  2. Keep one flange free to move in any direction while flange bolts are being tightened.
  3. Do not pack or assemble bell and spigot joints affected by flanged joints until such flanged joints have been tightened.
  4. Tighten bolts gradually and at a uniform rate, so that gasket compression is uniform over entire area of gasket.
- D. Mechanical joints:
1. Assemble in accordance with instructions and recommendations of pipe manufacturer.
  2. Clean joint surfaces and lubricate with soap solution or water soluble lubricant immediately before joint is assembled.
- 3. Groove-end and plain-end joints:**
- a. **Use mechanical joint system only with pipe meeting joint manufacturer's requirements.**
    - 1) **When joint manufacturer's pipe requirements exceed specified requirements, provide pipe that meets joint manufacturer's requirements.**
  - b. **Prepare pipe and install system in accordance with joint manufacturer's instructions and recommendations. All grooved couplings, fittings, valves, and specialties shall be the products of a single manufacturer. Grooving tools shall be of the same manufacturer as the grooved components.**
  - c. **The gasket style and elastomeric material (grade) shall be verified as suitable for the intended service as specified. Gaskets shall be molded and produced by the coupling manufacturer.**

- d. **Grooved end shall be clean and free from indentations, projections, and roll marks in the area from pipe end to groove for proper gasket sealing.**
- e. **A factory-trained field representative shall provide on-site training for contractor's field personnel in the proper use of grooving tools and installation of grooved piping products. Factory-trained representative shall periodically review the product installation. Contractor shall remove and replace any improperly installed products.**

### 3.4 UNIONS

- A. Provide a union between valves, at connection to each fixture, device or item of equipment, and elsewhere as required to facilitate installing, servicing, making up and disconnecting piping.
  - 1. Install each union to facilitate removal of parts, equipment or fixtures for inspection or cleaning.
  - 2. Install in a position which will permit device, fixture or part to be removed without disconnecting piping except unions.
- B. Install unions as directed by Fluid Controls Institute, (FCI).
  - 1. Grooved piping systems:
    - a. Grooved type couplings may serve as unions.
  - 2. Make connections between couplings and flanged equipment with slip-on flanges and a grooved nipple, or groove-to-flange adapter.
  - 3. Welded piping systems:
    - a. Where flanged end-service valves are used at equipment connections, flange unions will not be required.
    - b. Make connections to flanged valves and equipment using ANSI welding neck or slip on type welding flanges.
    - c. Flanged cast iron ells may be used for connections between pumps, strainers, check valves and other flanged equipment.
- C. In lieu of dielectric unions, install valve at each piping joint and equipment connection between ferrous and non-ferrous materials. Valve shall be constructed with alloy containing silicon to inhibit electrolysis.

### 3.5 PIPING EXPANSION

- A. Install piping to allow thermal expansion and contraction without injury to piping, equipment or structure.
  - 1. Use loops or expansion joints where necessary and where detailed.
  - 2. Provide pipe guides at loops as indicated.
- B. Where screwed piping is used for soil, waste or vent risers, or downspouts, use caulked joints or expansion joints at intervals to allow expansion movement.

### 3.6 WELDED STEEL PIPING

- A. Where welded piping is specified, make welds by oxy-acetylene or electric process in accordance with ANSI/AWS-D10.12 and ANSI/AWWA-C206.
  - 1. Welding rods: Grade recommended for purpose by manufacturer; each rod stamped with manufacturer's name and identification.
- B. Line welds:
  - 1. Single V-butt type.
  - 2. Mill or machine bevel pipe at 37.5 degrees to within 1/16 IN of inside wall, except that in field, limited amount of pipe may be flame beveled.
  - 3. Pipe with a wall thickness of 3/16 IN or less need not be beveled but may be welded by melting down into, and building up over abutting ends.
  - 4. Separate abutting ends of joints before welding to permit complete fusion to bottom without overlapping.
  - 5. Tack in 2 or more points to maintain alignment, and fusion weld.

- 6. Weld continuously around pipe.
- C. Make welds of sound weld metal, thoroughly fused into ends of pipe, and to bottom of vee.
  - 1. Build in excess of pipe wall to give reinforcement of 0.25 pipe wall thickness.
  - 2. Weld metal shall present a gradual increase in thickness from surface of pipe to center of weld.
  - 3. Minimum weld width: 2.5 times thickness of pipe wall.
- D. Use welding ells at turns in welded lines except where pipe bends are indicated or are required for flexibility.
- E. Mitered ells will not be permitted.
- F. Do not weld pipe couplings in place of welding fittings for branch connections.
- G. Weld-O-Lets and Thread-O-Lets:
  - 1. Scribe and cut openings in main pipes for welded branches accurately taking care to remove plug and cuttings from main pipe.
  - 2. Full weld fillet welds for full depth of fillet, with additional beads to form well rounded connection as recommended by Weld-O-Let manufacturer.
    - a. Partially filled fillets not acceptable.
- H. Cut openings into pipe for welded connections accurately to give carefully matched intersections.
- I. Make welded fittings of same material with same pressure and temperature rating as pipe with which they are used.
- J. Make flanged connections to control valves, pump suction, and specialties with ANSI standard welding neck flanges.
  - 1. Other flange connections may be made with slip-on flanges provided they are seal welded on inside.
- K. Fuse fillet welds for flanges or fittings into pipe and plate for minimum distance of 1.5 times pipe wall thickness and depth of weld of 1.25 times pipe wall thickness.

### **3.7 THREADED STEEL PIPING**

- A. Branch connections to screwed piping may be made with Weld-O-Lets or Thread-O-Lets.
- B. Do not weld pipe couplings in place of welding fittings for branch connections.

### **3.8 COPPER PIPING**

- A. Brazed (high temperature soldered) joints:
  - 1. Take care to avoid annealing of pipe material.
  - 2. For pipe sizes 2 IN and larger: Use a circular torch such as Circa Torch by Cedarberg Industries, for soldering joints.
- B. Use lead-free solder.
- C. T-drilling:
  - 1. Tapped pipe shall be least 1 IN diameter and branch shall be at least 2 pipe sizes smaller.
  - 2. Braze (high-temperature solder) joints.
  - 3. Branch pipe shall not protrude into main.

### **~~3.9 VITRIFIED CLAY PIPING~~**

- ~~A. Install in accordance with ASTM C12.~~
- ~~B. Lay pipe on undisturbed earth excavated to support bottom quadrant of pipe with bell holes cut out.~~
- ~~C. Bring over excavated trenches to grade with compacted granular fill.~~

- ~~D. Lay pipe with bell pointing upgrade, with ends abutting and true to line and grade, and smooth uniform invert.~~
- ~~E. Clean sockets before pipes are lowered into trenches.~~
- ~~F. Test pipe in sections as directed by Architect.~~
  - ~~1. Maximum allowable infiltration: 15 GAL/IN diameter/100 FT/day or 100 GAL/100FT/day.~~
  - ~~2. Repair visible leakage and leakage in excess of allowable.~~
- ~~G. Check each line with a light: indicate a good circle throughout length.~~

### ~~3.10 PVC PRESSURE AND SEWER PIPE~~

- ~~A. Before starting installation, insure factory installed gasket, bell recess and beveled spigot end are free of dirt.~~
- ~~B. Apply lubricant to exposed surface of gasket; then to surface of spigot up to stop mark including tapered end of spigot.~~
- ~~C. Assemble spigot to bell and insert; then push spigot into bell as far as stop mark either by hand or with a bar and block.~~
- ~~D. Install pipe in accordance with Uni-Bell UNI-B-5, Recommended Practice for Installation of Polyvinyl Chloride (PVC) Pipe.~~

### ~~3.11 GLASS PIPING~~

- ~~A. Install in accordance with manufacturer's recommendations and instructions.~~

### ~~3.12 PVC PIPING~~

- ~~A. Make pipe cuts only with miter box.~~
  - ~~1. Make cuts square and straight with pipe centerline.~~
  - ~~2. Use fine toothed hand wood saw with 14 or more points per inch.~~
  - ~~3. After cutting, slightly ream pipe inside and remove external burrs.~~
- ~~B. Pipe threading:~~
  - ~~1. Form standard tapered pipe thread using sharp dies with a negative rake angle of 5 degrees.~~
  - ~~2. Perform threading over inserted tapered wooden plugs to assure uniform deep threads.~~
  - ~~3. Dies must be sharp and clean.~~
  - ~~4. Assemble threaded joint using either graphite base compound or compound recommended by pipe manufacturer.~~
  - ~~5. Apply to male threads only and seat joint at slightly more than hand tightness.~~
  - ~~6. Wrench marks will not be allowed on either fitting or pipe.~~
- ~~C. Chemical welding:~~
  - ~~1. Perform in strict accordance with manufacturer's recommendations.~~
  - ~~2. Comply with ASTM D2855.~~
  - ~~3. Clean both pipe and fitting contact areas with recommended cleaner.~~
  - ~~4. Apply cement lightly to both pipe and fitting and slide fitting on to pipe with one continuous motion and at proper time.~~
  - ~~5. Rotate fitting lightly to distribute cement.~~
  - ~~6. Wipe off excess cement.~~
  - ~~7. Deliver cement for chemical welding to job site in sealed pint containers and keep covered at all times when not in use.~~
  - ~~8. Do not dilute, thin or alter cement.~~
  - ~~9. Use only cement recommended by pipe manufacturers.~~

### **3.13 POLYPROPYLENE PIPING**

- ~~A. Make thermal welded joints in accordance with manufacturer's recommendations and instructions.~~

### **3.14 PRE-INSULATED CONDUIT PIPING SYSTEM**

- ~~A. Pre-engineered systems shall be provided with all straight pipe and fittings factory pre-insulated and prefabricated to job dimensions.~~
- ~~1. Conduit test: pressure test for 2 hours at 15 psig. Repair any conduit leaks and retest prior to making joint closures.~~
  - ~~2. Carrier Pipe pressure test: 1.5 times normal system operating pressure.~~
- ~~B. Connect carrier pipe to steel pipe above ground with 150 PSI flat faced flanges.~~
- ~~1. Anchor steel pipe within 5 FT of flanges, avoid transmitting thrust, stress or torque to carrier piping.~~
- ~~C. Provide reaction anchorage at changes of direction.~~
- ~~1. Size and apply anchorages in accordance with manufacturer's recommendations.~~
  - ~~2. See Section 20 10 00.~~
- ~~D. Underground systems:~~
- ~~1. Trench depth: not less than 2 FT deeper than the top of the pipe.~~
  - ~~2. Trench width: not less than 18 IN wider than the combined O.D. of all piping systems.~~
  - ~~3. Backfill: a minimum thickness of 24 inches of compacted backfill placed over the top of the pipe.~~

### **3.15 PRE-INSULATED AND JACKETED PIPING SYSTEM**

- A. Pre-engineered systems shall be provided with all straight pipe and fittings factory pre-insulated and prefabricated to job dimensions.
- B. Connect carrier pipe to steel pipe above ground with 150 PSI flat faced flanges.
1. Anchor steel pipe within 5 FT of flanges, avoid transmitting thrust, stress or torque to carrier piping.
- C. Underground systems:
1. Trench depth: not less than 2 FT deeper than the top of the pipe.
  2. Trench width: not less than 18 IN wider than the combined O.D. of all piping systems.
  3. Trench bottom: minimum of 6 IN of manufacturer specified backfill material.
- D. Pipe pressure test: See specification 20 10 10 for field pressure test requirements.
- E. Backfill: a minimum thickness of 24 inches of compacted backfill placed over the top of the pipe.

**END OF SECTION**

**SECTION 23 21 13**  
HYDRONIC PIPING SYSTEMS (Reissued AD-1)

**PART 1 - GENERAL**

**1.1 SUMMARY**

- A. Furnish labor, materials, tools, equipment, and services for Hydronic Piping Systems, as indicated, in accordance with provisions of Contract Documents.
- B. Systems and Products Included:
  - 1. Systems:
    - a. Heating water piping.
  - 2. Products:
    - a. Air vents.
    - ~~b. Flow switch wells.~~
    - ~~c. Pressure and temperature test stations, combination.~~
    - ~~d. Strainers.~~
    - e. Valves.
    - ~~f. Water treatment system.~~
- C. Work installed but not furnished:
  - 1. Automatic valves: Furnished in Section 25 50 00.
    - a. Provide fittings and reducers required for installation of automatic valves.
  - 2. Electronic flow measurement devices: Furnished in Section 25 50 00.
- D. Completely coordinate with work of other trades.

**1.2 QUALITY ASSURANCE**

- A. Outside Utilities: Section 20 10 10.
- B. Piping standards: Section 20 11 00.
- C. Manual valve standards: Section 20 05 23 (for valves with "V" prefix).

**1.3 SUBMITTALS**

- A. Product Data:
  - 1. Air vents.
  - ~~2. Pressure and temperature test stations, combination.~~
  - ~~3. Strainers.~~
  - 4. Valves, manual.
  - ~~5. Water treatment system.~~
- B. Contract Closeout Information:
  - 1. Operating and maintenance data for items requiring operational instructions or periodic maintenance such as: air vents, constant flow control valves, pressure relief valves, triple duty valves, water flow measurement devices, water treatment system, glycol feed systems, etc.
  - 2. Field test reports.

**PART 2 - PRODUCTS**

**2.1 ACCEPTABLE MANUFACTURERS**

- A. High Capacity air vents, automatic:

1. Base:
    - a. Spirovent
  - ~~2. Optional:
 
    - a. Metraflex.
    - b. Armstrong International.
    - c. Hoffman Specialty.
    - d. Thrush.~~
- B. Low capacity air vents, automatic:
1. Base:
    - a. Spirovent
  - ~~2. Optional:
 
    - a. Armstrong International.
    - b. Hoffman Air & Filtration Systems.
    - c. Bell & Gossett, ITT.
    - d. Taco.
    - e. Thrush.~~
- C. Air vents, manual:
1. Base:
  2. Optional:
    - a. Crane Valves.
    - b. Jenkins.
    - c. Johnston.
    - d. OIC.
    - e. Powell.
- ~~D. Pressure/temperature test stations, combination (P/T plug).~~
- ~~1. Base:~~
  - ~~2. Optional:
 
    - a. Peterson Equipment Company (Pete's plug).
    - b. Sisco P/T Plugs & Flex Connectors.
    - c. Super Seal.
    - d. Fairfax.~~
- ~~E. Strainers, single-basket and tee:~~
- ~~1. Base:~~
  - ~~2. Optional:
 
    - a. Armstrong Machine Works.
    - b. Hoffman Specialty, ITT.
    - c. Keckley, OC.
    - d. Metraflex.
    - e. Mueller Steam Specialty.
    - f. Spence Engineering.
    - g. Spirax Sareo.
    - h. Tate.
    - i. Victaulic of America.~~
- ~~F. Water treatment system cleaning chemicals:~~
- ~~1. Base:
 
    - a. Oakite Products.~~
  - ~~2. Optional:
 
    - a. Miteo.
    - b. Diversy Water Technologies.~~
- G. Other manufacturers desiring approval comply with Section 00 26 00.

## 2.2 MATERIALS

### A. Pipe And Fittings

1. Pipe and fittings - General:
  - a. The following are not permitted:
    - 1) Plain end, pressure fit type fittings.
    - 2) Hole cut mechanical tee or saddle fittings.
2. Fittings: galvanized where galvanized piping is used.
3. Heating water piping, above grade, inside building:
  - a. Copper, type L, with soldered joints, and wrought copper or cast brass fittings.
  - b. Black steel, with welded joints.
    - 1) For 2-1/2 IN and larger: Use butt welding fittings.
    - 2) For 2 IN and less: Use socket welding fittings, 2000 PSI class, malleable or cast iron threaded fittings.
    - 3) Weld-o-let or thread-o-let type fittings may be used in lieu of tees for branch connections, provided main is one size larger than takeoff. Couplings or half couplings are not acceptable except for non-flow connections such as thermometers or gauges.
    - 4) BID ALTERNATE NO 1:
      - a) Grooved type couplings and fittings may be used for heating water piping.
4. Heating water piping, below grade:
  - a. Pre-insulated and jacketed conduit piping system per Section 20 11 00.
5. Make-up water piping:
  - a. Same as system served.
6. Water treatment system piping:
  - a. Same as system served.

#### B. AIR VENTS

1. High Capacity, automatic:
  - a. 300 PSI rated test pressure, minimum.
  - b. Maximum working pressure: 150 PSIG.
  - c. Maximum temperature: 212 degF.
  - d. Body and cover material: Cast iron, ASTM-A126, Class B.
  - e. Seat material: Stainless steel-T303, ASTM-A276 or Viton.
  - f. Float and float arm material: Stainless steel-T304, ASTM-A240.
2. Low Capacity, automatic:
  - a. 150 PSI rated, minimum.
  - b. Maximum working pressure: 100 PSIG.
  - c. Maximum temperature: 212 degF.
  - d. Cast bronze, chrome plated, body with renewable valve and seat.
  - e. Synthetic rubber disc.

#### C. ~~Flow Switch Wells~~

##### ~~1. Flow switch wells:~~

- ~~a. Install 1 IN thread o-let for flow switch installation.~~
- ~~b. Provide 1 IN nipple and cap.~~

#### D. ~~Pressure And Temperature Test Stations, Combination~~

##### ~~1. Pressure/temperature test station, combination:~~

- ~~a. Station to receive either a 1/8 IN OD temperature or pressure probe.~~
- ~~b. Fitting: Solid brass, 1/4 IN NPT, with 2 valve cores of neoprene (maximum 200 degF at 500 PSI) or Nordel (maximum 275 degF at 500 PSI).~~
- ~~c. Provide extension at locations with pipe insulation. Extension length shall match or exceed insulation thickness.~~
- ~~d. Provide with color coded and marked cap with gasket, rated at 1000 PSI at 140 degF.~~

2. ~~Pressure and temperature test kit:~~
  - a. ~~Range: 0-100 PSI, 0-230 FT WG.~~
  - b. ~~1/8 IN OD probe and 5 IN stem pocket testing thermometers.~~
    - 1) ~~Provide \_\_\_ for chilled water: 25-125 degF.~~
    - 2) ~~Provide \_\_\_ 50-500 degF for hot water.~~
  - c. ~~No. 500 gauge adapter with 1/8 IN OD probe.~~
  - d. ~~Protective carrying case.~~

**E. ~~Strainers~~**

1. ~~Strainers, single-basket type.~~
  - a. ~~Screwed or flanged.~~
  - b. ~~Body: Cast iron, flanged ends, bolted access cover.~~
  - c. ~~Coating: Rust inhibiting.~~
  - d. ~~Working pressure, non shock: 150 PSIG.~~
  - e. ~~Screens: Bronze, monel or stainless steel.~~
    - 1) ~~2 IN and less: 3/64 IN perforations.~~
    - 2) ~~2-1/2 IN and larger: 1/8 IN perforations.~~
2. ~~Strainer, tee-pattern type.~~
  - a. ~~Grooved ends.~~
  - b. ~~Body: One piece ductile iron casting conforming to ASTM A536 or malleable iron conforming to ASTM A47.~~
  - c. ~~Coating: Rust inhibiting.~~
  - d. ~~Working pressure rating: 300 PSI.~~
  - e. ~~Basket screen: 304 stainless steel 0.041 IN wire in a woven No.6 mesh wire screen with 0.126 IN opening.~~
  - f. ~~Vertical down flow or horizontal flow.~~
  - g. ~~Cleaning access through blank end cap.~~
3. ~~Strainers, wye:~~
  - a. ~~See Section 20-05-19, Piping Specialties.~~

**F. Valves**

1. ~~Manual valves:~~
  - a. ~~Angle valves:~~
    - 1) ~~2 IN and smaller: V-17.~~
    - 2) ~~2-1/2 IN and larger: V-18.~~
  - b. ~~Balancing valves:~~
    - 1) ~~2 IN and smaller: V-64.~~
    - 2) ~~2-1/2 IN to 12 IN: V-65.~~
    - 3) ~~8 IN and larger:~~
      - a) ~~Plug valve: V-37 with memory stop.~~
      - b) ~~Provide venturi waterflow measuring device.~~
    - 4) ~~Ball type balancing valves/circuit setters shall not be used.~~
  - c. ~~Isolation valves (Ball valves):~~
    - 1) ~~2 IN and smaller: V-13 or V-14.~~
  - d. ~~Isolation valves (Butterfly valves):~~
    - 1) ~~2 IN and smaller: not used.~~
    - 2) ~~2-1/2 IN and larger: V-35.~~
  - e. ~~Check valves, other:~~
    - 1) ~~2 IN and smaller: V-25.~~
    - 2) ~~2-1/2 IN and larger: V-28 or V-29.~~
  - f. ~~Globe valves:~~
    - 1) ~~2 IN and smaller: V-6 or V-7.~~
    - 2) ~~2-1/2 IN and larger: V-8.~~
  - g. ~~Plug valves:~~
    - 1) ~~2 IN and smaller: V-36.~~
    - 2) ~~2-1/2 IN and larger: V-37.~~

## ~~2.3 WATER TREATMENT SYSTEM~~

### ~~A. Water treatment system cleaning chemicals:~~

- ~~1. Alkaline:
  - a. Oakite 62, 162, 24, 77.~~
- ~~2. Acid:
  - a. Oakite 32.~~

## **PART 3 - EXECUTION**

### **3.1 GENERAL**

- A. Excavation and backfilling: Section 20 10 10.
- B. Reaction anchorage: Section 20 10 10.
- C. Piping more than 5 FT outside building: Section 20 10 10.
- D. Install in accordance with Section 20 11 00 and Section 20 05 00.
- E. Connect equipment.

### **3.2 PIPE AND FITTINGS**

- A. Do not insulate or conceal piping until testing is completed.

### **3.3 AIR VENTS**

- A. Air vents, automatic:
  1. Provide shut off valve ahead of vent.
  2. Provide copper relief line from valve to drain or drip pan.
  3. Provide at locations indicated on equipment and piping schematic drawings.
- B. Air vents, manual:
  1. Vents shall prevent air binding in systems.
  2. Vent valves:
    - a. Provide at trapped high points of closed cooling and heating piping systems.
    - b. Provide at coil headers in air handling units unless an automatic air vent is indicated at that location on equipment or piping schematic drawings.

### ~~3.4 FLOW SWITCH WELLS~~

#### ~~A. Provide flow switch wells at following locations:~~

- ~~1. Condenser water supply line to each chiller.~~
- ~~2. Chilled water return line to each chiller.~~

### ~~3.5 PRESSURE AND TEMPERATURE TEST STATIONS, COMBINATION~~

#### ~~A. Provide at locations indicated on equipment and piping schematic drawings.~~

### ~~3.6 STRAINERS~~

- ~~A. Provide full line size strainers ahead of control valves (motor operated), regulating valves, pumps, and as indicated.~~
- ~~B. Provide strainer types as indicated:
  1. Heating water: Single basket, tee, or wye type.~~
- ~~C. Connections to suit piping.~~
- ~~D. Provide blow down valves:
  1. Strainers 6 IN and larger: 1 1/2 IN blow down valve.
    - a. Pipe blow down to drain.
  2. Strainers 2 to 5 IN: 1 IN blow down valve with 3/4 IN hose end connection.~~

- ~~3. Strainers 1-1/2 IN and smaller: 1/2 IN blow-down valve with 3/4 IN hose end connection.~~

### ~~3.7 VALVES~~

- ~~A. Heating and cooling pipe risers:
  1. Provide isolation valves at main feed points to risers.
  2. Provide isolation valves at branch take-offs from risers.~~
- ~~B. Install pressure relief valves on heat exchangers' piping between exchanger and isolation valves.~~
- ~~C. Provide drain piping at pressure relief valves and valves with test levers:
  1. Extend piping to within 6 IN of floor.~~
- ~~D. Provide system drains: See Section 20-05-19.~~
- ~~E. Provide 3-valve manifold for each differential pressure sensor.
  1. Coordinate locations and quantities of sensors with Controls Contractor.~~

### ~~3.8 VIBRATION ISOLATION~~

- ~~A. Vibration Isolation: Section 20-05-50.~~

### 3.9 TESTING

- A. Test heating and cooling piping upon completion of a section or of entire system.
  1. Test hydrostatically to pressure not less than 50 percent in excess of maximum pressure to which pipe will ordinarily be subjected, but in no case less than 150 PSI.
  2. Repair or replace leaks or defective pipe disclosed by tests.
  3. Repeat tests until piping indicates tight.

### 3.10 CLEANING OF CHILLED AND HEATING WATER SYSTEMS

- A. The cleaning of the heating water system will be completed by the contractor of the Central Utility Plant Project. Provide line size cross tie between supply and return piping at end of system as indicated on drawings. Coordinate cleaning and flushing of system with the CUP contractor and UNMC.
- ~~B. Do not valve in or operate system pumps until after system has been cleaned.~~
- ~~C. At system completion, make temporary connection to domestic water system, and flush system until clear water is visible from drain connection.
  1. Drain system after flushing.~~
- ~~D. At project completion, clean systems:
  1. Thoroughly flush system with a recommended hot solution (160-180 degF) of alkaline cleaning chemical to remove oil and grease that may be present.
    - a. Thorough flushing includes eliminating air from system.
    - b. Drain systems, and rinse completely with clean water.
    - c. Measure and record volume of each system for purpose of chemical treatment.
  2. Add water and acid solution, and circulate through systems as recommended by manufacturer to remove rust and scale.
    - a. Circulate solution through systems at a minimum velocity of 10 FPS.
    - b. Drain systems, and rinse completely with clean water.
      - 1) Rinse system at a minimum velocity of 10 FPS.
  3. Check drain water for pH level.
  4. If drain water is acidic, neutralize system by thoroughly reflushing with alkaline type material as indicated above.~~
- ~~E. After cleaning is complete, and just before start-up, clean strainers.~~

**3.11 START UP**

- A. After cleaning is complete, and water pH is acceptable to manufacturer of water treatment chemicals, add manufacturer recommended amount of chemicals to systems.**
- B. Provide monthly testing for the first six months after start up to verify that the correct chemical concentrations are present in each system.**

**END OF SECTION**

PROJECT FOR  
**UNIVERSITY  
 NEBRASKA  
 MEDICAL CENTER**  
 CAMPUS SITE  
 UTILITY  
 IMPROVEMENTS

UNMC PROJECT:  
 P-14037



MARK	DATE	DESCRIPTION
	05/19/2014	ADDENDUM NO. 1
	05/02/2014	CONSTRUCTION DOCUMENTS
PROJECT NUMBER 099967 / 217523		
ORIGINAL ISSUE 05/02/2014		
PROJECT MANAGER	ANDREW YOSTEN	
PROJECT DESIGNER	LARRY LOFTUS	
PROJECT ARCHITECT	LARRY LOFTUS	
LANDSCAPE ARCHITECT	BRAD SWERCZEK	
CIVIL ENGINEER	MIKE KUHSE	
STRUCTURAL ENGINEER	ANDREW YOSTEN	
MECHANICAL ENGINEER	TIM KOCH	
ELECTRICAL ENGINEER	LARRY LOFTUS	
INTERIOR DESIGNER	LARRY LOFTUS	
EQUIPMENT PLANNER	LARRY LOFTUS	
DRAWN BY	BRAD SWERCZEK	



Site Plans / Site Details

SCALE: As Noted

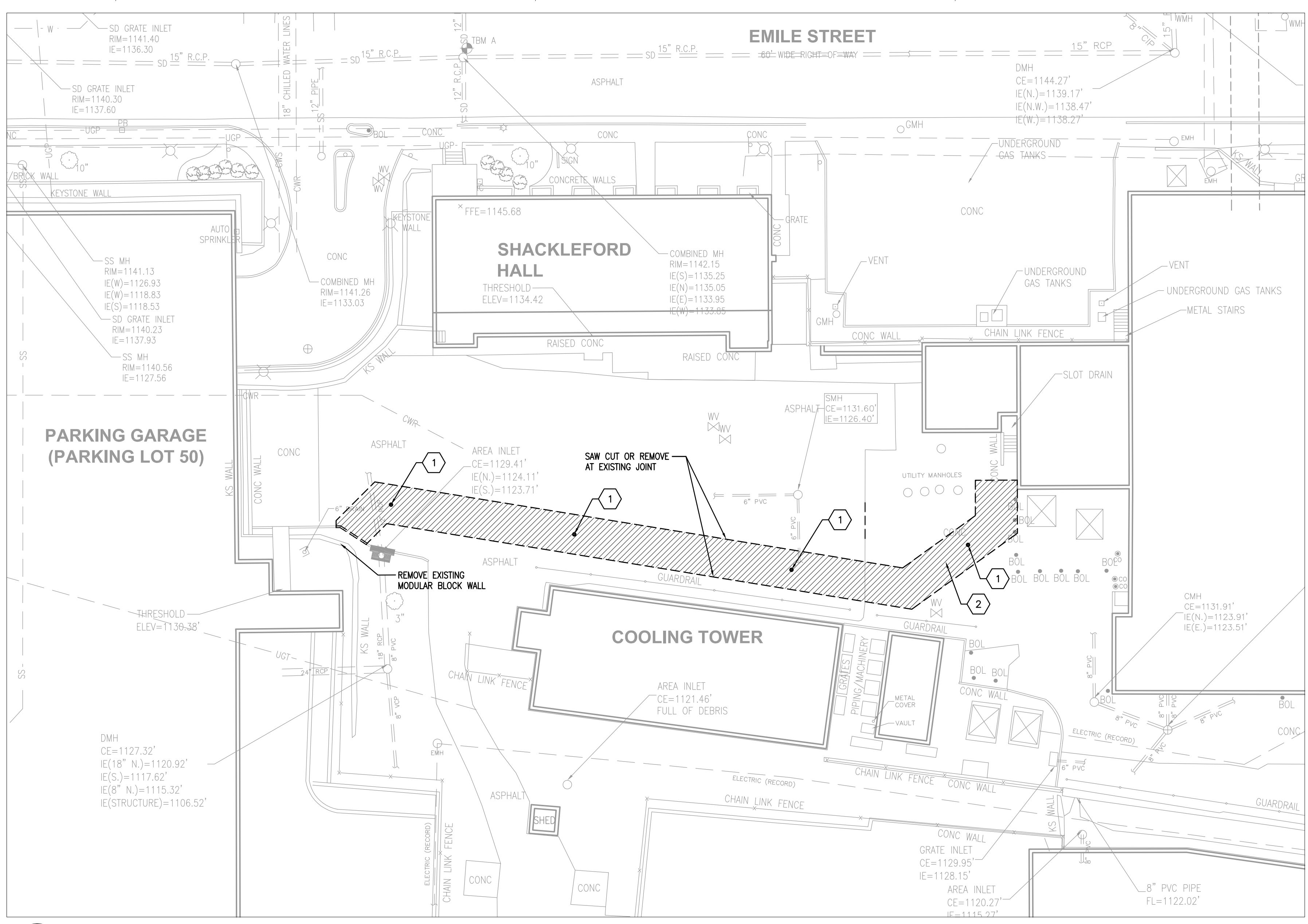

**C3 SITE DEMOLITION PLAN**  
 1"=20'-0"

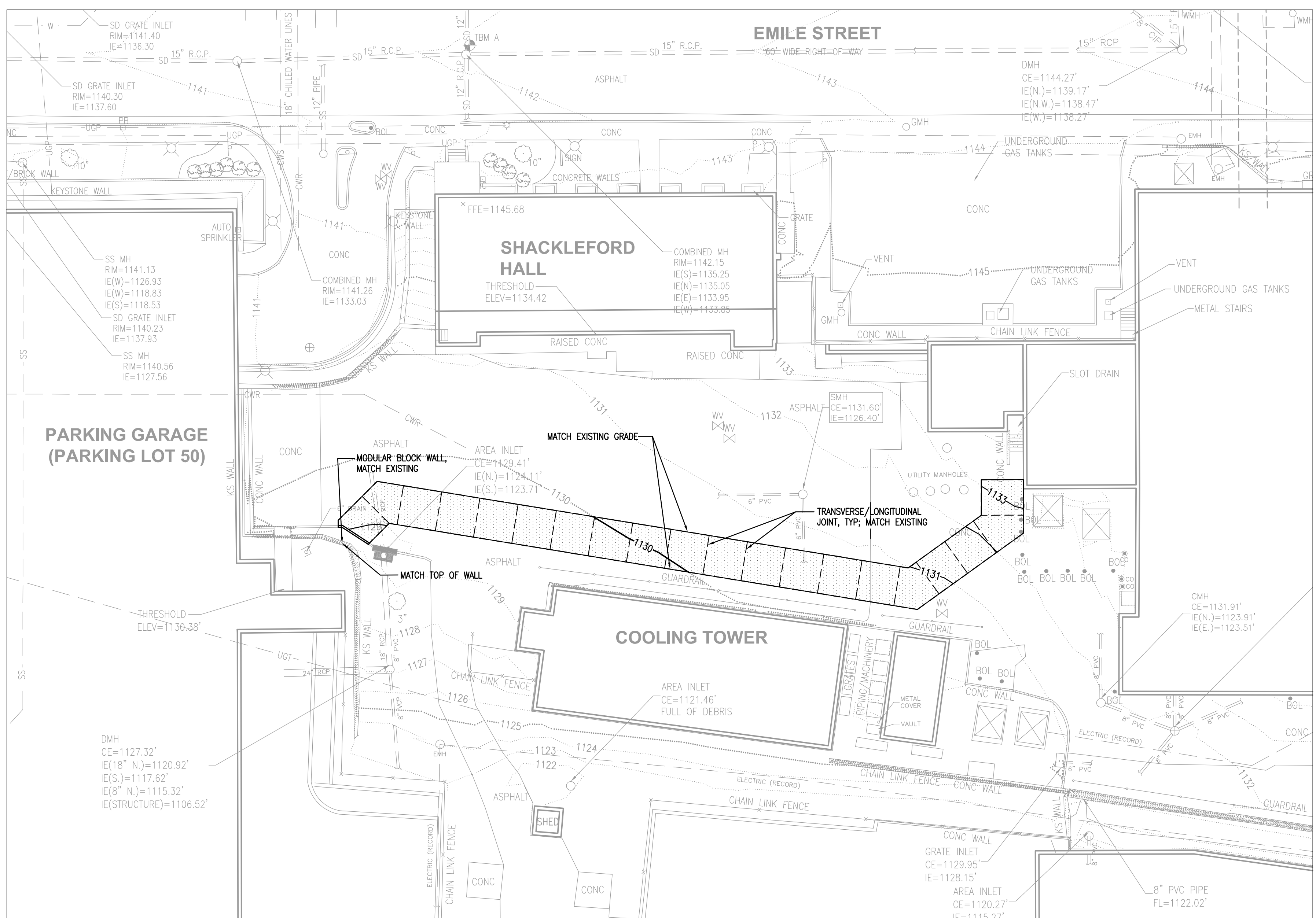

**A3 SITE PLAN**  
 1"=20'-0"

- LEGEND**
- × 977.41 EXISTING SPOT GRADES
  - 977 EXISTING GRADE CONTOUR
  - EXISTING CURB TO REMAIN
  - EXISTING LIGHTPOLE
  - EXISTING STREET LIGHT
  - EXISTING SIGNAGE
  - EXISTING WATER LINE WITH VALVE AND MANHOLE
  - SD EXISTING STORM DRAIN WITH MANHOLE
  - SS EXISTING SANITARY SEWER WITH MANHOLE
  - STM EXISTING STEAM LINE
  - COND EXISTING CONDENSATION LINE
  - CWR EXISTING CHILLED WATER RETURN LINE
  - CWS EXISTING CHILLED WATER SUPPLY LINE
  - WV EXISTING WATER LINE WITH VALVE
  - OHP EXISTING OVERHEAD POWER LINE
  - UGP EXISTING UNDERGROUND POWER LINE
  - UGT EXISTING UNDERGROUND TELEPHONE LINE
  - GVL EXISTING GAS LINE WITH VALVE
  - — PROPERTY LINE
  - EXISTING TREE TO REMAIN
- LOC-- LIMITS OF CONSTRUCTION**
- EXISTING CURB TO BE REMOVED
  - EXISTING TREE TO BE REMOVED
  - EXISTING PAVEMENT TO BE REMOVED
  - CONCRETE VEHICULAR PAVING
  - CONCRETE CURB

**DRAWING SPECIFICATIONS:**

1. CONSTRUCTION MINIMUM STANDARDS: CITY OF OMAHA, DEPARTMENT OF PUBLIC WORKS, "STANDARD SPECIFICATIONS FOR PUBLIC WORKS CONSTRUCTION," 15 OCTOBER 2012, 3RD EDITIONS, AS AMENDED DATE.
2. PROTECT EXISTING IMPROVEMENTS ADJACENT TO WORK AND ADJOINING PROPERTIES. CONTRACTOR RESPONSIBLE FOR REPAIR OR REPLACEMENT OF ANY DAMAGES CAUSED BY CONSTRUCTION ACTIVITIES.
3. CONTRACTOR TO REMOVE DEBRIS OR UNSUITABLE FILL ENCOUNTERED ON SITE. IF SIGNIFICANT AMOUNT OF DEPTH OF DEBRIS FOUND ON SITE, CONTRACTOR TO CONTACT A GEOTECHNICAL ENGINEER FOR RECOMMENDATIONS.
4. CONTRACTOR TO REMOVE ALL EXISTING SITE IMPROVEMENTS IDENTIFIED ON PLAN AND AS NEEDED TO COMPLETE CONSTRUCTION. REMOVE ALL WASTE MATERIALS FROM SITE. TOTALLY GRUB ALL AREAS.
5. LAYOUT WORK BY SURVEYOR OR CIVIL ENGINEER REGISTERED IN THE STATE OF NEBRASKA.
6. COMPACT SUBGRADE UNDER ALL PAVED AREAS AND ALL UTILITY TRENCH TO 98% STANDARD PROCTOR, ASTM-D698; COMPACT ALL OTHER AREAS TO 95% MAXIMUM DRY DENSITY.
7. FILL MATERIAL: LOW PLASTICITY, COHESIVE MATERIAL FREE OF ORGANIC MATERIAL OR COBBLES LARGER THAN 1" IN ANY DIMENSION. PLACE MATERIAL WITHIN 2% BELOW TO 3% ABOVE OPTIMUM MOISTURE CONTENT. PLACE FILL MATERIAL IN LIFTS, MAXIMUM 8" LOOSE THICKNESS.
8. PLACE 6" MINIMUM COMPACTED DEPTH TOPSOIL IN ALL SOD AND PLANTING BEDS. TILL 3" ORGANIC COMPOST TO MINIMUM DEPTH OF 8" IN ALL PLANTING BEDS.
9. PROVIDE SOIL EROSION AND SEDIMENT CONTROL BMPs PER CITY OF OMAHA EROSION AND SEDIMENT CONTROL MANUAL.
10. CONCRETE PAVING:
  - a. 1"=4,000 PSI
  - b. 4 INCH MAXIMUM SLUMP
  - c. 5 - 7 PERCENT AIR ENTRAINMENT
  - d. 3/4 INCH MAXIMUM AGGREGATE SIZE
  - e. 30 PERCENT COARSE AGGREGATE, 70 PERCENT FINE AGGREGATE
  - f. PORTLAND CEMENT, ASTM C150, TYPE 1, 580 LBS/CY.
    - 1) CEMENT COLOR: NATURAL GRAY
  - g. CURE CONCRETE AND SEAL JOINTS PER CITY SPECIFICATIONS
  - h. ALL CONCRETE TO BE FINISHED WITH A MEDIUM BROOM FINISH PERPENDICULAR TO PRIMARY DIRECTION OF TRAVEL.
  - i. CONCRETE WALK PAVING 5" THICK
  - j. CONCRETE VEHICULAR PAVING 9" THICK.
11. ALL DIMENSIONS ARE TO THE BACK OF CURB UNLESS NOTED OTHERWISE.
12. ALL CURVES TO BE SMOOTH AND NOT SEGMENTED.
13. PROTECT EXISTING IRRIGATION SYSTEM TO REMAIN. MODIFY EXISTING SYSTEM IMPACTED BY WORK TO MAINTAIN IRRIGATION TO AREAS NOT IMPACTED BY CONSTRUCTION ACTIVITIES.
14. CONTRACTOR TO RESTORE IRRIGATION SYSTEM TO ORIGINAL EXISTING CONDITION. MATCH EXISTING MANUFACTURER AND ORIGINAL EQUIPMENT.
15. SOD ALL TURF AREAS IMPACTED BY CONSTRUCTION ACTIVITIES, MATCH EXISTING TURF TYPE.
16. RESTORE PLANTING BEDS IMPACTED BY CONSTRUCTION ACTIVITIES TO ORIGINAL CONDITION. MATCH EXISTING PLANT VARIETIES AND SIZES.
17. ONE YEAR SHRUB, PERENNIAL, SOD, AND IRRIGATION WARRANTY. 2 YEAR TREE WARRANTY FROM DATE OF FINAL ACCEPTANCE. REMOVE AND REPLACE IMPAIRED, DEAD OR DYING PLANTS DURING WARRANTY PERIOD. OWNER TO PROVIDE WATER FOR PLANTING AND MAINTENANCE PERIOD.
18. SOILS WITH EXCESS CONTAMINATION SHALL BE REMOVED AND DISPOSED OF AT AN APPROVED LANDFILL. GRANULAR FILL SHALL BE USED TO REPAIR EXCESS CONTAMINATION.
19. THE CONTRACTOR WILL BE RESPONSIBLE FOR REMOVAL AND DISPOSAL OF NORMAL CONSTRUCTION EXCESS SOILS AND DEBRIS. IF CONTAMINATED SOILS ARE ENCOUNTERED RESULTING IN EXCESS CONTAMINATED SOILS, THE CONTRACTOR WILL BE RESPONSIBLE TO STOCKPILE AND COVER WITH PLASTIC (PROTECT FROM THE WEATHER) ALL EXCESS CONTAMINATED SOILS FOR DISPOSAL BY THE OWNER. FOLLOWING OWNER TESTING, THE CONTRACTOR WILL BE RESPONSIBLE FOR LOADING THE EXCESS CONTAMINATED SOILS ONTO OWNER SUPPLIED TRUCKS FOR OWNER SUPPLIED DISPOSAL.

**SHEET KEYNOTES:**

- 1) CONTRACTOR SHALL HAVE SOIL SAMPLES TESTED AT THE INDICATED LOCATIONS FOR CONTAMINATION. IF SOIL CONTAMINATION IS PRESENT, CONTRACTOR TO REMOVE AND DISPOSE OF SOIL PER ALL FEDERAL AND STATE REGULATIONS. COORDINATE REMOVAL OF ANY SOILS WITH UNIVERSITY OF NEBRASKA MEDICAL CENTER.
- 2) CONTRACTOR SHALL LOCATE ALL UTILITIES WITHIN SCOPE OF WORK PRIOR TO STARTING ANY WORK. COORDINATE UTILITY LOCATION BOUNDARIES WITH UNIVERSITY OF NEBRASKA MEDICAL CENTER.

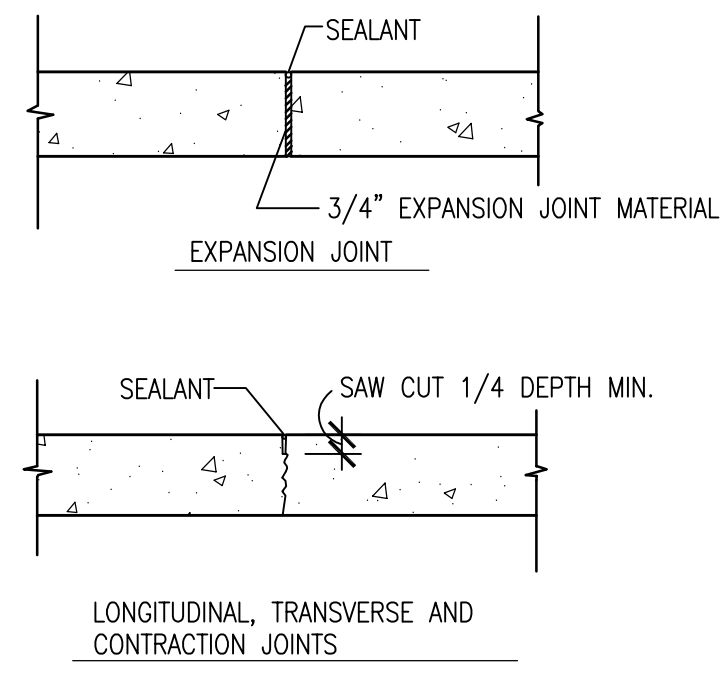

**B3 TYPICAL PAVING JOINTS**  
 NO SCALE

**EXISTING SURVEYOR INFORMATION**

EXISTING SITE SURVEY INFORMATION FURNISHED BY UNIVERSITY OF NEBRASKA MEDICAL CENTER AND PREPARED BY EHRHART GRIFFIN & ASSOCIATES, DATED MARCH 19, 2012. SURVEY UPDATED BY EHRHART GRIFFIN & ASSOCIATE, DATED AUGUST 13, 2012.

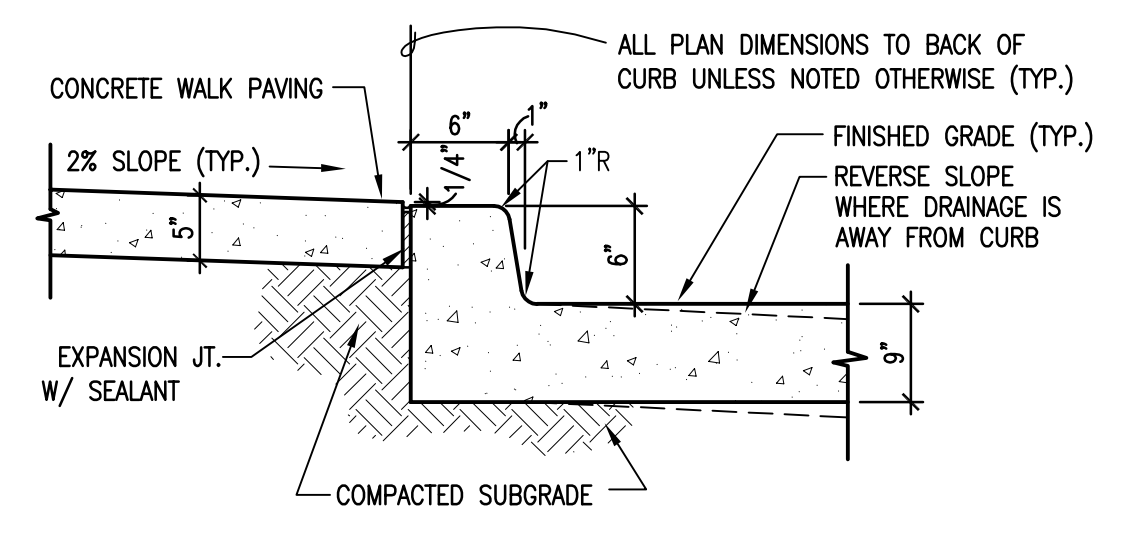

**A2 CONCRETE WALK PAVING/  
 CONCRETE VEHICULAR PAVING**  
 NO SCALE

**A3 SITE PLAN**  
 1"=20'-0"

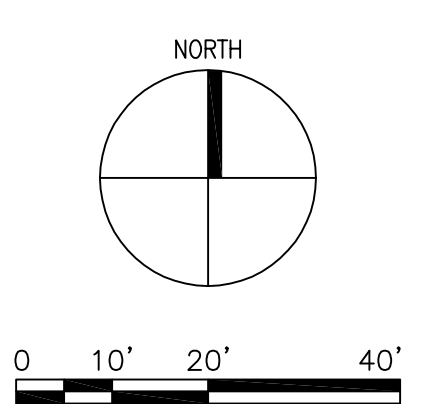

PROJECT FOR

UNIVERSITY  
NEBRASKA  
MEDICAL CENTER

CAMPUS SITE  
UTILITY  
IMPROVEMENTS

UNMC PROJECT:  
P-14037

UNIVERSITY OF  
**Nebraska**  
Medical Center

MARK	DATE	DESCRIPTION
1	05-19-2014	ADDENDUM #1
	05-02-2014	CONSTRUCTION DOCUMENTS
<b>ORIGINAL ISSUE</b>		
PROJECT NUMBER	09967 / 217553	
PROJECT MANAGER	ANDREW YOSTEN	
PROJECT DESIGNER	LARRY LOFTUS	
PROJECT ARCHITECT	LARRY LOFTUS	
LANDSCAPE ARCHITECT	BRAD SWIERCZEK	
CIVIL ENGINEER		
STRUCTURAL ENGINEER	MIKE KUHSE	
MECHANICAL ENGINEER	ANDREW YOSTEN	
ELECTRICAL ENGINEER	TIM KOCH	
INTERIOR DESIGNER		
EQUIPMENT PLANNER		
DRAWN BY	GREG ALDRICH	



PIPE SUPPORT  
SECTIONS AND  
DETAILS

SCALE: As Indicated

**S-501**

CONSTRUCTION DOCUMENTS

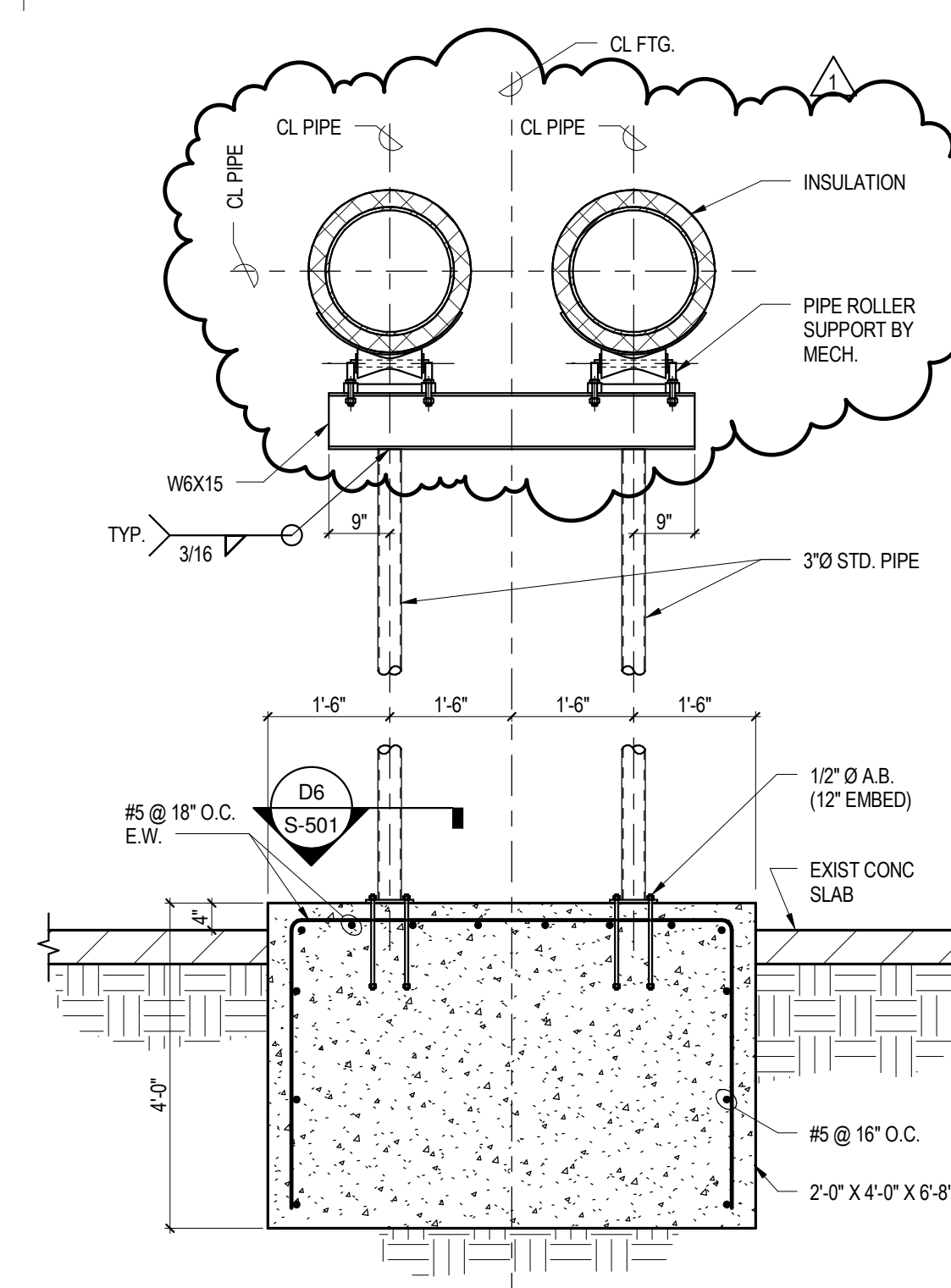

**D5** SECTION  
1/2" = 1'-0"

**D6** BASE PLATE DETAIL  
1" = 1'-0"

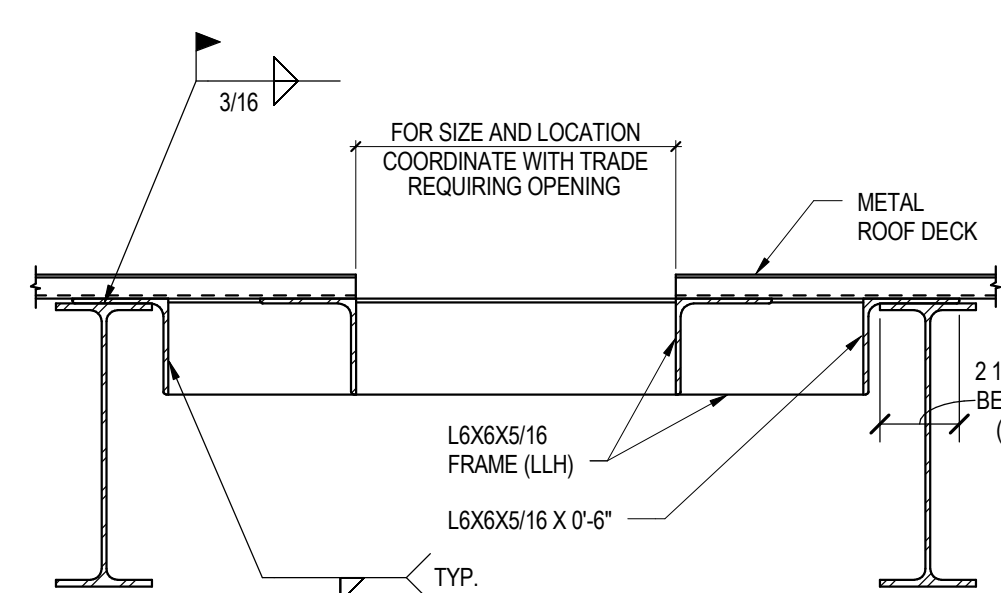

**C3** TYPICAL FRAMING AT OPENING  
1" = 1'-0"

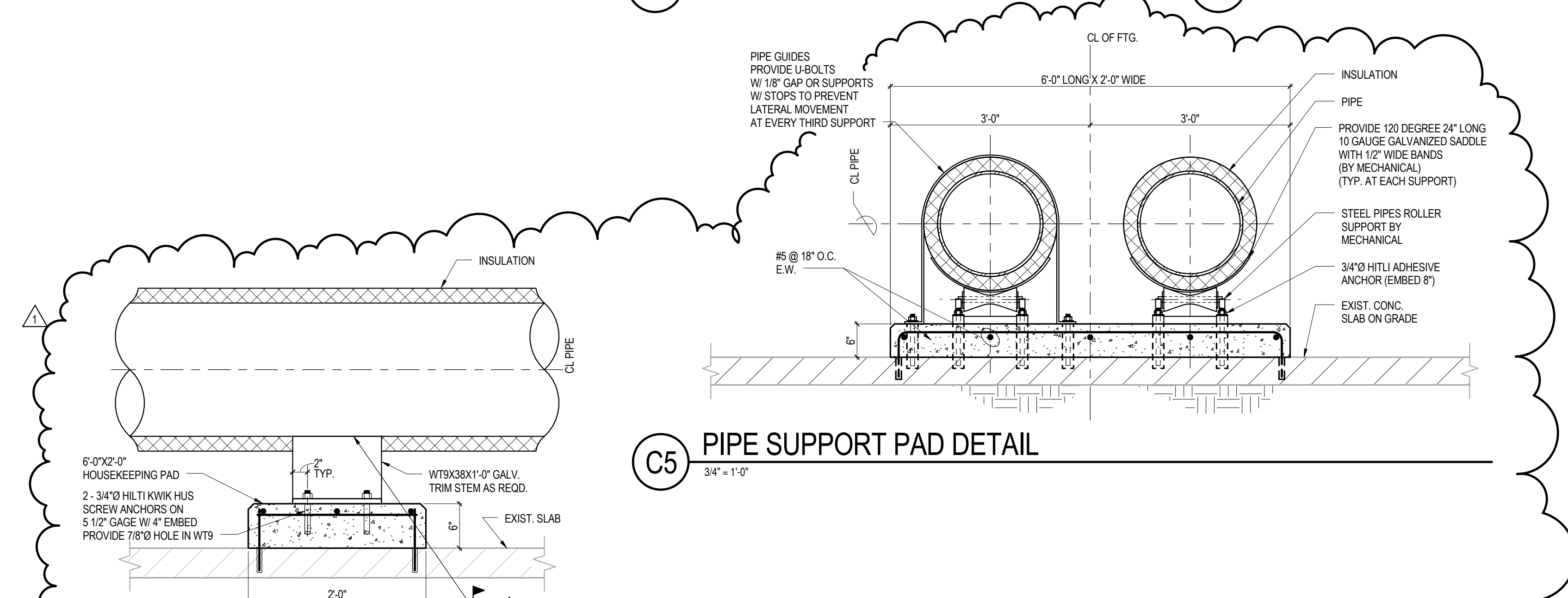

**C4** PIPE ANCHOR SUPPORT  
1" = 1'-0"

**C5** PIPE SUPPORT PAD DETAIL  
3/4" = 1'-0"

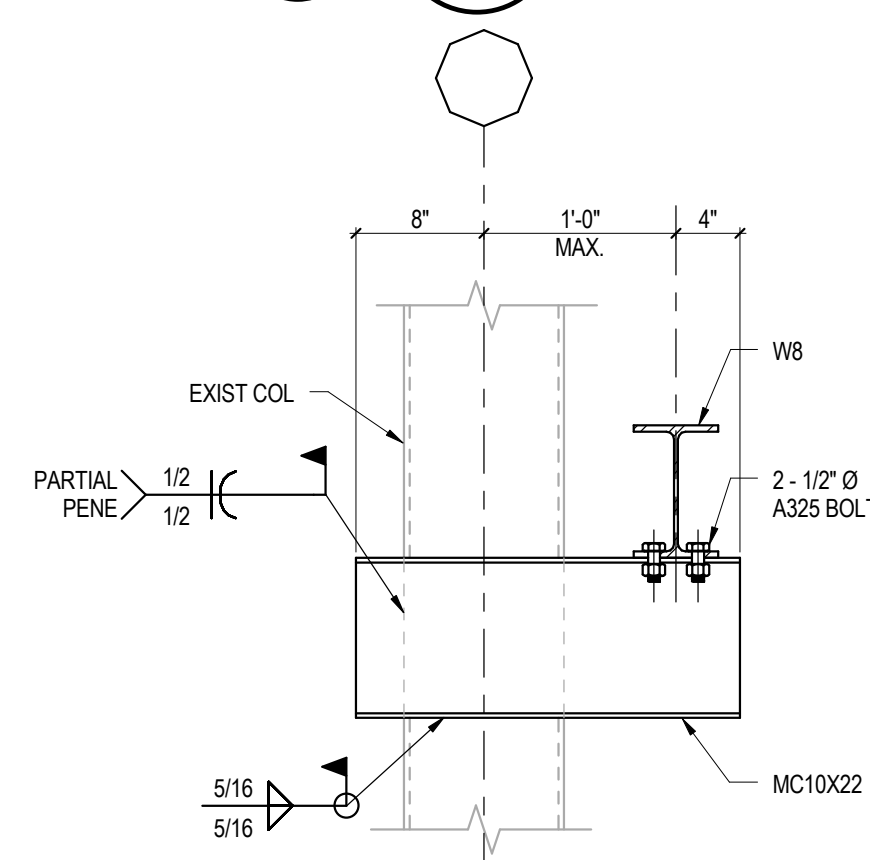

**B4** DETAIL  
1" = 1'-0"

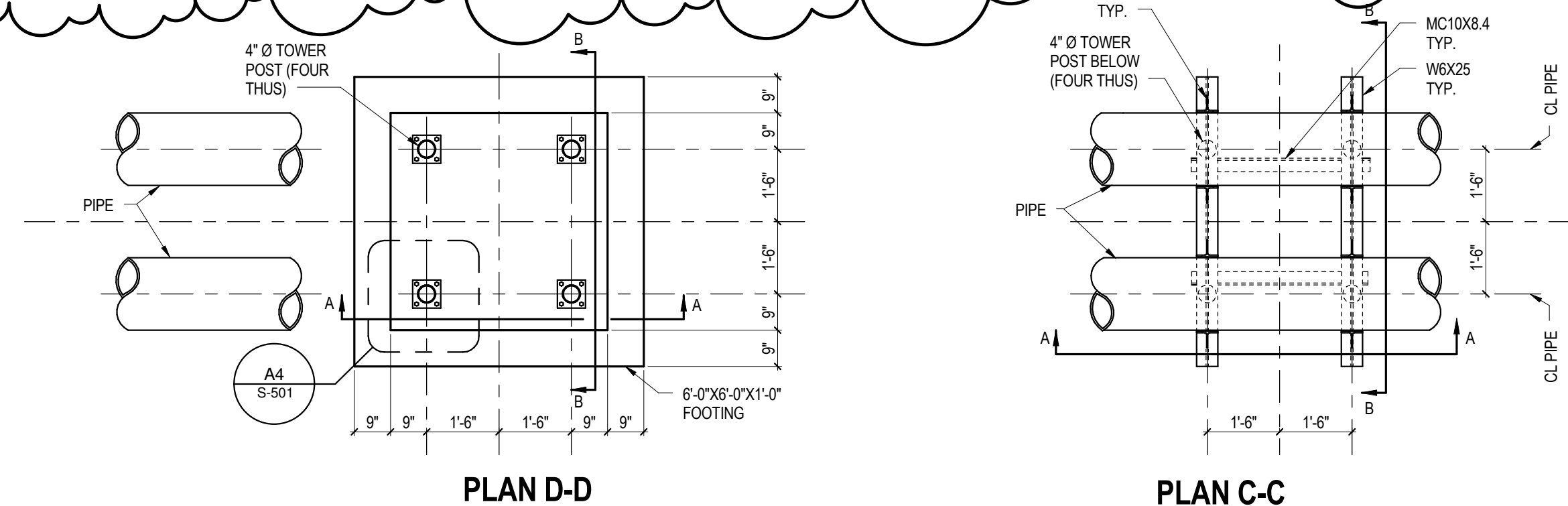

PLAN D-D

PLAN C-C

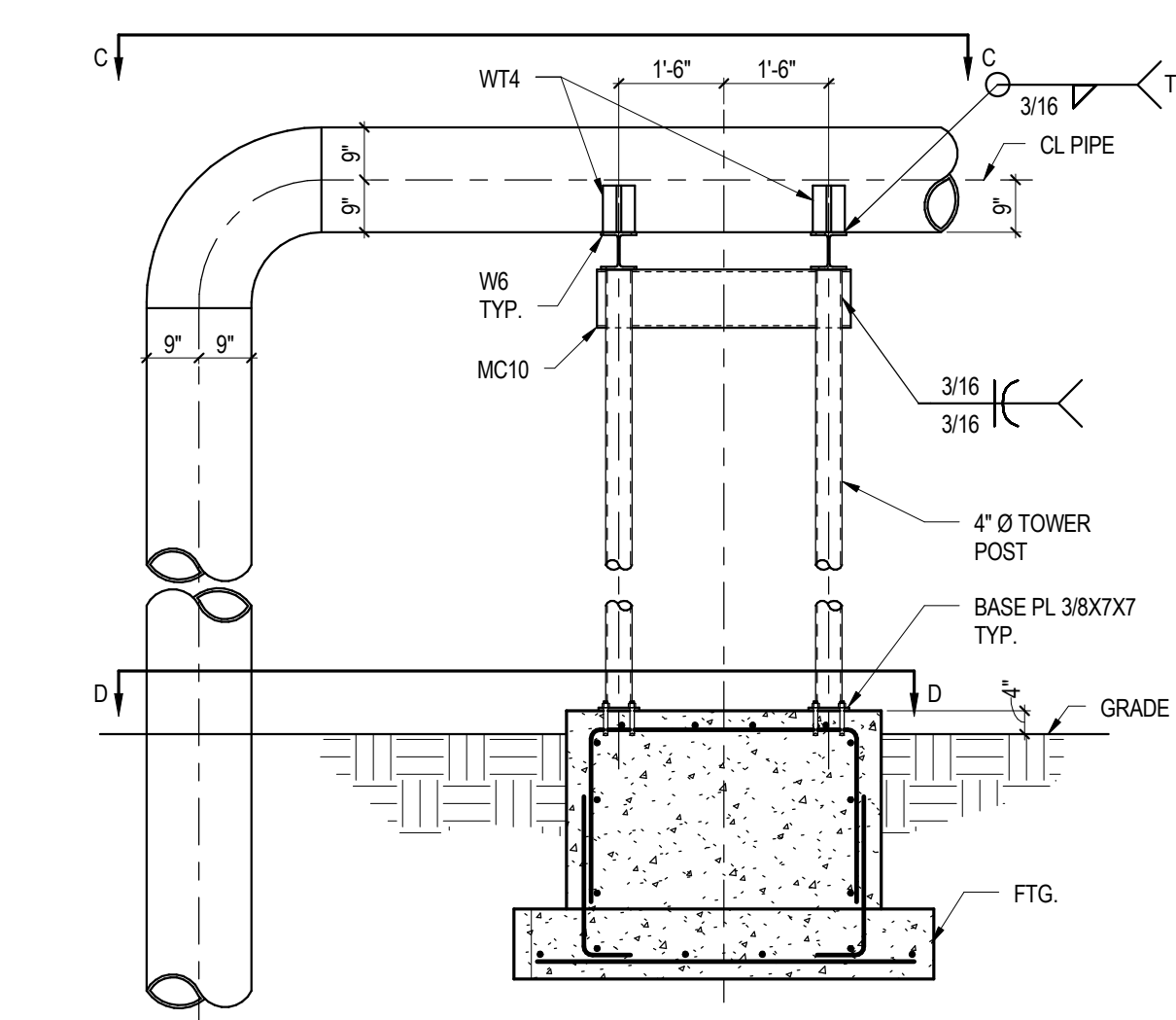

SECTION A-A

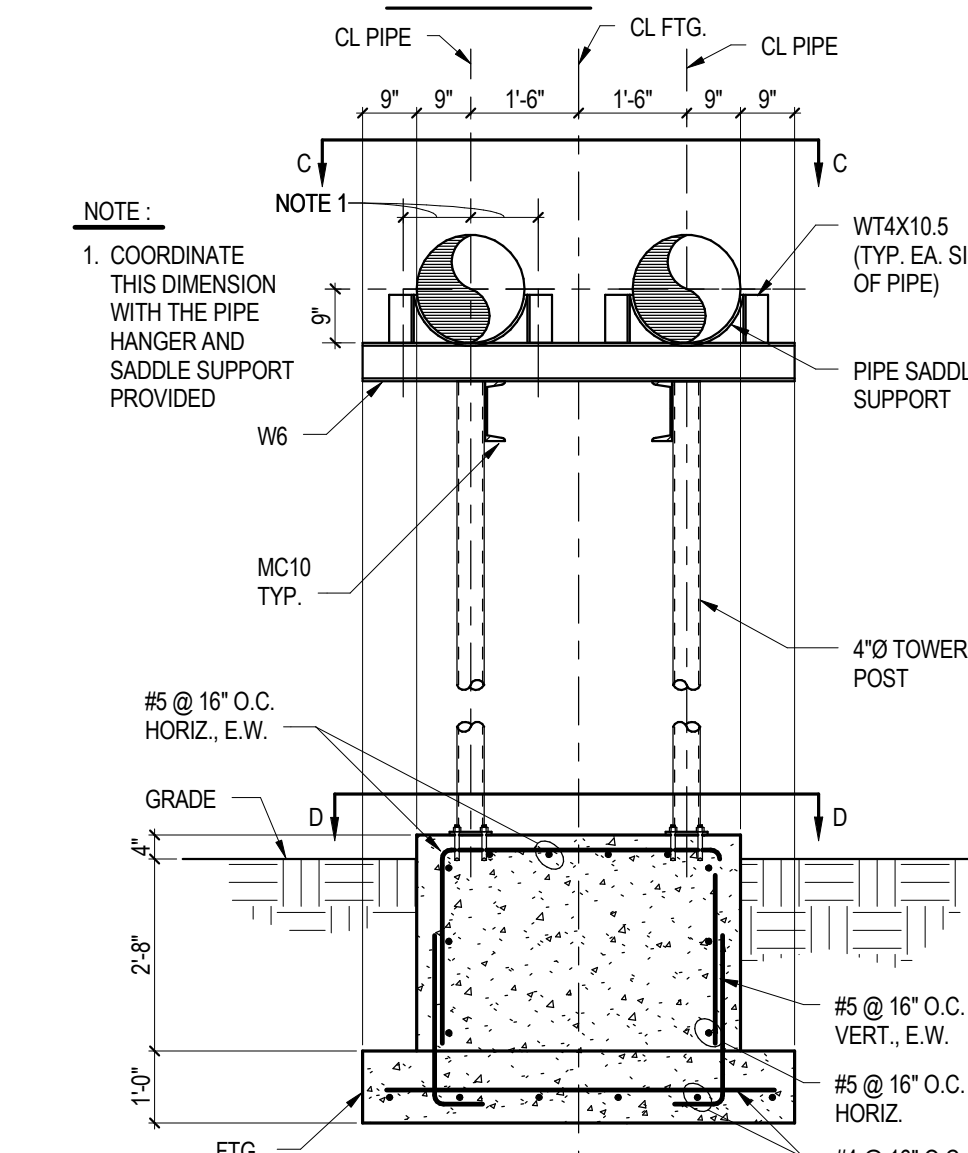

SECTION B-B

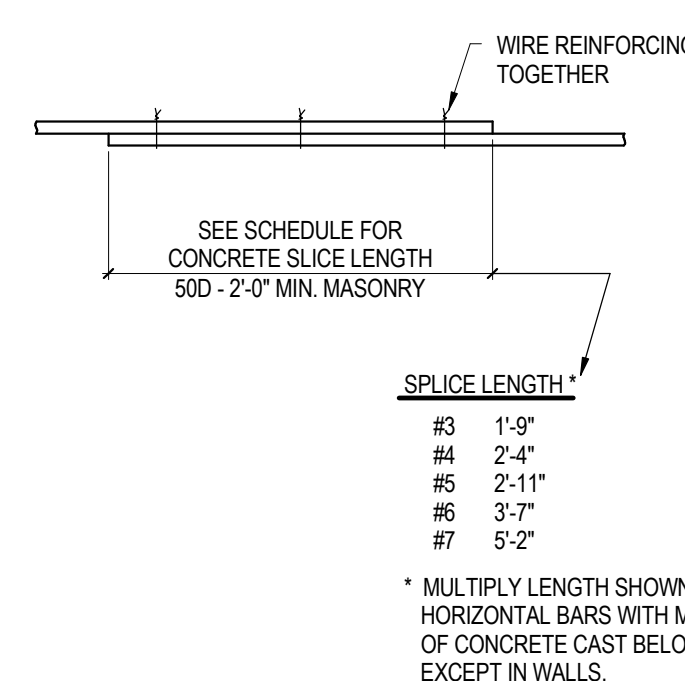

**A3** REINFORCING BAR SPLICE DETAIL  
3/4" = 1'-0"

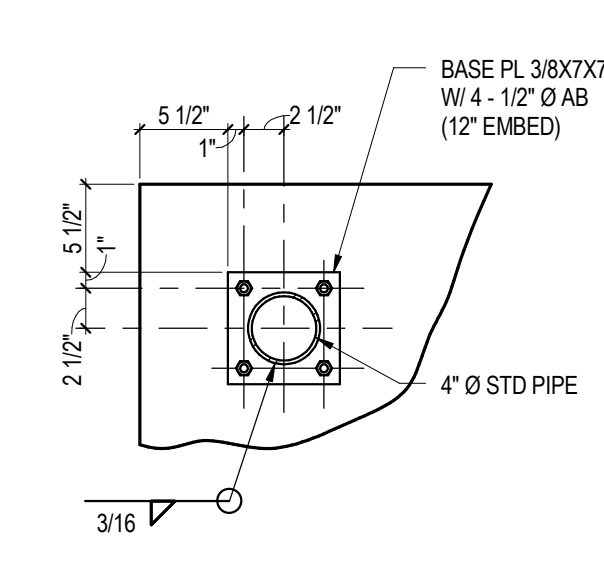

**A4** PIPE TOWER BASE PLATE  
1" = 1'-0"

**A5** PIPE SUPPORT FOOTING  
3/8" = 1'-0"

PROJECT FOR  
**UNIVERSITY  
 NEBRASKA  
 MEDICAL CENTER**  
 CAMPUS SITE  
 UTILITY  
 IMPROVEMENTS

UNMC PROJECT:  
 P-14037



MARK	DATE	DESCRIPTION
▲	05/19/2014	ADDENDUM NO. 1
	05/02/2014	CONSTRUCTION DOCUMENTS

PROJECT NUMBER	009567 / 21753
ORIGINAL ISSUE	05/02/2014
PROJECT MANAGER	ANDREW YOSTEN
PROJECT DESIGNER	LARRY LOFTUS
PROJECT ARCHITECT	LARRY LOFTUS
LANDSCAPE ARCHITECT	BRAD SWERCZEK
CIVIL ENGINEER	-
STRUCTURAL ENGINEER	MIKE KUHSE
MECHANICAL ENGINEER	ANDREW YOSTEN
ELECTRICAL ENGINEER	TIM KOCH
INTERIOR DESIGNER	-
EQUIPMENT PLANNER	-
DRAWN BY	JAMES NOWAK



5/2/14

**PARTIAL  
 MECHANICAL  
 SITE PLAN**

SCALE 1" = 20'-0"

**M-101**

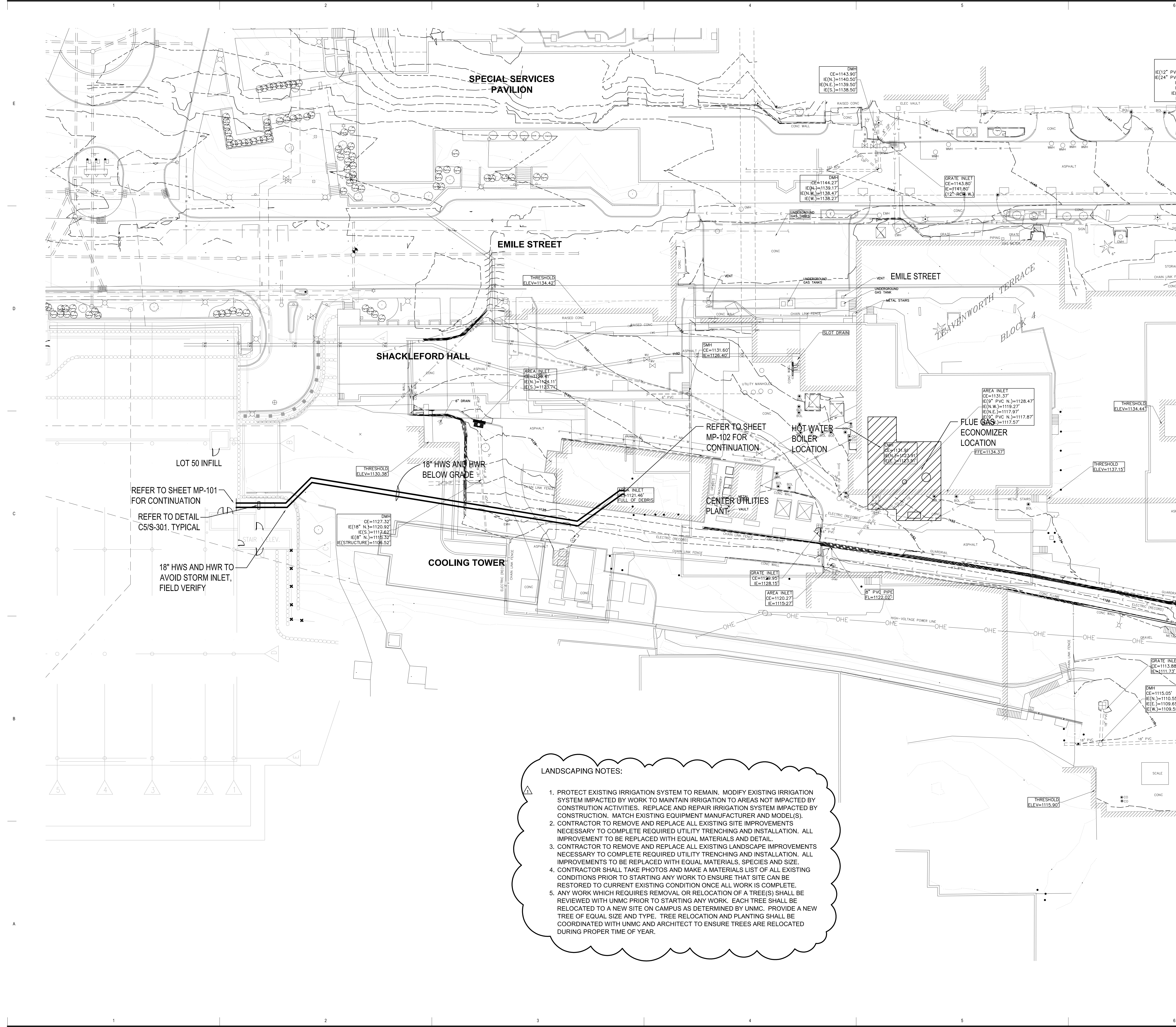

**LANDSCAPING NOTES:**

1. PROTECT EXISTING IRRIGATION SYSTEM TO REMAIN. MODIFY EXISTING IRRIGATION SYSTEM IMPACTED BY WORK TO MAINTAIN IRRIGATION TO AREAS NOT IMPACTED BY CONSTRUCTION ACTIVITIES. REPLACE AND REPAIR IRRIGATION SYSTEM IMPACTED BY CONSTRUCTION. MATCH EXISTING EQUIPMENT MANUFACTURER AND MODEL(S).
2. CONTRACTOR TO REMOVE AND REPLACE ALL EXISTING SITE IMPROVEMENTS NECESSARY TO COMPLETE REQUIRED UTILITY TRENCHING AND INSTALLATION. ALL IMPROVEMENT TO BE REPLACED WITH EQUAL MATERIALS AND DETAIL.
3. CONTRACTOR TO REMOVE AND REPLACE ALL EXISTING LANDSCAPE IMPROVEMENTS NECESSARY TO COMPLETE REQUIRED UTILITY TRENCHING AND INSTALLATION. ALL IMPROVEMENTS TO BE REPLACED WITH EQUAL MATERIALS, SPECIES AND SIZE.
4. CONTRACTOR SHALL TAKE PHOTOS AND MAKE A MATERIALS LIST OF ALL EXISTING CONDITIONS PRIOR TO STARTING ANY WORK TO ENSURE THAT SITE CAN BE RESTORED TO CURRENT EXISTING CONDITION ONCE ALL WORK IS COMPLETE.
5. ANY WORK WHICH REQUIRES REMOVAL OR RELOCATION OF A TREE(S) SHALL BE REVIEWED WITH UNMC PRIOR TO STARTING ANY WORK. EACH TREE SHALL BE RELOCATED TO A NEW SITE ON CAMPUS AS DETERMINED BY UNMC. PROVIDE A NEW TREE OF EQUAL SIZE AND TYPE. TREE RELOCATION AND PLANTING SHALL BE COORDINATED WITH UNMC AND ARCHITECT TO ENSURE TREES ARE RELOCATED DURING PROPER TIME OF YEAR.

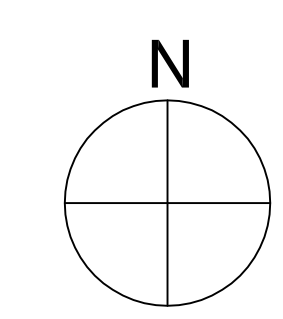













**GENERAL NOTES:**  
 A. EXISTING MECHANICAL WORK IS INDICATED BY BEING SHOWN LIGHT.  
 B. NEW MECHANICAL WORK IS INDICATED BY BEING SHOWN BOLD.  
 C. ALL WORK IN TUNNELS SHALL BE REVIEWED WITH OWNER PRIOR TO STARTING WORK TO ENSURE COORDINATION WITH OTHER CAMPUS PROJECTS.  
 D. CONTRACTOR SHALL COORDINATE PROTECTION OF AND COORDINATION WITH UNMC TELECOMM CABLES LOCATED IN TUNNELS. COORDINATE WITH TERRY O'CALLAGHAN (UNMC).

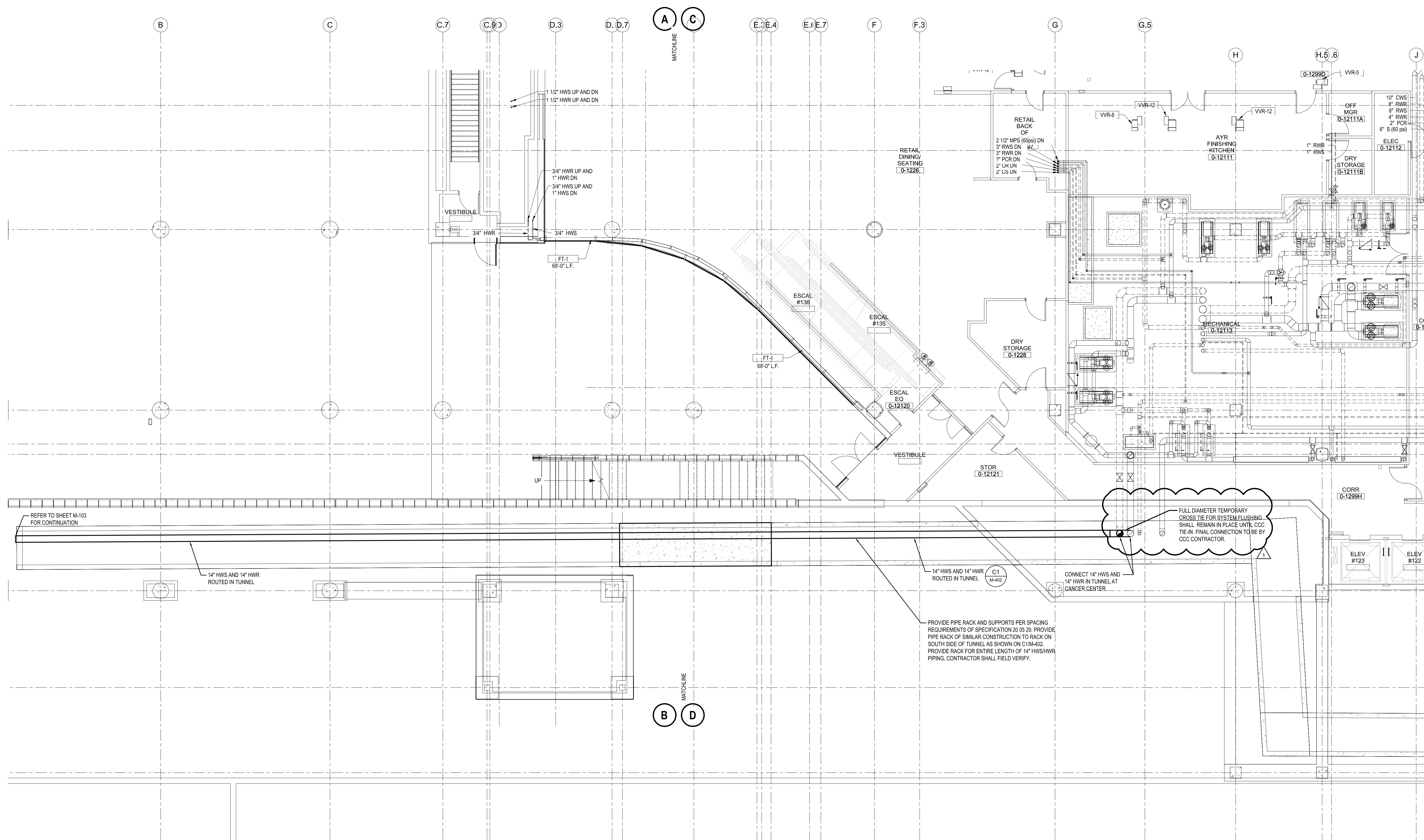

PROJECT FOR  
**UNIVERSITY NEBRASKA MEDICAL CENTER**  
 CAMPUS SITE UTILITY IMPROVEMENTS  
 UNMC PROJECT: P-14037



MARK	DATE	DESCRIPTION
△	05/19/2014	ADDENDUM NO. 1
	05/02/2014	CONSTRUCTION DOCUMENTS
<b>PROJECT NUMBER</b> 099967 / 217523		
<b>ORIGINAL ISSUE</b> 05/02/2014		
<b>PROJECT MANAGER</b> ANDREW YOSTEN		
<b>PROJECT DESIGNER</b> LARRY LOFTUS		
<b>PROJECT ARCHITECT</b> LARRY LOFTUS		
<b>LANDSCAPE ARCHITECT</b> BRAD SWERCZEK		
<b>CIVIL ENGINEER</b> -		
<b>STRUCTURAL ENGINEER</b> MIKE KUHSE		
<b>MECHANICAL ENGINEER</b> ANDREW YOSTEN		
<b>ELECTRICAL ENGINEER</b> TIM KOCH		
<b>INTERIOR DESIGNER</b> -		
<b>EQUIPMENT PLANNER</b> -		
<b>DRAWN BY</b> JAMES NOWAK		

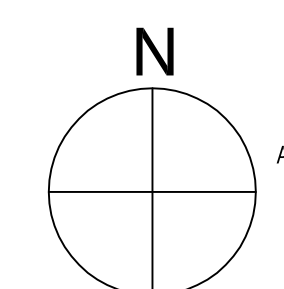
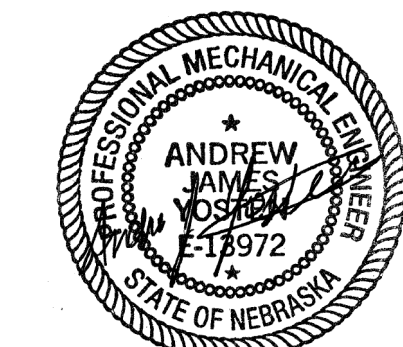

**PARTIAL GROUND LEVEL MECHANICAL PUMP ROOM PLAN (CANCER CENTER)**

SCALE 1/8" = 1'-0"

**MP-10G**

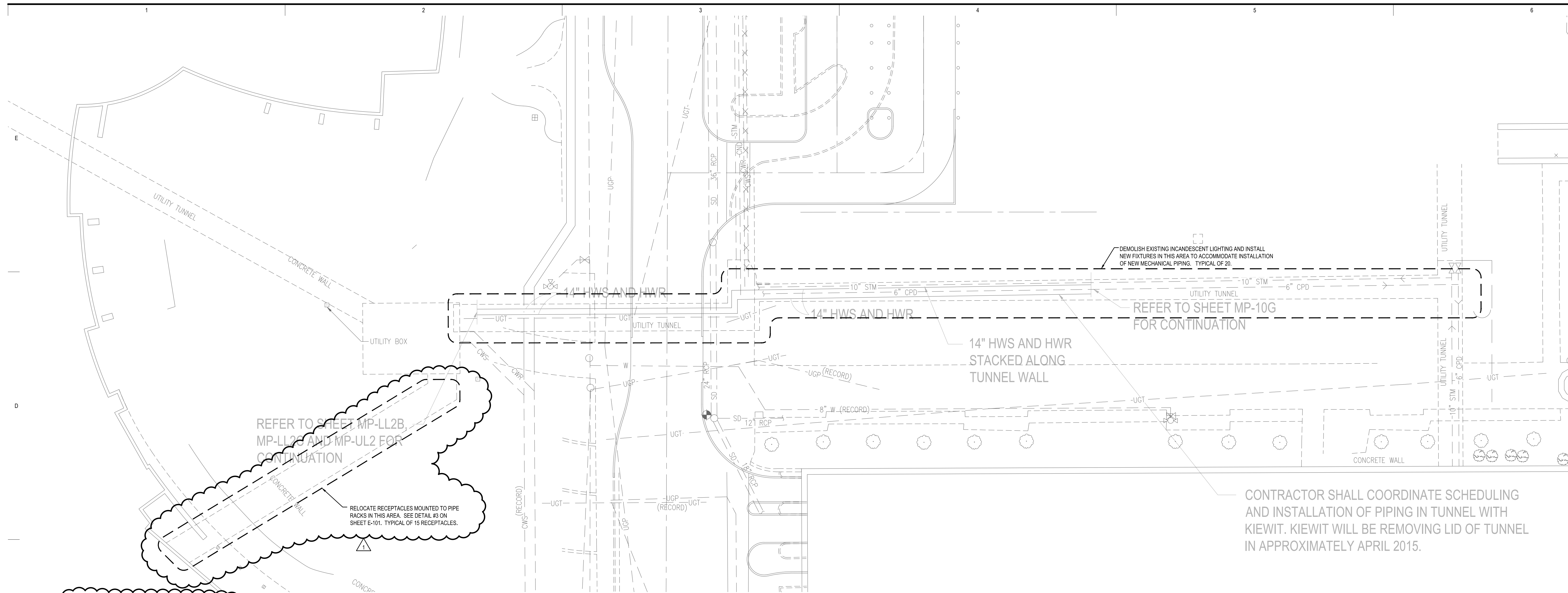

**1** UTILITY TUNNEL PLAN

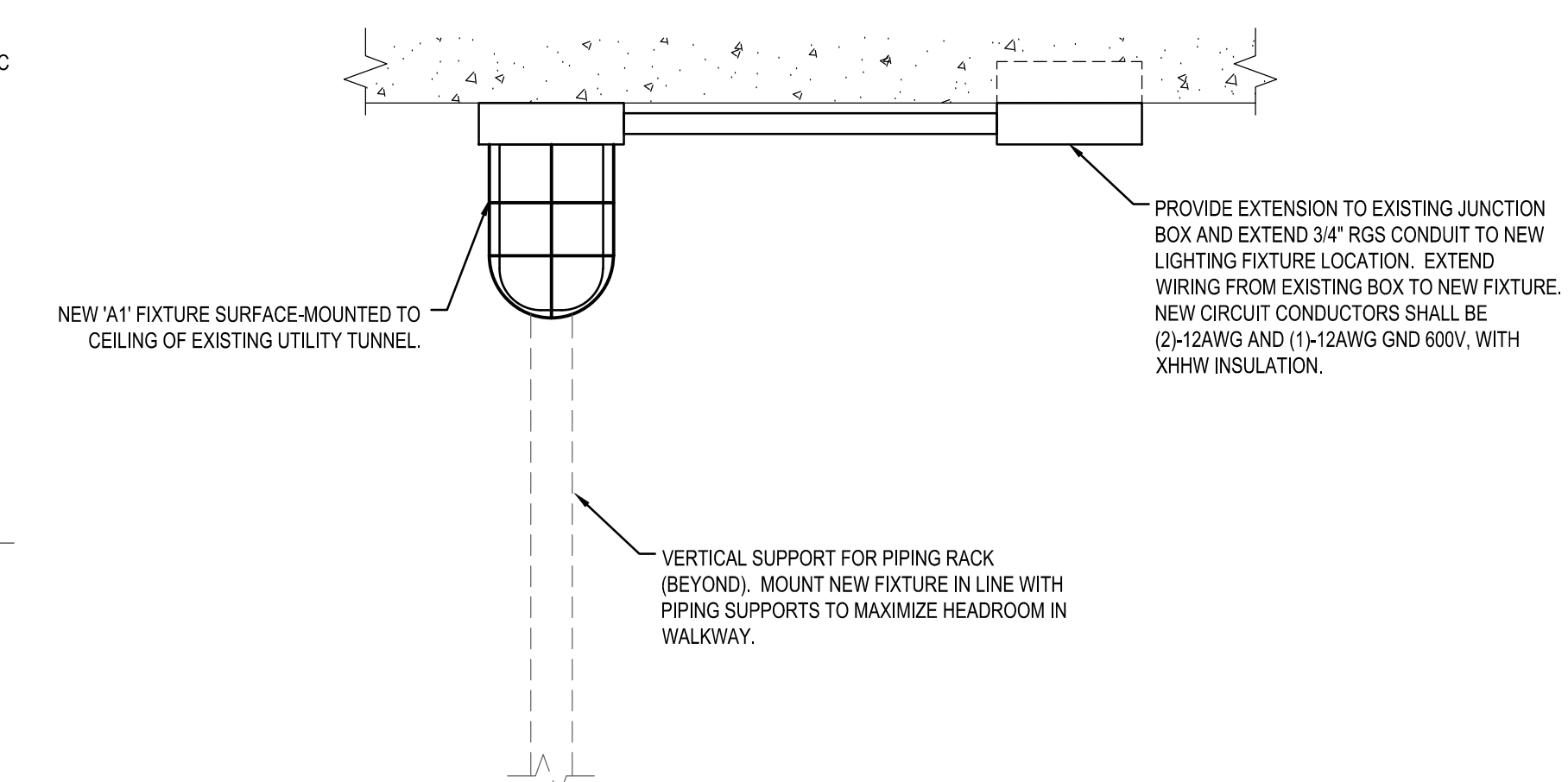

**2** LIGHTING INSTALLATION DETAIL

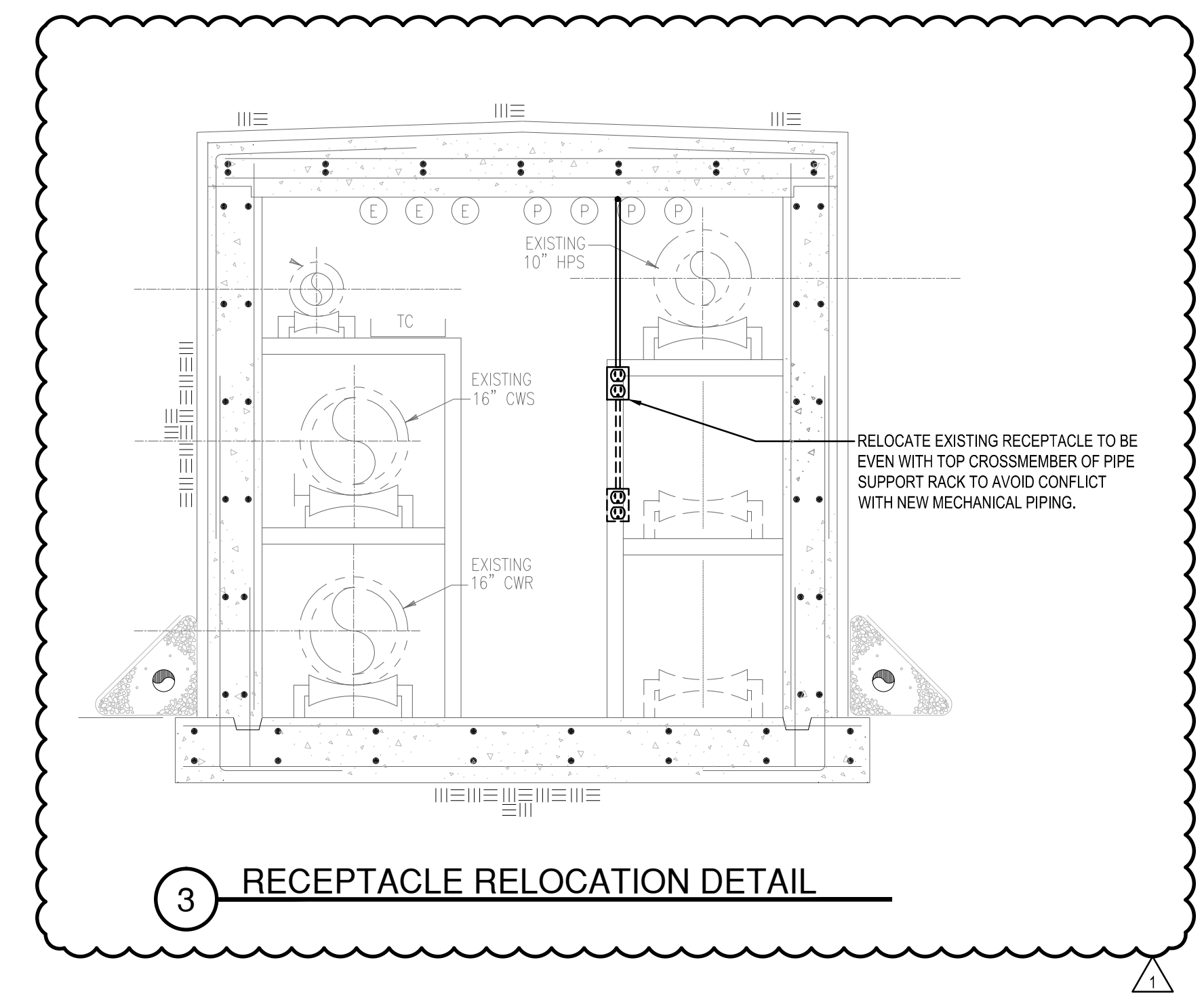

**3** RECEPTACLE RELOCATION DETAIL

CONTRACTOR SHALL COORDINATE SCHEDULING AND INSTALLATION OF PIPING IN TUNNEL WITH KIEWIT. KIEWIT WILL BE REMOVING LID OF TUNNEL IN APPROXIMATELY APRIL 2015.

PROJECT FOR  
**UNIVERSITY NEBRASKA MEDICAL CENTER**  
 CAMPUS SITE UTILITY IMPROVEMENTS

UNMC PROJECT:  
 P-14037



MARK	DATE	DESCRIPTION
1	05/19/2014	ADDENDUM NO. 1
	05/02/2014	CONSTRUCTION DOCUMENTS

PROJECT NUMBER	099987 / 217523
ORIGINAL ISSUE	05/02/2014
PROJECT MANAGER	ANDREW YOSTEN
PROJECT DESIGNER	LARRY LOFTUS
PROJECT ARCHITECT	LARRY LOFTUS
LANDSCAPE ARCHITECT	BRAD SWERCZEK
CIVIL ENGINEER	
STRUCTURAL ENGINEER	MIKE KUHSE
MECHANICAL ENGINEER	ANDREW YOSTEN
ELECTRICAL ENGINEER	TIM KOCH
INTERIOR DESIGNER	
EQUIPMENT PLANNER	
DRAWN BY	A. ROCHE

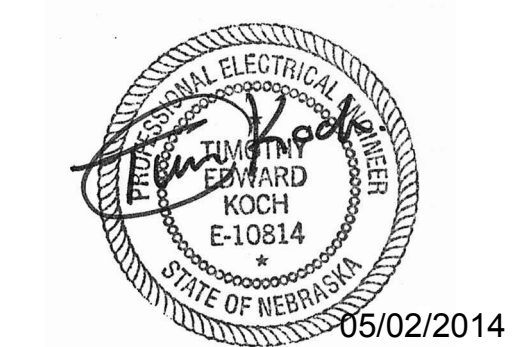

LIGHTING EQUIPMENT SCHEDULE									
TAG NO.	DESCRIPTION	MANUFACTURER & CATALOG NO.	LAMPS			ORDERING CODE	VOLTAGE	MOUNTING	NOTES
			QUANTITY	FLUOR	INCAN				
A1	4-1/2" X 10-5/8" Surface-mounted, Industrial Vapor-light LED fixture listed for wet locations. Fixture to have cast aluminum housing with protective cage and frosted glass diffuser. Nominal 6000 lumen output Consuming 15Watts.	Base: Liforix OLVTCM-4000-MVOLT  Optional Manufacturer(s): RAB Lighting, Cooper Lighting			15	Provided with Luminaire	120	Ceiling (Surface)	

**ELECTRICAL TUNNEL PLAN**

SCALE: AS NOTED