

833-001-13

ADDENDUM NO. 1

The Architect/ Engineer issues this addendum, applicable to the above named project, to all known Contractors before receipt of proposal.

This addendum includes Item Number 1-1 thru 1-20. This addendum item shall be fully incorporated into the Bidding/Contract Documents and have the same force and effect as though originally included.

The Bidder shall acknowledge receipt of this Addendum No. 1 on the Bid Proposal Form in the place provided.

GENERAL

Item 1-1: Advertisement for Bids

Change the bid date from November 20, 2013 to **November 27, 2013 at 2PM.**

ARCHITECTURAL

Specifications

Item 1-2: Section 08 11 13 – Hollow Metal Doors and Frames

- Refer to section 2.8 – Fabrication, door construction under section 2.8, B shall comply with the requirements of section 2.3 for core construction.
- Refer to section 2.8 – Fabrication, delete requirement for Terminated Stops, section 2.8, C, 7.

Item 1-3: Section 08 41 13 – Aluminum Entrances and Storefronts

Refer to section 2.5, A, entrance door construction shall be 1 ¾" standard storefront door not 2" to 2 ¼" thermally broken door

Item 1-4: Section 08 71 00 – Door Hardware

Refer to section 3.7, A, subject to compliance with the requirements of this section, add the following:

- Continuous Gear Hinges – add Stanley
- Hinges – add Stanley
- Locks – add Best Locks
- Exit Devices – add Precision
- Closers & Auto Operators – add Stanley

833-001-13

Item 1-5: Section 10 22 37 – Sound Control Operable Wall System

Refer to section 2.2, A, 1, subject to compliance with the requirements of this section, add the following manufacturers:

- Advanced Equipment
- Modernco Operable Panels
- Hufcor Inc.
- Modenfold Inc.
- Panelfold Inc.

Item 1-6: Section – GT-E Overhead Electric Cranes

Add this section in its entirety; this section replaces all previously issued specifications.

Drawings

Item 1-7: Sheet A1.11 – First Floor Reflected Ceiling Plan – Area A

Refer to General Reflected Ceiling Plan Notes #4. As a clarification, in Area A paint the exposed structure in the Canteen North (rooms 106, 107, 108, 109) and Canteen South (rooms 113, 114, 115, 116, 119) areas only, not the pre-engineered manufacturing areas.

Item 1-8: Sheet A1.12 – First Floor Reflected Ceiling Plan – Area B

Refer to General Reflected Ceiling Plan Notes #4. As a clarification, in Area B no exposed ceiling structure in Electrical / Server 145 and Custodial 154 is to be painted. Exposed perimeter steel columns are to be painted.

Item 1-9: Sheet A6.40 – Door Schedule, Door Types, Frame Types

Refer to Aluminum Frames Type ALF-101, modify the top member from 6" to 2" height. Modify the bottom sill member from 6" to 4 ½" (side light base)

Refer to Aluminum Frames Type ALF-102, modify the bottom sill member from 6" to 4 ½" (side light base)

Item 1-10: Sheet F1.01 – First Floor Finish Plan – Area A, Canteen N & S

Refer to Room Finish Schedule – Area A. As a clarification, in Area A paint the exposed structure in the Canteen North (rooms 106, 107, 108, 109) and Canteen South (rooms 113, 114, 115, 116, 119) areas only, not the pre-engineered manufacturing areas.

Item 1-11: Sheet F1.02 – First Floor Finish Plan – Area B

Refer to Room Finish Schedule – Area B. As a clarification, in Area B no exposed ceiling structure in Electrical / Server 145 and Custodial 154 is to be painted. Exposed perimeter steel columns are to be painted.

833-001-13

STRUCTURAL

Specifications

Item 1-12: Section 31 20 01 – Earth Moving – Building Only

Refer to paragraph 2.1.D, CHANGE text to read: Drainage Course (granular base): Clean, fine graded material with at least 10 to 30% of particles passing a No. 100 sieve but not contaminated with clay, silt, or organic material; ASTM D 448; unwashed Size No. 10. Material shall have a uniform distribution of particle sizes ranging from No. 4 to the No. 200 sieve. Refer to ASTM C 22, Table 1, for limitation of deleterious material finer than No. 200. **Crushed concrete may be used provided that it meets the following gradation requirements: 100% passing the 1 1/4 inch sieve, 95% ±5 passing the 1 inch sieve, 81% ±12 passing the 3/4 inch sieve, 38% ±12 passing the No. 4 sieve, 24% ±11 passing the No. 10 sieve, 9% ±5 passing the No. 40 sieve, 3% ±3 passing the No. 200 sieve.**

Refer to paragraph 2.1.D.1., CHANGE text to read: 4" below 8" slabs

Item 1-13: Sheet S1.01 – Footing and Foundation Plan

- Reference Structural Materials List, Concrete, Compressive Strength chart, Add the word "Piers" after Grade Beams.
- Reference slab note near grid intersection Q-10, revise granular base thickness from 6" to 4".

Item 1-14: Sheet S2.02 – Foundation Details

Add Detail 12 Makeup Air Unit Pad Detail, see attached Supplemental Drawing SDS-001.

MECHANICAL

Specifications

Item 1-15: Section 22 07 19 – Plumbing Piping Insulation

Refer to paragraph 3.4.A. Add under

PIPING SYSTEM:	PIPE SIZE,	THICKNESS
Domestic Cold Water Supply	6" & smaller	1"

Drawings

Item 1-16: Sheet M2.02 – Facility Piping Plan & Sheet M2.03 – Enlarged Piping Plans

Plumbing contractor is responsible for hanging water heaters via unistrut or angle iron above mop sinks. No drain pan is necessary under the water heaters.

833-001-13

ELECTRICAL

Specifications

Item 1-17: Specification 28 31 00 – Fire Alarm System

Revise 1.1.E-6 to state: Digital fire communicator (DACT)

Replace 2.1 (A)-7 to state the following:

- a. Digital fire communicators (DACTs) shall be a Silent Knight 5128 or 5129 and shall be installed in the fire control cabinet or mounted in a separate enclosure. Refer to the drawings for installation details. The slave communicator shall be powered by 24 VDC from a UL listed fire alarm control and shall report (4) conditions: alarm, trouble, supervisory alarm and water flow alarm. The unit shall have built in auxiliary relay output which is programmable for alarm or trouble conditions, and shall be capable of transmitting a distinctive AC power failure signal.
- b. The communicators shall have the following features: visual and audible trouble indications; supervised or unsupervised input channels, dual phone line interface with line seizure; local and remote programming and automatic 24-hour test.
- c. The communicators shall be UL 864 listed and meet the requirements of NFPA 72, chapter 4 for supervising station fire alarm systems.
- d. Provide all necessary power and signaling cabling between the fire alarm panel and DACT as necessary for the required signaling.

Remove section 2.3 and 2.3(A)

Item 1-18: Sheet E2.01 through E2.06 – Power and Auxiliary Systems Plan

Refer to Gantry Crane and Overhead Crane electrical connections. Electrical Contractor shall be responsible for installing all Duct-O-Bar runs and any all electrified components (quick disconnect(s), power feeds, etc.). The electrical contractor is responsible for all electrical connections and installations for/to cranes as per "Overhead Cranes Specification".

TELECOMMUNICATIONS

Drawings

Item 1-19: Sheet T0.01, T1.01, T1.02 – Telecommunications Plans & Specification 27 00 00

Note: All work shown on Telecommunications sheets (T0.01, T1.01 & T1.02) and all work associated with Specification 27 00 00 (Telecommunications Cable Plant), shall be bid as a separate line item.

833-001-13

Item 1-20: Sheet T2.01 – Telecommunications Riser & Details Plan

Refer to the Electrical/Server room 145 riser diagram.

Plan note number eight shall be changed to read the following: "SIX 48 PORT PATCH PANELS FOR TERMINATION OF ALL BLUE HORIZONTAL DATA CABLING. SEE THE SPECIFICATIONS FOR ADDITIONAL INFORMATION."

Plan note number ten shall be changed to read the following: "TWO 48 PORT PATCH PANELS FOR TERMINATION OF ALL WHITE HORIZONTAL VOICE CABLING. SEE THE SPECIFICATIONS FOR ADDITIONAL INFORMATION."

END OF ADDENDUM NO. 1

OVERHEAD ELECTRIC CRANES
ADDENDUM ONE 11-13-2013
Replaces all previously issued specifications

1. GENERAL

1.1 DRAWINGS ATTACHED TO THIS SET INCLUDING GENERAL AND SUPPLEMENTARY CONDITION.

A. References:

1. American Institute of Steel Construction
2. AISC 2005 2005 Steel Construction Manual 13th Edition
3. ASME B30.2 2003 Overhead and Gantry Crane (top running Bridge single or multiple girder.
4. ASME HST-4 1999 Overhead Electric Wire Rope Hoists
5. CRANE MANUFACTURERS ASSOCIATION OF AMERICA CMA
6. CMAA 70 2004 top running bridge
7. CMAA 74 2004 Top Running Girder Hoist

1.2 SUMMARY

A. Top running Single Girder Overhead Electric Cranes listed as follows:

1. [2] 10 ton top running Single girder Bay F-C
2. [1] 5 ton top running Single girder Bay K-F
3. [1] 5 ton top running Single girder Bay N-K
4. [1] 10 ton top running Single girder Bay R-N
5. [1] 5 ton top running Single girder Bay U-R
6. [1] 10 ton top running Single girder Bay X-U
7. This section consists of furnishing all labor, materials, tools and equipment necessary to supply and install complete functioning crane systems, traveling cranes, trolleys, rails, hoists and related equipment. Work shall be done in compliance with industry standards as a minimum. All work to be coordinated with all other related trades.

1.3 RELATED WORK

- A. Overhead crane supplier shall supply and install crane rails that are within tolerances per CMAA 70 prior to actual installation of the bridge cranes. Work shall be coordinated with the runway beam supplier/installer as required.
- B. An electrical quick disconnect (floor operated) will be provided for each crane by the Electrical Contractor. Coordinate location of disconnect with General Contractor.

1.4 PERFORMANCE REQUIREMENTS

- A. All cranes shall operate in the bays designated and shall match the runway dimensions stated on these drawings, with field verification. Hook coverage, vertical travel, clear hook height, lifting capacity shall be as specified. Load testing required for each installation.

- B. Classification: All cranes shown shall be classed "C" and designed and constructed to meet CMAA 70. Class "C" Moderate Service for indoor non-hazardous installations

1.5 SUBMITTALS

A. Product Data:

1. Submit with bid manufacturer's product information, specifications for hoists, trolley, cranes, pendants, duct-o-bar and all accessories.
2. Shop Drawings: Submit clearance drawings for all cranes and hoists and trolleys as well as cut sheets on all supplied equipment and devices included in the installation package.
3. Provide Crane Test Data, (Load Test) on load test forms for each crane suitable for the life of the crane.
4. Maintenance and operation manuals for each crane and all supplied equipment. Submit [3] copies of bound manuals for each crane and lifting device with operating and maintenance manuals and instructions, parts list, purchase source listing and wire rope and load hook test certificates.
5. Calculations:
 - a. Provide ASCE rail sizing and associated calculations
 - b. Provide all necessary Electrical Diagrams and schematics containing complete wiring and schematic diagrams between crane components
 - c. Provide Structural Calculations related to Bridge Components and bridge Girders.

1.6 DELIVERY STORAGE HANDLING

- A. Protect Bridge Crane during transit, delivery to jobsite and handling to prevent damage. Store with protection from weather, humidity and temperature variations and contaminants as required. Touch up any damaged areas.

1.7 PROJECT CONDITIONS

- A. Coordinate installation of crane with the General Contractor to ensure Site Conditions are conducive to setting the crane. Due to the span of the cranes the area below must be considered safe and clear of objects and personal.
- B. Field measurements: before performing any works and setting any dimensional data for fabrication verify either on-site or with steel manufacturer correct dimensions of crane centers, rail centers, voltages etc. Particularly the verification of the ASCE Rail installed per CMAA 70, the spans and all clearances required.

1.8 WARRANTY

- A. The crane manufacturer will provide an executed minimum of [2] TWO year Warranty against defective material workmanship and installation. Normal wear items such as brake linings, hoist ropes, fuse, radio control batteries are excluded from the warranty.
- B. Crane supplier will provide [1] one annual inspection as a part of the warranty at no additional cost to the Owner. This inspection will be comprehensive and shall meet OSHA standards for the crane and related lifting accessories included with the crane package. This inspection shall be conducted at the same time as the annual 4th and final quarterly service inspection.

- C. Warrantee period begins after cranes have been commissioned, {installed, inspected, and load tested}.

1.9 TRAINING

- A. After the crane has been commissioned and final acceptance, the crane supplier shall provide on-site training to the Owners designated operators in safe operation and maintenance of the crane and crane systems and equipment. Training shall be inclusive including basic rigging, use of spreader beams and fork lifting devices.
- B. Training will include a one day session up to 8 hour maximum in time and can be a combination of classroom and field training. Rigging shall comprise a day of training.

1.10 MAINTAINENCE SERVICES

- A. Crane supplier to supply the Owner with quarterly inspection services that cover equipment manufacturer's recommendations. The first four quarterly services shall begin three months from the load test commissioning and the last shall coincide with the scheduled yearly inspection. The Crane supplier is to work with the Owners Staff to train them on the proper procedures for quarterly maintenance service. Crane supplier is to provide their own man-lift and necessary equipment.

2. PRODUCTS

2.1 CRANES

- A. Cranes shall be: [3] Three Five Ton and [4] Four 10 Ton Cranes for a total of [7] Seven girder, top running, remote floor controlled, all electric traveling cranes and shall conform to the following requirements: Note: There shall be [2] of the 10 ton Cranes in one Bay-Bay "F"- "C"
 1. Bridge Capacity [3] @ 5 tons [4] @ 10 tons
 2. Bridge Spans: [6] @ 47'-7" – [1] @ 43'-11 ½"-see plans for locations
 3. Hook Height 24'-0"
 4. Hoist lift 24'
 5. Hoist Lifting Speed 15 FPM feet per minute
 6. Hoist Motor-variable speeds up to 15 FPM
 7. Hoist Suspension-Motor Driven Trolle
 8. Hoist Speed 65 FPM feet per minute +- 10%
 9. Hoist Trolley Motor Variable Speed up to 65 FPM
 10. End Trucks designed to operate on ASSCE 40# railing (supplied by Crane Installer) w/"J" Bolt Connections-{also installed and supplied by Crane Contractor}. Bridge Crane manufacturer is to confirm rail sizing via submittals. All Rails to be supplied with adjustable end Stops as required.
 11. Dual 10 Ton Cranes in Bay "F" – "C" to have controls which prevent run up. They are to be supplied with collision avoidance system controls to prevent crane to crane collision.
 12. Bridge Crane Speed: 100 FPM feet per minute
 13. Bridge Motor: [Dual End Drive] variable speed 100 FPM
 14. Clear Height to bottom of Bridge Beam as required to support 24' hook height and shall not be below 24' above finish floor.
 15. Overhead Clearance: minimum OSHA requirement

B. Electrical Requirements

1. Bridge Drive -2 @ ¾ hp min for 5 ton-2@ 1.5 hp min for 10 ton.
2. Hoist Trolley Drives-2 @ ¼ HP min for 5 ton-2 @ .65 min for 10 ton.
3. Hoist Drive minimum 10 HP Motors min for 10 ton, 7.5 hp min for 5 ton.
4. All Motors shall be 480V 3 Phase 60 HZ
5. All power conductors for ALL bridges shall be Duct-O-Bar or Conductix-Wampfler, safety enclosed Figure "A" type. Size the bar to safely carry the worst case electrical load to be seen with the supplied crane.
 - a. Crane supplier to supply a 4 conductor system
 - b. "L" Shape brackets for the conductor bar system shall be welded to the runway beams. Brackets to be supplied by the Crane Installer/Supplier, Bracket to be Welded to the Runway Beam by the Building Erectors Certified Welders to locations and spacing's supplied and verified by the Crane Supplier.
 - c. Installation of power supply and power feed to the runway conductor bar system shall be at the Center of the runways. Prior to ordering verify with the Electrician/Electrical Engineer as to the location of feeds.
 - d. Installation of the quick disconnect [operating floor], the power feeds, and the duct-o-bar system is by the **Electrical Contractor**. Coordinate with Crane Supplier.
 - e. Verify with Electrician/Electrical Engineer which side of cranes to be electrified.
 - f. All Wiring Connection to be Clearly Marked inside Electrical Enclosures and shall tie to and wiring schematics provided with the devices.
 - g. The Project **ELECTRITION shall be responsible for installing all Duct-O-Bar runs and any and all Electrified components. NO EXCEPTIONS.**

C. Additional Requirements

1. Crane to be shipped complete with hoist installed and fully wired and pre-tested in the factory. In not the components to be field installed and clearly marked to ensure square connections. Additional instructions/drawings to be provided for any field installation of the crane. Wiring shall be also be clearly marked for field installation if hoist is shipped loose with a provided wiring diagram.
2. End Trucks to be dual motor end drives with a drive and idler wheel for each truck. Trucks shall be tube or channel type with a wheel base of a minimum 1/8 off the crane span per CMAA. Trucks shall have bolted connections to the bridge beams. A rubber bumper shall be mounted to the end of each end truck of sufficient size for the application.
3. End truck wheels shall be double-flanged; flame hardened and shall have tapered or flat treads for self-alignment to prevent skewing or excessive flange wear.
4. End truck drives shall be supplied with spring loaded AC Disc Brakes. Brakes shall have a torque rating of at least 50% of the bridge drive motor rated torque. Drives shall be A-4 drive arrangement mechanically connected through gear reduction and drive shafts to the drive wheels.
5. Bridge Girders are NOT required to be welded box sections.
6. Hoist Trolley motors shall include spring loaded electric disc brakes. Brakes shall have a torque rating of at least 50% of the bridge drive motor rated torque.
7. Bridge and end trucks shall use the rotating axels style drives.
8. Bridge Cranes to utilize fully notched girder beams with bolted squaring plate connections.
9. Hoist to utilize an upper and lower geared limit switch for precision spotting. In addition, a weight operated upper reserve plugging limit switch is to be provided. Hoist to also utilize a capacity limiter for overload protection.

10. Hoist Rope shall be of proper design and construction for the crane being supplied. Hoisting ropes shall be rated capacity load plus the load block weight divided by the number of rope parts, and shall not exceed 20% of the published I certified breaking strength of the rope.
11. Bridge panels to include Allen Bradley manual disconnects (rod operated).
12. All enclosures to be a minimum of NEMA 12 rating.
13. Bridge Trolley, and hoist and hoist trolley to utilize either Magnetek G+ Mini or Hitachi AC adjustable frequency drives.
14. Primary control of bridge crane shall be via an independent eight button [8] push button station radio remote. Manufacturer I Model = Enrange Rex08. Provide [2] step controls for ALL motions. Radio shall be provided with a rechargeable battery w/ charging station supplied, 1 spare Transmitter, combo kit, pre-installed horn kit meeting industry db requirements, and a charger station. Mainline Emergency stop feature shall be provided with transmitters. Frequency of transmitters to be verified w/ Owners on-site equipment so as not to cause conflict with his equipment.
15. Bridge crane to be supplied with independent traveling festoon system as manufactured by Duct-O-Wire or Conductix-Wampfler, no exceptions. Selector Relay switch at control panel shall allow end user to switch back and forth between radio and pendant control. Pendant Control shall provide 2 step control of maintained on/off switch. Round Pendant cord shall have internal strain relief wires and shall be set at 3'-6" above operating or finish floor. Pendant shall be shipped securely bound and bubble wrapped for protection.
16. All Bridge Crane runs shall include welded end stops that match up to the hoist trolley on either end. They shall be placed to maximize hook coverage.
17. Bridge Crane shall be primed and painted safety yellow. Markings on either side of the crane shall clearly identify the crane capacity, visible from the operating floor, and serial number. Hoist units shall have their rated capacity marked on the bottom block and on the hoist body. Crane shall be shipped with an extra gallon of finish coat paint to touchup.
18. Bridge and end truck wheels shall be hardened to 325 Bn.
19. Hoist shall be double reeved for true vertical lift.

D. ACCEPTABLE HOIST MANUFACTURERS:

1. Subject to compliance to the specification herein:
 - a. Detroit Hoist
 - b. Coffing
 - c. Yale

3. EXECUTION

3.1 GENERAL

- A. The crane erection shall be performed in accordance with the manufacturer's recommendations. Crane supplier to supply factory authorized representatives for initial startup and commissioning. NO EXCEPTIONS.
- B. Cranes shall be set up and adjusted after installation to ensure all equipment is operating within the performance requirements set forth. This shall include but is not limited to setting of all limit switches on hoist, setting drive speeds, verifying wire rope correctly sets on drum grooves, testing all controls and control functions of pendant, all safety features, radio remotes and lubrication as necessary.

- C. Crane supplier to coordinate with Selected Electrical Contractor on Conductor Bar Fig 8 system provided by Crane Supplier but installed by Electrical Contractor. Electrical Contractor to supply and install mainline disconnect [floor operated] to conductor bar system at operating floor level and within clear visual sight of operators.
- D. Crane supplier to coordinate with the Metal building supplier on ASC# 40# RAIL provided by Crane Contractor but installed by Metal Building Supplier/Erector. Installation by "J" Bolts supplied by Crane Supplier. Rail to be straight and level-laser checked and verified by Crane Supplier.
- E. Crane supplier to coordinate with Metal building Supplier/Erector on Conductor Bar Brackets supplied by Crane Supplier but installed by Metal Building/Erector's personal approximately 60" cc down all runways. Connections to be welded by certified welders.
- F. Crane supplier to coordinate and provide load testing on all installations to 125% of rated capacity and post initial inspection and prior to final acceptance of Crane. Load testing of the below hook lifting devices shall be completed at the manufacturers facility at 125% rated capacity. Testing shall be performed in front of representatives of the General Contractor. Test weights to be certified weights used for testing cranes only. No water weights will be allowed.

3.2 PROJECT CLARIFICATION NOTES:

- A. **Project Electrician:** will be required to install ALL ELECTRICAL COMPONENTS, supplied by Crane Supplier requiring licensed Electrical worker installation, including but not limited to; Duct-O-Bar, Mainline Disconnects to Conductor Bar. Additional requirements see these specifications.
- B. **Metal Building Supplier/Erector:** will be required to install Crane Supplier supplied a Duct-O-Bar welded support brackets on all crane runs, estimated @ 60" cc.

END OF SECTION

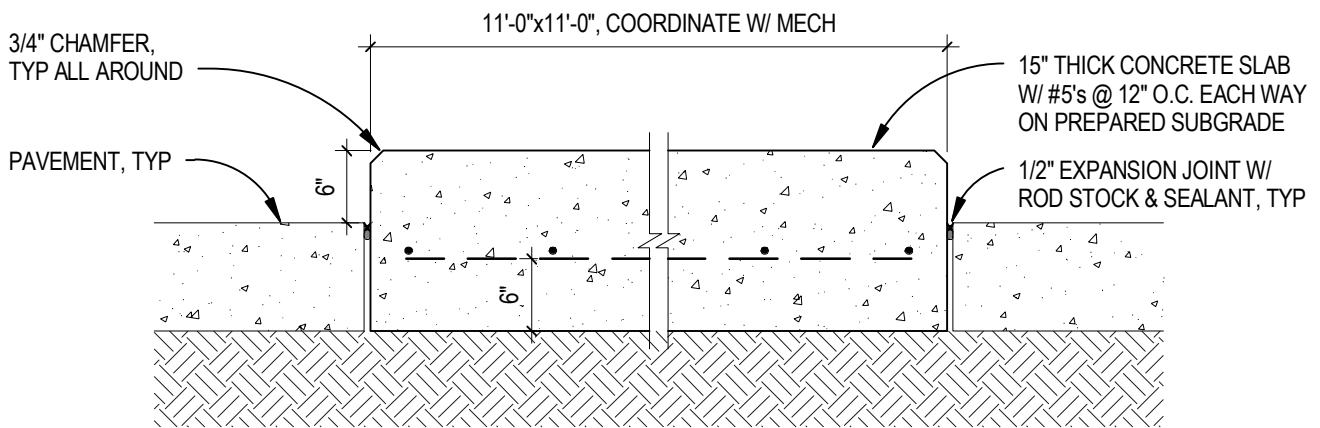
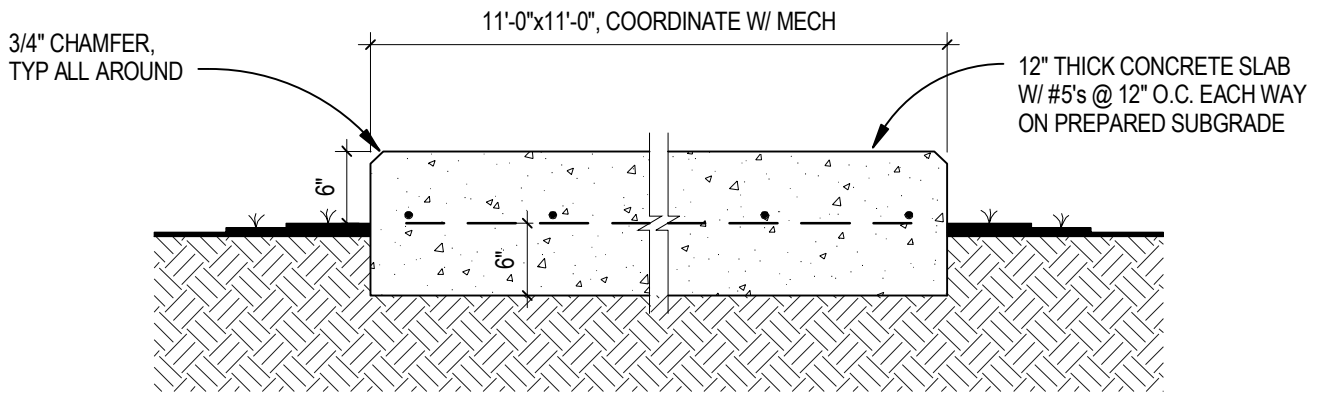

12 MAKEUP AIR UNIT PAD DETAIL

SCALE: 3/4" = 1'-0"

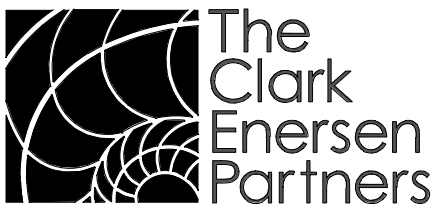

Architecture + Landscape Architecture + Engineering + Interiors
 1010 Lincoln Mall, Suite 200 Lincoln, NE 68508-2883
 402 477.9291 Fax 402 477.6542
 Kansas City, MO Fairway, KS www.clarkenersen.com

IAC / GT Exhaust
 Lincoln, Nebraska
 TCEP No.: 833-001-13

Addendum #01
 Supplemental Drawing: SDS-001
 Revision of Sheet: S2.02
 Date: 11/15/13