



**PROJECT:** UMO n HO n Nation Public School - Locker Room Addition – Final Package **DATE:** 23 August 2013

**PROJECT NO.** L13021

*This Addendum is issued by the Architect and Construction Manager to all bidders of record prior to receipt of proposals. Bidders shall acknowledge receipt of this addendum by so indicating on the Proposal Form. Failure to do so may subject Bidder to disqualification.*

*All information and instructions given herein shall become a part of the Contract Documents.*

**Project Manual:**

1. Section 002133–Instructions to Bidders: Replace Paragraph 2.03.A.3.a with new Paragraph as follows; "a. 3.2.2.1 In cases where discrepancies occur between the Drawings and Specifications, or separately in either the Drawings or Specifications, the Bidder is required to furnish the best quality of material and workmanship indicated or the higher cost detail or material, if Bidder has not requested clarification of such items by the Architect before submitting their proposal." Clarifications can only be addressed in the form of an Addendum."
2. Section 014000 Quality Requirements: Change Paragraph 1.07.A to read as follows; "A. Owner shall employ and pay for services of an independent testing / inspection agency to perform testing and inspection as indicated in individual specification sections. This does not include field inspection and testing as required by Mechanical and Electrical Divisions.
3. Section 015000 Temporary Facilities and Controls: At Paragraph 1.12 – Vehicular Access and Parking: Add Paragraph D as follows: "D. Coordinate use of existing on-site drives with Owners representative. Any existing paving or walks damaged by construction traffic or operations shall be removed and replaced at no cost to the Owner. Contractor shall document the condition of on-site drives and walks that may be subject to construction traffic or operations, via photography, prior to the beginning of construction, to establish a record of the existing paved conditions."
4. Section 033000 Cast In Place Concrete: Change the first sentence of the second Paragraph of 1.04.B.3 to read as follows; "The Contractor shall notify the Construction Manager at least 48 hours prior to requirement of the inspection."
5. Section 040511 Masonry Mortaring and Grouting: Delete Paragraph 2.06.
6. Section 042000 Unit Masonry: Delete Paragraph 3.17.B.
7. Section 051200 Structural Steel Framing: Change the first sentence of Paragraph 1.04.B.1 to read as follows; "1. The Contractor shall notify the Construction Manager at least 48 hours prior to requirement of the inspection."
8. Section 052100 Steel Joists: Change the first sentence of the second Paragraph of 1.06.B. to read as follows; "The Contractor shall notify the Construction Manager at least 48 hours prior to requirement of the inspection."



9. Section 053100 Steel Deck: Change the first sentence of Paragraph 1.04.B.1 to read as follows; "1. The Contractor shall notify the Construction Manager at least 48 hours prior to requirement of the inspection."
10. Section 072100 Thermal Insulation: Paragraph 2.01.A; Add ACH Foam Technologies, Foam Control Plus 250, 25 psi, R-10, Expanded Polystyrene (EPS), Masonry Cavity Wall Insulation as an approved product.
11. Section 072100 Thermal Insulation: Paragraph 2.01.B; Add ACH Foam Technologies, Foam Control Plus 250, 25 psi, R-10, Expanded Polystyrene (EPS), Foundation Perimeter Insulation as an approved product.
12. Section 096566 Resilient Athletic Flooring: Paragraph 2.01; Add Dynamic Sports Construction, Inc. – DynaFit 1" Interlocking Tiles, as an approved manufacturer / product.
13. Section 096566 Resilient Athletic Flooring: Delete Paragraph 3.01.C.
14. Section 096813 Carpet Tile: Delete Paragraph 1.04.G.
15. Section 096813 Carpet Tile: Replace Paragraph 3.01.C with new Paragraph as follows; "C. Owner shall employ and pay for services of an independent testing / inspection agency to perform testing of concrete sub-floor surfaces for moisture emission rate an alkalinity to ensure that they are dry enough and ready for flooring installation. If test results do not conform to manufactures recommendations, alternate installation methods and / or alternate adhesives are to be utilized. Construction Manager to coordinate."
16. Section 105100 Lockers: At Paragraph 2.01 Manufacturers; Add Olympus Heavy Duty Ventilated Lockers / HDV as an approved manufacturer for both Type 1 and Type 2 Lockers.
17. Section 312000 Earth Moving: Change the first sentence of Paragraph 1.04.A to read as follows; "A. Testing shall be contracted and paid for by the Owner."
18. Section 321000 Building Earthwork: Replace Paragraph 1.7.B with new paragraph as follows; "B. All earthwork shall be tested and inspected by a qualified geotechnical engineer registered in the State of Nebraska. In general, the services of the geotechnical engineer shall include whatever may be necessary to determine that all earthwork meets the recommendations of the geotechnical report and requirements of the contract documents. Following on-site inspections, a written report covering tests made, inspection work completed, and conclusions concerning the acceptability of the work shall be submitted to the Architect for review."
19. Section 321000 Earth Moving: Paragraph 1.7.D; Change reference of 'Soils Engineer' to 'Geotechnical Engineer'.
20. Section 321000 Earth Moving: Delete Paragraph 1.7.E.
21. Section 321313 Concrete Paving: Change Paragraph 1.04.A to read as follows; "A. The Owner will employ a testing laboratory to perform tests and to submit the test reports to the Engineer within 24



## **ADDENDUM #3**

PAGE 3 of 3

hours after tests. The Contractor shall notify the Construction Manager at least 48 hours prior to requirement of the inspection."

### **Drawings:**

21. Sheet A1.1 – Detail D1/A1.1: Replace Detail D1/A1.1 with revised Detail D1/A1.1 per attached Drawing ASD-01

### **Mechanical / Electrical:**

22. See attached Addendum 3 from Morrissey Engineering.

**END OF ADDENDUM**

### **Attachments:**

BVH ASD-01  
Morrissey Engineering Addendum 3

UMO n HO n NATION PUBLIC SCHOOL –  
 LOCKER ROOM / WEIGHTS ADDITION  
 FINAL PACKAGE - ADDENDUM 3

ASD-01



PROJECT: L13021  
 DATE: 8-23-2013

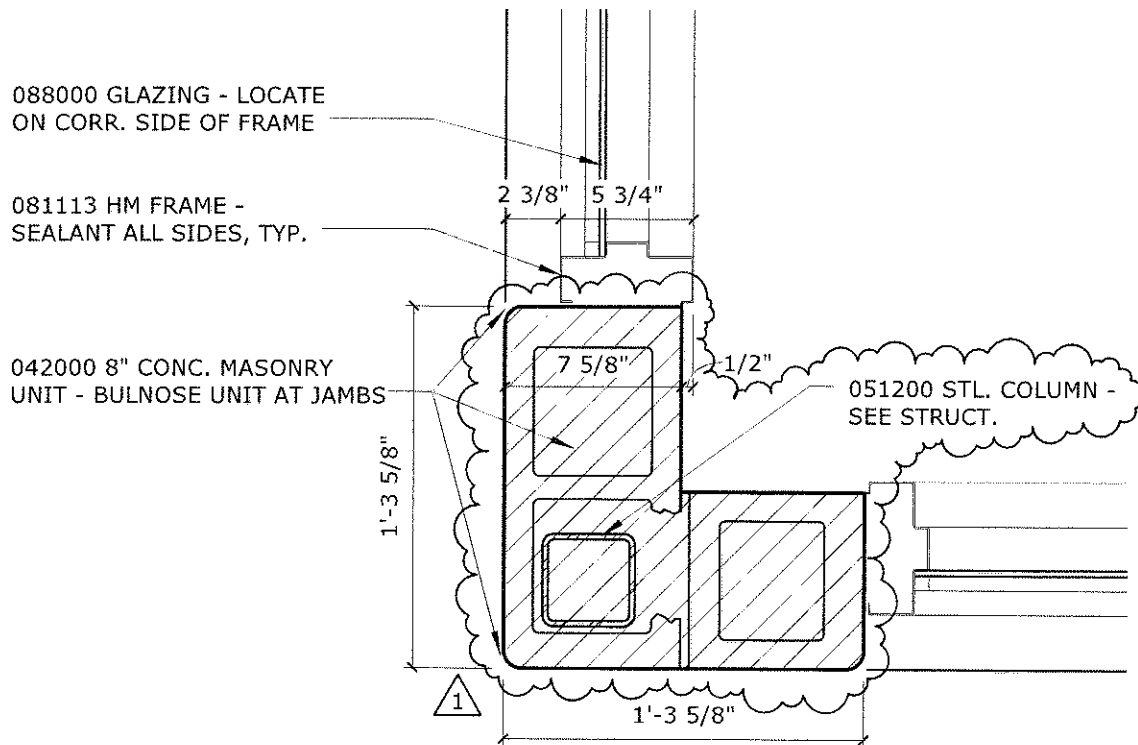

**D1** FRAME DETAIL

1 1/2" = 1'-0"

## addendum

---

**addendum no.** 03

**date:** August 22, 2013

**bid date:** August 29, 2013

**project name:** UNO n Ho n Nation Public School  
Locker Room / Weights Addition  
Final Package

**project no:** 13105

---

This addendum is hereby made a part of the contract documents to the same extent as if it were originally included therein. Contract documents shall be considered modified or revised as hereinafter described.

### ***mechanical items***

1. General – The following manufactures have been approved for the listed items. **All items shall meet the requirements of the construction documents, specifications and are subject for review during shop drawing submittal:**

	<b>Specification Section</b>	<b>Manufacturer</b>
a.	224000 Plumbing Fixtures	Zurn
b.	224000 Wash Fountains	Willoughby

### ***electrical items***

1. Lighting Fixture Schedule
  - a. Fixtures type 2 and 2E shall be considered equal as manufactured by Fail-Safe (Cooper).