

ADDENDUM NO. A

PROJECT NAME: Outdoor Adventure Center
UNL PROJECT NUMBER: C220P001
RFP# 909495-12
CONSULTANT: RDG Planning & Design
ADDRESS: 900 Farnam on the Mall, Suite 100, Omaha, NE 68102
DATE OF ISSUANCE: November 7, 2012
DATE OF BID OPENING: November 15, 2012

The bid documents dated October 8, 2012, for the above referenced project are amended by this addendum.

NOTICE: This Addendum is issued to all interested prospective bidders as an amendment to the project manual or other parts of the bidding (contract) documents for the above named project. Reference to this Addendum must be included in the Bid proposal. The information contained herein shall be fully incorporated into the contract documents as though originally included therein.

PRE-BID MEETING

The Pre-Bid Meeting was held on October 24, 2012, at 10:00 a.m. See attached list of attendees. The following questions were asked. Answers/clarifications are as follows:

APB-1 Section 00 45 13 – Request for Contractor Qualifications, Supplement to AIA Document A305: Is Bidder qualification required with our proposal on bid day or is this part of the post bid information?

Bidder qualifications are to be included as part of the bid package submitted on bid day.

APB-2 Section 01 10 00 – Summary of Work, Paragraph 1.5: Subparagraph D states all vehicles parked on University property will need parking permits. In Pre-Bid Meeting, it was stated that all vehicles in the construction staging area will not need parking permits. Please clarify.

All vehicles parked within the limits of construction do not need parking permits; any vehicles parked on University lots or streets on campus need permits.

ADDENDA TO THE PROJECT MANUAL

Procurement and Contracting Requirements (Owner-Provided)

APCR-1 Section 00 41 13 – Bid Proposal Form, Page 2 of 2: Add Alternate No. 9 (deduct) as follows:

***ALTERNATE NO. 9:** Delete the LED color-changing uplights, Fixture Types 11S and 11W, in the climbing center and the associated lighting controls, circuiting, and system programming.
DEDUCT the sum of _____ Dollars (\$_____).*

APCR-2 Section 01 23 00 – Alternates, Page 1 of 2, Paragraph 3.1: Add Alternate No. 9 (deduct) as follows:

***ALTERNATE NO. 9:** Delete the LED color-changing uplights, Fixture Types 11S and 11W, in the climbing center and the associated lighting controls, circuiting, and system programming.
DEDUCT the sum of _____ Dollars (\$_____).*

Civil Specification Items

ACS-1 Section 32 13 13 – Concrete Paving:

- A. Page 32 13 13-2:
 - 1. Paragraph 2.2: Remove Paragraph F (Color Pigment) in its entirety.
 - 2. Paragraph 2.3: Remove Paragraph 2.3 (Fiber Reinforcement) in its entirety.
- B. Page 32 13 13-3, Paragraph 2.5: Remove Paragraph B (Slip-Resistive Aggregate Finish) in its entirety.

ACS-2 Section 32 13 73 – Concrete Paving Joint Sealants, Page 32 13 73-2, Paragraph 2.2:

- A. Subparagraph C, Item 1: Add Sub-Item b:
 - b. Sikaflex 2c NS EZ-Mix by Sika Corp.*
- B. Subparagraph D, Item 1: Add Sub-Item b:
 - b. Sikaflex 1c SL by Sika Corp.*
- C. Subparagraph E, Item 1: Add Sub-Item b:
 - b. Sikaflex 2c SL by Sika Corp.*

Architectural Specification Items

AGS-1 Section 04 20 00 – Unit Masonry, Page 04 20 00-5, Paragraph 2.3, Subparagraph C, Items 6a and 6b: Revise to read:

- a. Size: Engineer 3-5/8 inches wide by 2-3/4 inches high by 7-5/8 inches long.*
- b. Color and Texture: **Yankee Hill Brick and Tile; G1, Antique finish.***

AGS-2 Section 04 72 00 – Cast Stone Masonry, Page 04 72 00-4, Paragraph 2.5: Add new Subparagraph B:

- B. Color: To match cast stone unit.*

AGS-3 Section 06 20 23 – Interior Finish Carpentry, Page 06 20 23-3, Paragraph 2.1, Subparagraph D: Add new Items 2, 3, and 4:

- 2. Joint Condition: Square edge open 1/8" butt joint"*
- 3. Install metal strapping at all vertical and horizontal joints to allow for proper anchor surface area. Fasten at 16-inches o.c. vertically along metal stud framing and 16-inches o.c. horizontally along the panel. Install fasteners minimum 1-inch from panel edge. Do not damage, mar, or cause the panel face to separate. Set fasteners flush with panel face; do not overdrive. Provide washer head screw fasteners.*
- 4.*

AGS-4 Section 07 19 00 – Water Repellents: Add new section. See attached Pages 07 19 00-1 through 07 19 00-4.

AGS-5 Section 07 41 13 – Metal Roof Panels, Page 07 41 13-3, Paragraph 2.1, Subparagraph B, Item 1: Add new Sub-Item b:

- b. Firestone Unaclad UC-6.*

AGS-6 Section 07 42 13.53 – Metal Soffit Panels, Page 07 42 13.53-3, Paragraph 2.2, Subparagraph B, Item 1: Add new Sub-Item d:

- d. Firestone Unaclad UC-750.*

AGS-7 Section 07 53 23 – Ethylene-Propylene-Diene-Monomer (EPDM) Roofing, Page 07 53 23-8: Modify roof warranty to be "15 years."

AGS-8 Section 07 92 00 – Joint Sealant, Page 07 92 00-6, Paragraph 3.7, Subparagraph A, Item 1: Add new Item c:

- c. Pecora 890 NST by Pecora Corp.*

AGS-9 Section 08 41 13 – Aluminum-Framed Entrances and Storefronts, Page 08 41 13-4, Paragraph 2.1, Subparagraph A: Add new Item 5:

- 5. Manko Series by Manko Windows Company.*

AGS-10 Section 08 44 13 – Glazed Aluminum Curtain Walls, Page 08 44 13-4, Part 2 – Products, Paragraph B: Add new Item 5:

5. ***Manko Series by Manko Windows Company.***

AGS-11 Section 08 71 00 – Door Hardware, Page 08 71 00-5, Paragraph 2.3, Subparagraph B, Item 2: Add Sub-Item b:

- b. ***Sargent 8200.***

AGS-12 Section 08 90 00 – Louvers and Vents, Page 08 90 00-3, Paragraph 2.3, Subparagraph A, Item 1: Add new Sub-Item k:

- k. ***United Enertech.***

AGS-13 Section 09 00 00 – Finish and Materials Legend:

A. Page 09 00 00-1:

1. Revise "ARPET TILE:" to read "CARPET TILE."
2. Ceramic Tile, CT-1: Add note in "Location" as follows:

(CT-1 to be used as floor tile in Alternate No. 2.)

B. Page 09 00 00-4: Add new section as follows:

FRP:

Location:

Walls adjacent to and extending one foot beyond the edge of service, floor and mop sinks to 4' AFF.

AGS-14 Section 09 21 46 – Fiber Cement Board, Page 09 21 46-3, Paragraph 3.3, Subparagraph A: Add new Items 3, 4, and 5:

3. ***Joint Condition: Square edge open 1/8" butt joint***
4. ***Install metal strapping at all vertical and horizontal joints to allow for proper anchor surface area. Fasten at 16-inches o.c. vertically along metal stud framing and 16-inches o.c. horizontally along the panel. Install fasteners minimum 1-inch from panel edge. Do not damage, mar, or cause the panel face to separate.***
5. ***Set fasteners flush with panel face; do not overdrive. Provide washer head screw fasteners.***

AGS-15 Section 09 77 00 – Fiberglass Reinforced Plastic Panels: Add new section. See attached Pages 09 77 00-1 through 09 77 00-4.

AGS-16 Section 09 91 00 – Paints and Coatings, Page 09 91 00-8, Paragraph 3.8, Subparagraph L, Item 3: Revise Sub-Item a to read:

a. **Products:**

- 1) ***IdeaPaint; Pro.***
- 2) ***Rust-Oleum Industrial Coatings – Rust-Oleum Dry Erase.***

AGS-17 Section 10 21 13.21 – Solid Composite Toilet Compartments: Section has been revised. See attached Pages 10 21 13.21-1 through 10 21 13.21-4.

AGS-18 Section 12 24 13 – Roller Shades: Remove section in its entirety.

Structural Specification Items

No items this addendum.

Mechanical Specification Items

AMS-1 Section 22 30 00 – Plumbing Equipment, Page 22 30 00-3, Paragraph 2.02: Add new Subparagraph C:

- C. ***PVI.***

AMS-2 Section 22 33 00 – Electric Domestic Water Heaters, Page 22 33 00-2, Paragraph 2.01, Subparagraph A, Item 1: Add new Sub-Item c:

- c. ***PVI.***

AMS-3 Section 22 40 00 – Plumbing Fixtures, Page 22 40 00-3, Paragraph 2.01:

A. Subparagraph C: Add new Item 4:

4. Moen.

B. Subparagraph D: Add new Item 3:

3. Moen.

AMS-4 Section 23 21 14 – Hydronic Specialties, Page 23 21 14-3, Paragraph 2.03, Subparagraph A, Item 1: Add new Sub-Item c:

c. Armstrong.

AMS-5 Section 23 22 14 – Steam and Condensate Heating Specialties, Page 23 22 14-4, Paragraph 2.03, Subparagraph A: Add new Item 11:

11. Sterling.

AMS-6 Section 23 31 00 – HVAC Ducts and Casings, Page 23 31 00-7, Paragraph 2.06, Subparagraph A, Item 4: Add new Sub-Items g and h:

g. Ducts on Demand.

h. Eastern Sheet Metal.

AMS-7 Section 23 33 00 – Air Duct Accessories:

A. Page 23 33 00-3, Paragraph 2.03, Subparagraph A: Add new Items 14 and 15:

14. NCA Manufacturing, Inc.

15. United Enertech.

B. Page 23 33 00-5, Paragraph 2.06, Subparagraph A: Add new Items 14 and 15:

14. NCA Manufacturing, Inc.

15. United Enertech.

C. Page 23 33 00-6, Paragraph 2.08, Subparagraph A: Add new Items 12 and 13:

12. NCA Manufacturing, Inc.

13. United Enertech.

AMS-8 Section 23 37 00 – Air Outlets and Inlets, Page 23 37 00-4, Paragraph 2.06, Subparagraph B: Add new Items 12 and 13:

12. NCA Manufacturing, Inc.

13. United Enertech.

AMS-9 Section 23 73 13 – Modular Central Station Air-Handling Units, Page 23 73 13-3, Paragraph 2.02: Add Subparagraph H:

H. Seasons 4.

AMS-10 Section 23 82 16 – Air Coils:

A. Page 23 82 16-2, Paragraph 2.01: Add Subparagraph L:

L. Seasons 4.

B. Page 23 82 16-2, Paragraph 2.02, Subparagraph A: Add Item 12:

12. Seasons 4.

C. Page 23 82 16-3, Paragraph 2.03, Subparagraph A: Add Item 12:

12. Seasons 4.

D. Page 23 82 16-4, Paragraph 2.04, Subparagraph A: add Item 12:

12. Seasons 4.

Electrical Specification Items

No items this addendum.

ADDENDA TO THE DRAWINGS

Civil Drawing Items

ACD-1 Sheet C0.2: Revise Second Demo Legend Key Note "T" to "V".

ACD-2 Sheet C1.1:

- A. Delete electric car/charging stations reference. Remove signs associated with these parking stalls.
- B. Delete three posts identified east of the bike lockers in the sidewalk. These were previously identifying posts for an overhang.
- C. Pea gravel is to be 12"-16" deep. Refer to Sheet C3.3 for detail to slope the subgrade towards the drain tile.
- D. Delete Note 11.1.
- E. Delete border and bollards around transformer. Coordinate with Electrical Site Plan for pad size and specifications. Refer to attached Supplemental Drawing SDC 001.
- F. Delete Brick Plaza Layout Plan.
- G. Revise limits of pea gravel to be located only within the area of the fall zone CIP wall (reference Detail 15/S7.02 for wall specifications). Top of wall to match architectural finish floor elevation at 100'-0". The radius of the CIP wall is 17'-8" measured at the centerline of the wall.

ACD-3 Sheet C3.3: Remove 32 linear feet of 4" drain tile and aggregate around drain tile from plan. Install 8" ADS inline drain-with 8" standard grate (or approved equal) within the area of the fall zone CIP wall (reference Detail 15/S7.02 for wall specifications). Install additional 17 linear feet of 4" storm sewer to connect to inline drain. Install 1-1/2" stone or cleaned recycled concrete (3" thick) on top of 8" drain and 3" around the perimeter of the drain. Top of pea gravel = 1153.00; top of 1=1/2" stone = 1151.65; grate rim elevation = 1151.40; flowline = 1148.75.

ACD-4 Sheet C4.1:

- A. Delete Note "R."
- B. Delete Note "H."
- C. Refer to attached Supplemental Drawing SDC 002 for pea gravel location (Note "N").
- D. Revise Key Note "N" to read:

12"-16" OF PEA GRAVEL, FOR PROTECTION ZONE. REFER TO SHEET C3.3 FOR DETAIL TO SLOPE THE SUBGRADE TOWARDS THE DRAIN TILE.'

- E. Add Detail '10' SIDEWALK EXPANSION – ALTERNATE 3': Refer to attached Supplemental Drawing SDC 003 for detail to be added.
- F. Revise Welded Wire Mesh Note in Sidewalk Detail to read:

WELDED WIRE MESH (6/6-10/10). REFER TO ASTM A185.
- G. Revise limits of pea gravel to be located only within the area of the fall zone CIP wall (reference Detail 15/S7.02 for wall specifications). Top of wall to match architectural finish floor elevation at 100'-0". The radius of the CIP wall is 17'-8" measured at the centerline of the wall.

Landscape Drawing Items

No items this addendum.

Architectural Drawing Items

AGD-1 Sheet A1.01: Elevation call out 1 and 7 on A10.1 should be revised to be 1 and 7 on "***A/13.01.***"

AGD-2 Sheet A2.01:

- A. Elevations 2, 14: Add Note "***ALTERNATE 2***" at Notes CT-4 and CT-5.
- B. Elevation 16: Delete Notes CT-4 and CT-5.
- C. Detail 17: Add note "***FRP AT MOP SINK AS SPECIFIED.***"

AGD-3 Sheet A2.02:

- A. Elevation 1: Delete note "PLAM CASEWORK – ALTERNATE" and replace with "***PLAM CASEWORK.***"
- B. Detail 5: Add note "***FRP AT MOP SINK AS SPECIFIED.***"

AGD-4 Sheet A2.03, Detail 7: Add note "***FIRE CABINET – AS SPECIFIED.***"

AGD-5 Sheet A3.01, Ceiling Type Key:

- A. Note 3: Delete "ACOUSTICAL TILE SYSTEM" and replace with "***ACOUSTICAL PANEL CEILING.***"
- B. Note 4: Delete "ACOUSTICAL TILE SYSTEM" and replace with "***ACOUSTICAL PANEL CEILING.***"
- C. Delete Note 5 in its entirety.

AGD-6 Sheet A4.01, General Roofing Notes, Note 5: Delete "1/2" THICK MECHANICALLY FASTENED WOOD FIBER INSULATION COVER BOARD" and replace with "***1/4" GLASS MAT GYPSUM COVER BOARD.***"

AGD-7 Sheet A7.01:

- A. Detail 13, Wall Section: Delete note "3/4" MEDIUM DENSITY FIBERBOARD" and replace with "***5/8"GYPSUM BOARD.***"
- B. Detail 14, Wall Section: Delete note "1/2" FIBER CEMENT BOARD" and replace with "***5/8"GYPSUM BOARD.***"

AGD-8 Sheet A10.01: Replace Door Schedule with attached Supplemental Drawing SDA-001.

AGD-9 Sheet A10.03:

- A. Delete "TYPE S-1" and replace with "***TYPE 14.***"
- B. Delete "TYPE S-2" and replace with "***TYPE 15.***"

AGD-10 Sheet A12.01:

- A. Detail 15: Delete 3-inch recess dimension; add note ***"INSTALL PER MFG RECOMMENDATIONS."***
- B. Detail 27: In room Climbing Center 104, revise note to read:
SLAB DEPRESSED 4 INCHES SOUTH OF THIS LINE FOR RUBBER FLOOR TILE, RUBBER FLOOR TILE N.I.C.
- C. Room Finish Schedule:
 - 1. Delete Area (SQFT) column.
 - 2. Room 103D: Delete FCB in all instances and replace with ***"GYF,"*** Finish ***"PT1."***
 - 3. Room 100B: Delete MDF at north, south, and east walls; replace with ***"GYF,"*** Finish ***"PT4."***

AGD-11 Sheet A13.01, Detail 10: Add ***"GRAPHICS BY OWNER"*** to Note "PT, SEE SCHEDULE GRAPHICS."

AGD-12 Sheet A14.01, Detail 26: Delete "CONCRETE TOPPING."

AGD-13 Sheet A14.02, Detail 23: Delete title and replace with ***"COMMERCIAL WASHER SECTION DETAIL."***

Structural Drawing Items

ASD-1 Sheet S1.01: Add note at footing occurring on Grid Line 6.1 from exterior to Grid Line A:

2'-6" WIDE X 3'-2" DEEP FOOTING W/ 3- #6 T AND B.

ASD-2 Sheet S1.03: Add operable wall beam per attached Supplemental Drawing SDS-001.

ASD-3 Sheet S7.01: Add Sections 9 and 10 per attached Supplemental Drawing SDS-002.

Mechanical Drawing Items

AMD-1 Sheet M1.1: Modify Flag Note 2 and add it in the Climbing Center 104. See attached Supplemental Drawing SDM-001.

Electrical Drawing Items

AED-1 Sheet E0.1: Clarify alternate number for courtyard site lighting. See attached Supplemental Drawing SDE-001.

AED-2 Sheet E1.1: Add alternate for LED uplighting and associated controls in climbing center. See attached Supplemental Drawing SDE-002.

AED-3 Sheet E5.1: Add alternate lighting fixture manufacturers. See attached Supplemental Drawing SDE-003.

END OF ADDENDUM NO. A

NS/jm

Enclosure:

- Pre-Bid Meeting List of Attendees
- Specification Section 07 19 00 – Water Repellents
- Specification Section 09 77 00 – Fiberglass Reinforced Plastic Panels
- Specification Section 10 21 13.21 – Solid Composite Toilet Compartments
- Supplemental Drawings SDC 001, SDC 002, and SDC 003
- Supplemental Drawing SDA-001
- Supplemental Drawings SDS-001 and SDS-002
- Supplemental Drawing SDM-001

Purpose: Pre Bid Meeting

Project Name: UNL Outdoor Adventures Center Project No.: C220P001

Date: 10/24/12 Time: 10:00 AM Location: UNL FPC 1901 Y Street

Name	Organization	Phone	Fax	E-Mail
JUSTIN CRAWFORD	Dartland	402-827-8223	402-330-2749	j Crawford@dartland.com
Bill Pele	SOS CONST.	402-250-7776		bill.Pele@gmail.com
Nathaniel Stahlmann	Stylized Concrete	402-306-9644	866-782-2852	Nathaniel@stylizedconcrete.com
Don Lundvall	Stylized Concrete	402-660-1747	866-782-2852	Don@stylizedconcrete.com
JUSTIN HURTZER	CHEEVER CONST	402-477-6745	402-477-2063	jhurtzer@cheeverconst.com
Jim Meyer	Meco-Herne Const	402-339-8127	402-339-8147	mmanuel@meherne.com
Brian Grimes	Sampson	402-434-5419	402-434-5466	brian.grimes@sampson-construction.com
Brent Smith	K&K Masonry	402-895-7962	402-895-9699	brents@kondkmasonry.com
KEVIN HERR	DICKER BUSHAM	402-641-4880	402-421-6021	Kevin.herr.dbr@gmail.com
Steve Hiemer	Kingery Construction Co.	402-465-4400	402-465-4529	steveh@kero.builders.com
Jared Bemis	Hausmann Const.	438-3230	438-3235	mattm@hausmannconstruction.com
RODNEY BRIDGEMANT	ELKHORN WEST CONST	402-315-9557	402-315-9415	RODNEY@ELKHORNWEST.COM
DAVID DUTRY	MEININGER FIRE PROT.	402-260-2600	402-260-2617	DAVID@MFP.INC.COM
REGAN ZELER	Lund-Ross	402-342-2810	402-342-8775	reganz@lundross.com
Jon Dybdal	Erich Braer Const	402-438-2165	402-438-2587	eb90138@windstream.net
Mitch Rowski	MidWest Paving	402-510-6407	402-537-3080	mosquiski@midwest-c.com
MATT HOEKE	SIEMENS	402-658-2585	402-658-2585	matthew.hoeke@siemens.com

Purpose: Pre Bid Meeting

Project Name: UNL Outdoor Adventures Center Project No. C220P001

Date: 10/24/12 Time: 10:00 AM Location: UNL FPC 1901 Y Street

Name	Organization	Phone	Fax	E-Mail
Scotty Halb	UNL FPC	472.4957		
Phil Palder	H+S	421-1573	421-1574	ppalder@hsphc.com
TOM NOHAN	RONCO CONST.	402 397-9109	402 397-8799	tomn@roncoomaha.com
Paul Pleskac	P&P inc	402)480 1409	402)461 2014	pleskacandpleskac@gmail
DAVE HIRON	EW-WELLS GROUP	214-397-9208	402-682-7499	DAVE.HIRON@WELLSGROUP.US
DAVE CRIBER	Phoenix Construction Group	402-504-9316	855-297-4226	dac@phxcoi.com
JASON HOUDEK	FALCON/MECHANICAL WESTERN	(402)474-7761		jhoudek@falconhvac.com
Brad Kohn	Great Plains Tie	402 850 1331		brad@greatplainssteel.com
Gene Benes	Benes Hgt/AC	402-783-2046	783-3263	marybenes@beneshvac.com
JOHN EIRICH	KIDWELL	402-475-9151	402-475-9186	jeirich@kidwell.us.com
CHRIS FOGARD	Boyd Jones	402 261 5077	402 261 5802	cfogard@boydjones.biz
Eric Neff	Nrc Group Inc	402-261-5481	402-261-5446	eneff@nrcgroupinc.com
Jordan Messerer	UNL Campus Rec	23467		
Todd Grider	UNL Campus Rec	2-1853		

SECTION 07 19 00 – WATER REPELLENTS

PART 1 - GENERAL

1.1 RELATED DOCUMENTS

- A. Drawings and general provisions of the Contract, including General and Supplementary Conditions and Division 01 Specification Sections, apply to this Section.

1.2 SUMMARY:

- A. Section includes penetrating water-repellent treatments for the following vertical and horizontal surfaces:
 1. Cast-in-place concrete, including site walls and benches.
 2. Cast stone.
 3. Concrete unit masonry.
 4. Clay brick masonry.

1.3 ACTION SUBMITTALS:

- A. Product Data: For each type of product indicated.
- B. Samples: For each type of water repellent and substrate indicated.
- C. Sustainable Design Submittals:
 1. Regional materials.
 2. Low-emitting materials.

1.4 INFORMATIONAL SUBMITTALS:

- A. Product certificates.

1.5 QUALITY ASSURANCE:

- A. Preinstallation Conference: Conduct conference at Project site.
- B. Applicator Qualifications: Minimum two years experience in work of this Section.
- C. Mock-Up:
 1. Size: 10'-0" x 10'-0" for each surface.
 2. Determine coverage rate for application.
 3. After curing, water test to verify sufficient coverage to repel moisture from surface.
 4. Verify that application of coating to substrate will not produce surface stains or discoloration.
 5. Allow 48 hours or until test patches are thoroughly dry before evaluating appearance, rate of application, compatibility, and effectiveness.

1.6 PROJECT CONDITIONS:

- A. Do not apply coating if:
 1. Ambient or surface temperature is below freezing.
 2. Possibility of entrapped or frozen water exists.
 3. Rain is expected during next 72 hours.
- B. Do not apply during high winds.
- C. Prevent overspray onto adjacent materials.

1.7 SEQUENCING:

- A. Allow new concrete to cure minimum 28 days before applying coating.
- B. Allow joint sealants to cure minimum 48 hours before applying coating.
- C. Allow water repellent to cure minimum five days before applying joint sealers to coated surfaces.

1.8 WARRANTIES:

- A. Provide manufacturer's 30-year warranty that treated surfaces will retain water and salt repellent properties.

PART 2 - PRODUCTS

2.1 MANUFACTURERS:

- A. Contract Documents are based on products by Prosoco.
- B. Substitutions: Under provisions of Division 01.

2.2 MATERIALS:

- A. Water Repellent:
 - 1. Product: Prosoco Blok Guard & Graffiti Control II.
 - 2. Description: Water-based, silicone emulsion, self-reactive, vapor permeable non-soluble, low-VOC water repellent, graffiti repellent, salt barrier, and dust proofer.
 - 3. Characteristics:
 - a. 20 percent solution tested to NCHRP 244:
 - 1) Reduction in Water Absorption: One day at 75 percent, 5 days at 78 percent, 21 days at 85 percent, average at 79 percent.
 - 2) Reduction in Chloride Ion Content: One day at 70 percent, 5 days at 81 percent, 21 days at 89 percent, average 80 percent.
 - 3) Water Vapor Transmission: 100 percent.
 - 4) Accelerated Weathering Test:
 - a) Resistance to Ultraviolet Light: No discoloration.
 - b) Reduction in Soluble Chloride: 91 percent.
 - b. Water Penetration; Tested to ASTM E514:
 - 1) 10 Percent Solution: 90 percent reduction.
 - 2) 20 Percent Solution: 90 percent reduction.
 - c. Resistance to Chloride Ion Penetration: 75 percent reduction; 20 percent solution tested to AASHTO T-259 and T-260.
 - d. Wind-Driven Rain: 200 hours with no effect, tested to Fed Spec TT-C-555B.
 - e. Water Repellency; Tested to Fed Spec SS-W-110C:
 - 1) 12.5 Percent Solution: 0.2 percent.
 - 2) 15.0 Percent Solution: 0.2 percent.
 - 3) 20.0 Percent Solution: 0.3 percent.
 - f. Water Vapor Transmission; Tested to ASTM E96:
 - 1) 3.1 perms up.
 - 2) 2.5 perms down.
 - g. VOC Content: <100.0 g/L, tested to ASTM D3960.

2.3 MIXES:

- A. Mix water repellent in accordance with manufacturer's instructions with clean water to 20 percent solution.

PART 3 - EXECUTION

3.1 EXAMINATION:

- A. Examine substrates, areas, and conditions, with Applicator present, for compliance with requirements and conditions affecting performance of the Work.
 - 1. Verify that surfaces are clean and dry according to water-repellent manufacturer's requirements. Check moisture content in representative locations by method recommended by manufacturer.
 - 2. Inspect for previously applied treatments that may inhibit penetration or performance of water repellents.
 - 3. Verify that there is no efflorescence or other removable residues that would be trapped beneath the application of water repellent.
 - 4. Verify that required repairs are complete, cured, and dry before applying water repellent.
- B. Test pH level according to water-repellent manufacturer's written instructions to ensure chemical bond to silica-containing or siliceous minerals.

3.2 PREPARATION:

- A. Cleaning: Before application of water repellent, clean substrate of substances that could impair penetration or performance of product according to water-repellent manufacturer's written instructions.
- B. Coordination with Mortar Joints: Do not apply water repellent until pointing mortar for joints adjacent to surfaces receiving water-repellent treatment has been installed and cured.
- C. Coordination with Sealant Joints: Do not apply water repellent until sealants for joints adjacent to surfaces receiving water-repellent treatment have been installed and cured.
 - 1. Water-repellent work may precede sealant application only if sealant adhesion and compatibility have been tested and verified using substrate, water repellent, and sealant materials identical to those required.

3.3 APPLICATION:

- A. Apply in accordance with manufacturer's instructions.
- B. Apply at rate recommended by manufacturer unless otherwise determined by testing of mock-up.
- C. Vertical Surfaces:
 - 1. Apply using low-pressure spray at 10 to 15 PSI with fan-shaped nozzle.
 - 2. Begin application at bottom of wall and work up.
 - 3. Flood surface until solution runs down 6 to 8 inches below spray pattern or sponge surfaces.

3.4 FIELD QUALITY CONTROL:

- A. Inspection: Inspect treated surfaces jointly with Architect; compare with characteristics of approved mock-up.
- B. Determine whether surfaces are adequately protected by water repellents.
- C. After coating has dried, test surfaces with water spray and material absorption tube test; reapply treatment to areas showing water absorption.

3.5 CLEANING:

- A. Immediately clean water repellent from adjoining surfaces and surfaces soiled or damaged by water-repellent application as work progresses. Correct damage to work of other trades caused by water-repellent application.
- B. Comply with manufacturer's written cleaning instructions.

END OF SECTION 07 19 00

SECTION 09 77 00 – FIBERGLASS REINFORCED PLASTIC PANELS

PART 1 - GENERAL

1.1 RELATED DOCUMENTS

- A. Drawings and general provisions of the Contract, including General and Supplementary Conditions and Division 01 Specification Sections, apply to this Section.

1.2 SUMMARY:

- A. Section includes special wall surfaces, including fiberglass reinforced plastic panels.
- B. Related Sections: Divisions 01 through 33 Sections for LEED requirements specific to the work of each of these Sections. Requirements may or may not include reference to LEED.

1.3 REFERENCES:

- A. General: Standards listed by reference, including revisions by issuing authority, form a part of this specification section to extent indicated. Standards listed are identified by issuing authority, authority abbreviation, designation number, title or other designation established by issuing authority. Standards subsequently referenced herein are referred to by issuing authority abbreviation and standard designation.
- B. American Society for Testing and Materials (ASTM):
 1. ASTM D2583 Standard Test Method for Indentation Hardness of Rigid Plastics by Means of a Barcol Impressor.
 2. ASTM D5420 Standard Test Method for Impact Resistance of Flat, Rigid Plastic Specimen by Means of a Striker Impacted by a Falling Weight (Gardner Impact).
 3. ASTM E84 Standard Test Method for Surface Burning Characteristics of Building Materials.

1.4 SYSTEM DESCRIPTION - PERFORMANCE REQUIREMENTS:

- A. Provide fiberglass reinforced plastic (FRP) panels which have been manufactured and installed to maintain performance criteria stated by manufacturer without defects, damage or failure.

1.5 SUBMITTALS:

- A. General: Submit listed submittals in accordance with Conditions of the Contract and Division 01 section "Submittal Procedures."
- B. Product Data: Submit product data, including manufacturer's SPEC-DATA⁹ product sheet, for specified products.
- C. Samples: Submit selection and verification samples for finishes, colors and textures. Submit 2 samples of each type of panel, trim and fastener.
- D. Closeout Submittals: Submit the following:
 1. Operation and Maintenance Data: Operation and maintenance data for installed products in accordance with Division 01 sections "Operation and Maintenance Data" and "Closeout Submittals." Include methods for maintaining installed products and precautions against cleaning materials and methods detrimental to finishes and performance.
 2. Warranty: Warranty documents specified herein.

1.6 QUALITY ASSURANCE - INSTALLER QUALIFICATIONS:

- A. Installer should be experienced in performing work of this section and should have specialized in installation of work similar to that required for this project.

1.7 DELIVERY, STORAGE, AND HANDLING:

- A. General: Comply with Division 01 section "Product Requirements."
- B. Ordering: Comply with manufacturer's ordering instructions and lead time requirements to avoid construction delays.
- C. Delivery: Deliver materials in manufacturer's original, unopened, undamaged containers with identification labels intact. Package sheets on skids or pallets for shipment to project site.
- D. Storage and Protection: Store materials protected from exposure to harmful weather conditions and at temperature and humidity conditions recommended by manufacturer. Store panels indoors in a dry place at the project site.
- E. Handling: Remove foreign matter from face of panel by using a soft bristle brush, avoiding abrasive action.

1.8 PROJECT CONDITIONS:

- A. Environmental Requirements:
 - 1. Installation shall not begin until building is enclosed, permanent heating and cooling equipment is in operation, and residual moisture from plaster, concrete or terrazzo work has dissipated.
 - 2. During installation, and for not less than 48 hours before, maintain an ambient temperature and relative humidity within limits required by type of adhesive used and recommendation of adhesive manufacturer.
 - 3. Provide ventilation to disperse fumes during application of adhesive as recommended by adhesive manufacturer.
- B. Field Measurements: Verify actual measurements/openings by field measurements before fabrication; show recorded measurements on shop drawings. Coordinate field measurements and fabrication schedule with construction progress to avoid construction delays.

1.9 WARRANTY:

- A. Project Warranty: Refer to Conditions of the Contract for project warranty provisions.
- B. Manufacturer's Warranty: Submit, for Owner's acceptance, manufacturer's standard warranty document executed by authorized company official. Manufacturer's warranty is in addition to, and not a limitation of, other rights Owner may have under Contract Documents.

PART 2 - PRODUCTS:

2.1 FIBERGLASS REINFORCED PLASTIC (FRP) PANELS:

- A. Manufacturer: Kemlite Company, Inc. or equal.
 - 1. Contact: PO Box 2429, Joilet, IL 60434; Telephone: (800) 435-0080, (815) 467-8600; Fax: (815) 467-8666; E-mail: kemlitesales@kemlite.com; Web site: www.glasbord.com.
- B. Proprietary Product(s)/System(s): Kemlite Fiberglass Reinforced Plastic (FRP) Panels or equal.
 - 1. Glasbord Panels:
 - a. Fire-X.
 - b. Color: As selected by Architect from manufacturer's standard colors.
 - c. Moldings: Provide harmonizing PVC (polyvinyl chloride) moldings.

2.2 MANUFACTURED UNITS - KEMLITE FIRE-X GLASBORD FIBERGLASS PANELS WITH SURFASEAL SURFACE PROTECTION:

- A. Rating: Fire-X Glasbord Underwriters Laboratories, Inc. (UL) classified, Class I (A) Interior Finish Material.
- B. Wall Panels: Finish, thickness and color shall be Embossed 0.09" (2.3 mm) Fire-X Glasbord with Surfaseal.
- C. Performance Properties: Provide products with the following properties:
 - 1. Underwriters Laboratories, Inc. (UL), Classified - Embossed standard Fire-X Glasbord 0.09" (2.3 mm) only.
 - 2. Class A flamespread of less than 25, smoke developed less than 450 per ASTM E84 latest version.
 - 3. Barcol Hardness (scratch resistance) of 55 as per ASTM D2583.
 - 4. Panels will exhibit no more than a 0.038% weight loss after a 25 cycle Taber Abrasion Test using CS-17 abrasive wheels with 1000 g weight.
 - 5. Gardner Impact Strength of 40 in-lb (4.5 J) showing no visible damage on front side per ASTM D5420.
 - 6. FMRC (Factory Mutual Research Corporation) approved Fire-X Glasbord FM.
 - 7. Meets USDA/FSIS requirements.
 - 8. Complies with ICBO Report Number 4583.
 - 9. A means of front side identification and confirmation of meeting Class I (A) interior finish requirements after installation and while in service (without labels), embossed FXI only.

2.3 ACCESSORIES - ADHESIVE:

- A. Provide panel adhesive as recommended by panel manufacturer.

2.4 SOURCE QUALITY:

- A. Obtain fiberglass reinforced plastic (FRP) panels from a single manufacturer. Provide panels and molding only from manufacturer specified to ensure warranty and color harmonization of accessories.

PART 3 - EXECUTION

3.1 MANUFACTURER'S INSTRUCTIONS - COMPLIANCE:

- A. Comply with manufacturer's product data, including product technical bulletins, product catalog installation instructions and product carton instructions for installation.

3.2 EXAMINATION - SITE VERIFICATION OF CONDITIONS:

- A. Verify that substrate conditions, which have been previously installed under other sections, are acceptable for product installation in accordance with manufacturer's instructions.
 - 1. Examine backup surfaces to determine that corners are plumb and straight, surfaces are smooth, uniform, clean and free from foreign matter, nails are countersunk and joints and cracks are filled flush and smooth with the adjoining surface.
 - 2. Do not begin installation until backup surfaces are in satisfactory condition.

3.3 INSTALLATION - FIBERGLASS REINFORCED PANEL (FRP):

- A. Cut and drill panels with carbide tipped saw blades or drill bits, or cut with snips.
- B. Install panels with manufacturer's recommended gap for panel field and corner joints.
- C. Predrill fastener holes in panels with 1/8" (3.2 mm) oversize.

- D. For trowel type and application of adhesive, follow adhesive manufacturer's recommendations.
- E. Use products acceptable to panel manufacturer and install FRP system in accordance with panel manufacturer's printed instructions.

3.4 CLEANING:

- A. Remove temporary coverings and protection of adjacent work areas. Repair or replace products that have been installed and are damaged. Clean installed products in accordance with manufacturer's instructions prior to Owner's acceptance. Remove construction debris from project site and legally dispose of debris.
 - 1. Remove any adhesive or excessive sealant from panel face using solvent or cleaner recommended by panel manufacturer.

END OF SECTION 09 77 00

SECTION 10 21 13.21 – SOLID COMPOSITE TOILET COMPARTMENTS

PART 1 - GENERAL

1.1 RELATED DOCUMENTS

- A. Drawings and general provisions of the Contract, including General and Supplementary Conditions and Division 01 Specification Sections, apply to this Section.

1.2 SUMMARY

- A. This Section includes solid color reinforced composite units as follows:
 - 1. Toilet Enclosures: Ceiling hung.
 - 2. Urinal Screens: Wall mounted.
- B. Related Sections:
 - 1. Section 05 50 00 "Metal Fabrications" for supports that attach ceiling-hung compartments to overhead structural system.
 - 2. Section 06 10 00 "Rough Carpentry" for blocking in metal stud framed partitions.
 - 3. Section 10 28 00 "Toilet Accessories" for toilet tissue dispensers, grab bars, and similar accessories.

1.3 PERFORMANCE REQUIREMENTS

- A. Graffiti Resistance: Partition material shall have the following graffiti removal characteristics when tested in accordance with ASTM D6578-00 Standard Practice for Determination of Graffiti Resistance in accordance with Section 9, "Graffiti Removal Procedure Using Manual Solvent Rubs":
 - 1. Cleanability: Five (5) required staining agents shall be cleaned off material.
- B. Scratch Resistance: Partition material shall have the following characteristics when tested in accordance with ASTM D2197-98(2002) Standard Test Method for Adhesion of Organic Coating by Scrape Adhesion, using Gardner Stock #PA-2197/ST pointed stylus attachment on scrape tester:
 - 1. Scratch Resistance: Maximum Load Value shall exceed 10 kilograms.
- C. Surface-Burning Characteristics: As determined by testing identical products according to ASTM E 84, or another standard acceptable to authorities having jurisdiction, by a qualified testing agency. Identify products with appropriate markings of applicable testing agency.
 - 1. Flame-Spread Index: 75 or less.
 - 2. Smoke-Developed Index: 450 or less.

1.4 SUBMITTALS

- A. Product Data: For each type of product indicated. Include construction details, material descriptions, dimensions of individual components and profiles, and finishes.
- B. Shop Drawings: Include plans, elevations, sections, details, and attachments to other work.
 - 1. Show locations of cutouts for compartment-mounted toilet and bath accessories.
 - 2. Show locations of reinforcements for compartment-mounted toilet and bath accessories.
- C. Samples for Initial Selection: For each type of unit indicated.
- D. Samples for Verification: Of each type of color and finish required for units, prepared on 6-inch-(150-mm-) square Samples of same thickness and material indicated for Work.

1.5 CLOSEOUT SUBMITTALS

- A. Maintenance Data: For toilet compartments to include in maintenance manuals.

1.6 QUALITY ASSURANCE

- A. Comply with requirements in GSA's CID-A-A-60003, "Partitions, Toilets, Complete."
- B. Regulatory Requirements: Comply with applicable provisions in the U.S. Architectural & Transportation Barriers Compliance Board's "Americans with Disabilities Act (ADA) and Architectural Barriers Act (ABA) Accessibility Guidelines for Buildings and Facilities" for toilet compartments designated as accessible.

1.7 PROJECT CONDITIONS

- A. Field Measurements: Verify actual locations of walls, columns, ceilings, and other construction contiguous with toilet and shower compartments by field measurements before fabrication and indicate measurements on Shop Drawings.
 - 1. Established Dimensions: Where field measurements cannot be made without delaying the Work, establish dimensions and proceed with fabricating toilet and shower compartments without field measurements. Coordinate wall, floor, ceilings, and other contiguous construction to ensure that actual dimensions correspond to established dimensions.

1.8 WARRANTY

- A. Special Warranty: Manufacturer's standard form in which manufacturer agrees to replace toilet compartments that develop defects and that fail in materials or workmanship, including panels, doors, and stiles against breakage, corrosion, delamination, within specified warranty period.
 - 1. Warranty Period: 10 years from date of Substantial Completion.

PART 2 - PRODUCTS

2.1 MATERIALS

- A. Stainless-Steel Sheet: ASTM A 666, Type 304, stretcher-leveled standard of flatness.
- B. Stainless-Steel Castings: ASTM A 743/A 743M.

2.2 SOLID COLOR REINFORCED COMPOSITE UNITS

- A. Basis of Design: Bobrick Washroom Equipment, Inc.; #1098/1098.67 Sierra Series Solid Color Reinforced Composite toilet partitions.
- B. Toilet-Enclosure Style: Ceiling hung.
- C. Urinal-Screen Style: Wall hung.
- D. Door, Panel, Pilaster Construction: Solid color reinforced composite material, which is composed of dyes, organic fibrous material, and polycarbonate/phenolic resins. Material shall have a non-ghosting, graffiti resistant surface integrally bonded to core through a series of manufacturing steps requiring thermal and mechanical pressure; with eased edges, and with homogenous color and pattern throughout thickness of material.
 - 1. Stiles and Doors: 3/4" (19mm).
 - 2. Panels: 1/2" (13mm).
 - 3. Color: Bobrick Sierra Series; SC02 Desert Beige.
- E. Pilaster Sleeves (Caps): Stainless-steel sheet, not less than 0.031-inch nominal thickness and 3 inches high, finished to match hardware.

- F. Brackets and Fittings: **Standard** ~~Vandal-resistant (.67 Series)~~ through-bolted, stainless steel, pin-in-head Torx sex bolt fasteners shall be used for panel-to-stile connections.
1. Mounting brackets: 18-gauge (1.2mm) stainless steel and extend full height of panel.
 - a. U-channels shall be furnished to secure panels to stiles.
 - b. Angle brackets shall be furnished to secure stiles-to-walls and panels-to-walls.
 - c. Fasteners at locations connecting panels-to-stiles shall utilize through-bolted, stainless steel, pin-in-head Torx sex bolt fasteners. Through-bolted fasteners shall withstand direct pull force exceeding 1,500 lbs. per fastener.
 - d. Wall Mounted Urinal Screen Brackets: 11 gauge (3mm) double thickness.

2.3 ACCESSORIES

- A. Hardware and Accessories: **Standard** ~~Vandal-resistant (.67 Series)~~, heavy-duty operating hardware and accessories.
1. Material: Stainless steel, unless noted otherwise.
 2. Hinge: ~~16-gauge (1.6mm) continuous piano-hinge~~ **#18-8 S Type 304 heavy gauge stainless steel with satin finish.**
 3. All doors shall be equipped with ~~self-closing hinge~~ **manufacturer's standard paired, self-closing type that can be adjusted to hold doors open at any angle up to 90-degrees with nylon bearings..**
 4. ~~Continuous piano-hinge shall be attached to door and stile by theft-resistant, pin-in-head Torx stainless steel machine screws into factory installed, threaded brass inserts.~~ **Latch and Keeper: Manufacturer's standard surface-mounted latch unit designed for emergency access.**
 5. Fasteners secured directly into the core are not acceptable.
 6. Door shall be furnished with two 11-gauge (3mm) stainless steel door stop plates with attached rubber bumpers to resist door from being kicked in/out beyond stile.
 7. Door stops and hinges shall be secured with stainless steel, pin-in-head Torx machine screws into threaded brass inserts.
 8. Clothes Hook: Vandal-resistant, stainless steel; through-bolted, theft-resistant, pin-in-head Torx stainless steel screws.
 9. Threaded brass inserts shall withstand a direct pull force exceeding 1,500 lbs per insert. .
- B. Overhead Bracing: Manufacturer's standard continuous, extruded-aluminum head rail with antigrip profile and in manufacturer's standard finish. Head rail brackets shall be 18 gauge stainless steel.
- C. Anchorages and Fasteners: Manufacturer's standard exposed fasteners of Type 304 stainless steel finished to match hardware, with theft-resistant-type heads. Provide sex-type bolts for through-bolt applications. For concealed anchors, use Type 304 stainless steel anchors and fasteners.

2.4 FABRICATION

- A. Ceiling-Hung Units: Provide manufacturer's standard corrosion-resistant anchoring assemblies with leveling adjustment nuts at pilasters for connection to structural support above finished ceiling. Provide assemblies that support pilasters from structure without transmitting load to finished ceiling. Provide sleeves (caps) at tops of pilasters to conceal anchorage.
- B. Door Size and Swings: Unless otherwise indicated, provide 24-inch- wide, in-swinging doors for standard toilet compartments and 36-inch- wide, out-swinging doors with a minimum 32-inch-wide, clear opening for compartments designated as accessible.

PART 3 - EXECUTION

3.1 INSTALLATION

- A. General: Comply with manufacturer's written installation instructions. Install units rigid, straight, level, and plumb. Secure units in position with manufacturer's recommended anchoring devices.
 - 1. Maximum Clearances:
 - a. Pilasters and Panels: 1/2 inch (13 mm).
 - b. Panels and Walls: 1/2 inch (13 mm).
- B. Ceiling-Hung Units: Secure pilasters to supporting structure and level, plumb, and tighten. Hang doors and adjust so bottoms of doors are level with bottoms of pilasters when doors are in closed position.
- C. Urinal Screens: Attach with anchoring devices to suit supporting structure. Set units level and plumb, rigid, and secured to resist lateral impact.

3.2 ADJUSTING

- A. Hardware Adjustment: Adjust and lubricate hardware according to manufacturer's written instructions for proper operation. Set hinges on in-swinging doors to hold doors open approximately 30 degrees from closed position when unlatched. Set hinges on out-swinging doors to return doors to fully closed position.

END OF SECTION 10 21 13.19

OPEN GREENSPACE

TRANSFORMER, REFER TO ELECTRICAL SITE PLAN FOR PAD SIZE AND SPECIFICATIONS

T

PCC SIDEWALK, TYP.

7.84'

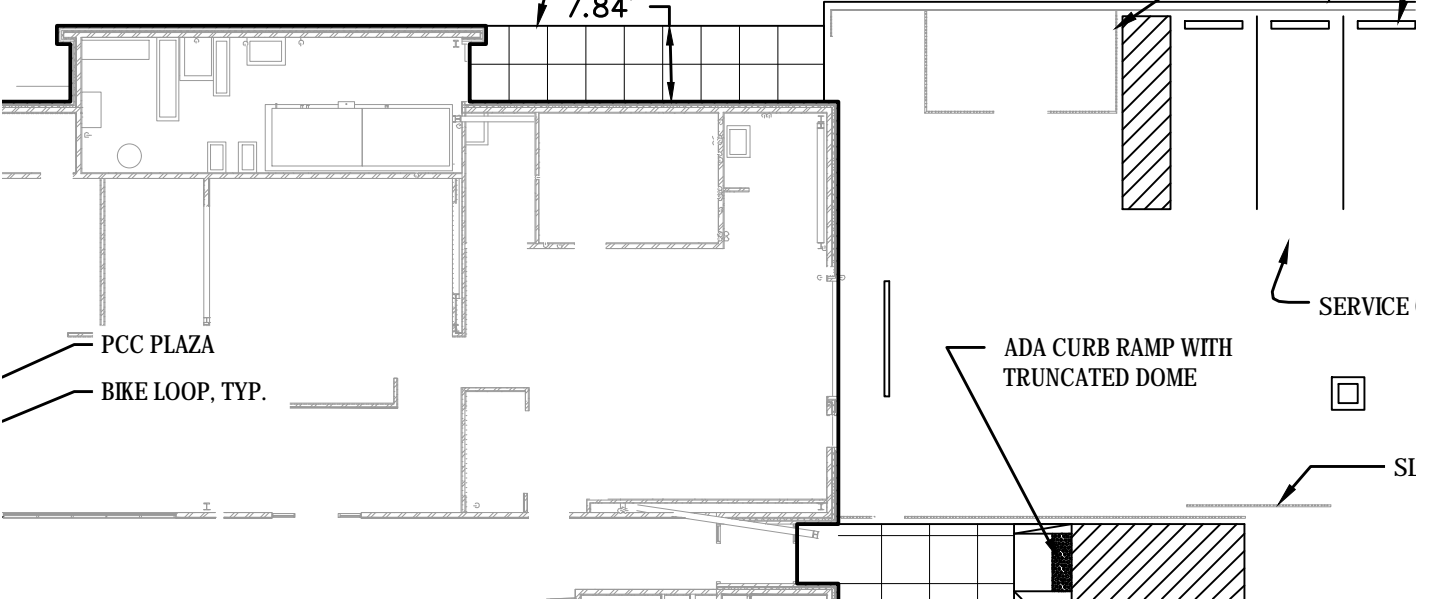

UNIVERSITY OF NEBRASKA-LINCOLN
OUTDOOR ADVENTURES CENTER

14th and W, Lincoln, NE

DATE 11/7/12
MODIFICATION: ADD. A
REF'D SHEET: C1.1
REF'D DETAIL: -

2011.182.00
45.2
SDC 001

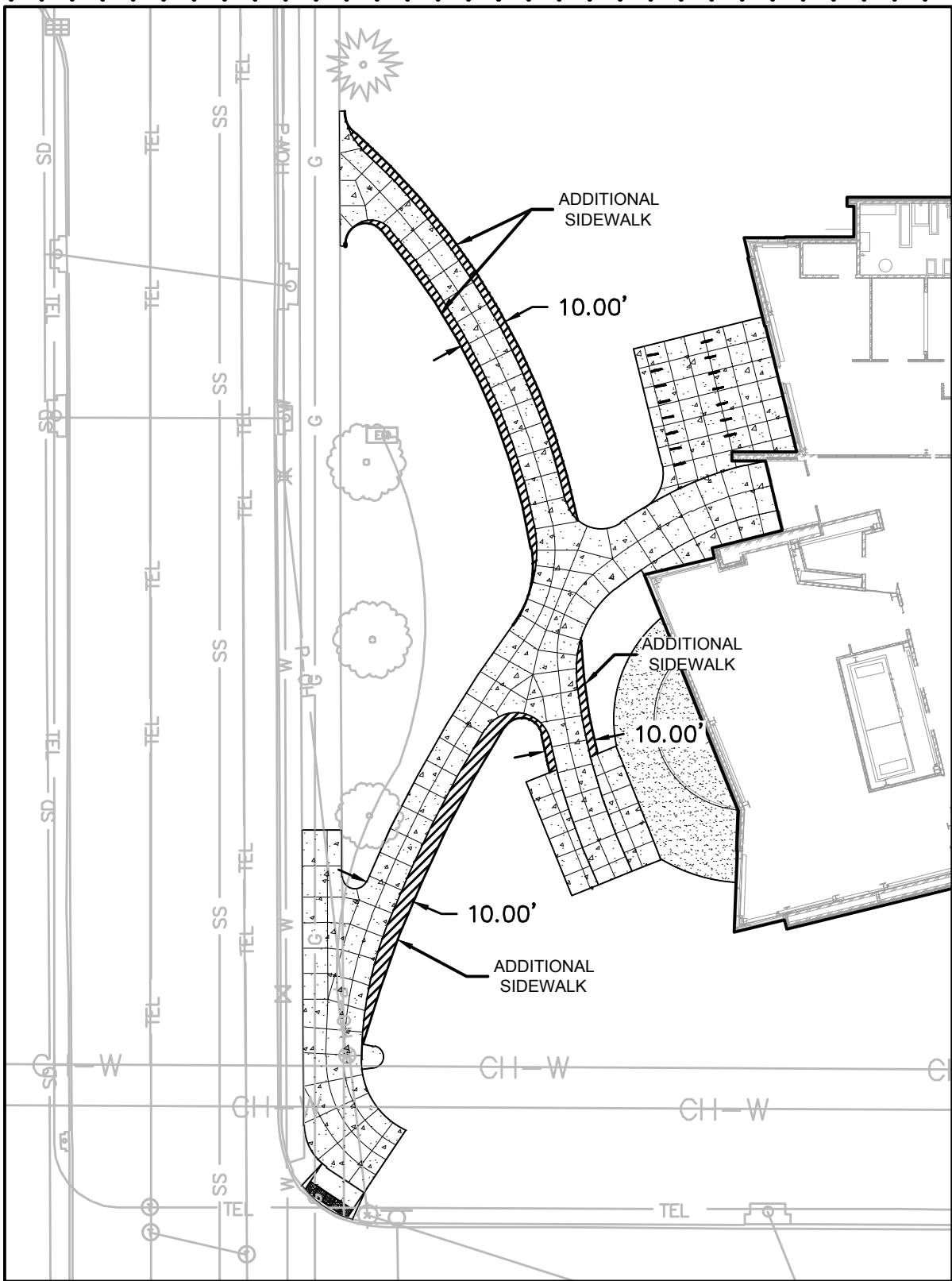

**10' SIDEWALK EXPANSION -
ALTERNATE 3 DETAIL**
SCALE: 1"=30'



UNIVERSITY OF NEBRASKA-LINCOLN
OUTDOOR ADVENTURES CENTER

14th and W, Lincoln, NE

DATE: 11/7/12
MODIFICATION: ADD. A
REF'D SHEET: C4.1
REF'D DETAIL: -

2011.182.00
45.2
SDC 003

DOOR #	# LEAFS	DOOR						FRAME				HARDWARE	FIRE RATING	DETAIL			REMARKS	DOOR #
		WIDTH	HEIGHT	THICKNESS	MATERIAL	FINISH	TYPE	DEPTH	MATERIAL	FINISH	TYPE			HEAD	JAMB	SILL		
100.1	0	3'-0"	7'-0"	1 3/4"	ALUM	FF	ALUM	4 1/2"	ALUM	FF	4	18		3/A9.03	11/A9.01	1/A9.03		100.1
100.2	0	3'-0"	7'-0"	1 3/4"	ALUM	FF	ALUM	4 1/2"	ALUM	FF	4	18		3/A9.03	11/A9.01	1/A9.03		100.2
100A.1	0	3'-0"	7'-0"	1 3/4"	ALUM	FF	ALUM	4 1/2"	ALUM	FF	5	17		19/A10.01	11/A9.01	25/A10.01		100A.1
100A.2	0	3'-0"	7'-0"	1 3/4"	ALUM	FF	ALUM	4 1/2"	ALUM	FF	5	17		19/A10.01	11/A9.01	25/A10.01		100A.2
100C.1	2	6'-0"	7'-0"	1 3/4"	WOOD	FF	F DOUBLE	6"	HM	FF	TYPE B	14		8/A10.01	2/A10.02	--		100C.1
100C.2	1	3'-0"	6'-11"	1 3/4"	ALUM	FF	ALUM	4 1/2"	ALUM	FF	11	8		13/A10.02	15/A10.02	25/A10.02		100C.2
100D.1	1	4'-0"	7'-0"	1 3/4"	ALUM	FF	ALUM	4 1/2"	ALUM	FF	13	6		18/A9.02	15/A10.02	25/A10.02		100D.1
100D.2	1	4'-0"	7'-0"	1 3/4"	ALUM	FF	ALUM	4 1/2"	ALUM	FF	12	9		19/A10.02	15/A10.02	25/A10.02		100D.2
101.1	0	2'-3"	7'-0"	1 3/4"	ALUM	FF	ALUM	4 1/2"	ALUM	FF	14	17		18/A10.02	24/A10.02	30/A10.02		101.1
101.2	0	2'-3"	7'-0"	1 3/4"	ALUM	FF	ALUM	4 1/2"	ALUM	FF	14	17		18/A10.02	24/A10.02	30/A10.02		101.2
101.3	1	3'-0"	7'-0"	1 3/4"	ALUM	FF	ALUM	7 1/4"	ALUM	FF	3	11		16/A10.02	22/A10.02	25/A10.02		101.3
101C.1	1	3'-0"	7'-0"	1 3/4"	WOOD	FF	F	8 1/2"	HM	PT	TYPE A	10		9/A10.01	2/A10.02	--		101C.1
102A.1	1	3'-0"	7'-0"	1 3/4"	WOOD	FF	F	8 1/2"	HM	PT	TYPE A	3A		9/A10.01	2/A10.02	--		102A.1
103.1	1	4'-0"	7'-0"	1 3/4"	WOOD	FF	F	8 1/4"	HM	PT	TYPE A	10		7/A10.01	2/A10.02	--		103.1
103.2	1	3'-0"	7'-0"	1 3/4"	GALV HM	HPC	F	5 3/4"	GALV HM	HPC	TYPE C	11		1/A10.01	13/A10.01	28/A10.01		103.2
103.3	1	12'-0"	12'-0"	2"	ALUM	FF	OHCD	--	STEEL	FF	--	--		14/A10.02	20/A10.02	26/A10.02		103.3
103C.1	1	3'-0"	7'-0"	1 3/4"	WOOD	FF	F	8 1/8"	HM	PT	TYPE A	3A		15/A10.01	2/A10.02	--		103C.1
103D.1	2	6'-0"	7'-0"	1 3/4"	WOOD	FF	F DOUBLE	8"	HM	PT	TYPE B	13		2/A10.01	2/A10.02	--		103D.1
104.1	1	3'-6"	7'-0"	1 3/4"	WOOD	FF	F	8 1/4"	HM	PT	TYPE F	7		7/A10.01	2/A10.02	--		104.1
104.2	1	3'-2"	7'-0"	1 3/4"	WOOD	FF	F DOUBLE	8 1/4"	HM	PT	TYPE H	15		7/A10.01	2/A10.02	--		104.2
105.1	1	3'-6"	7'-0"	1 3/4"	WOOD	FF	F	6"	HM	PT	TYPE J	3B		8/A10.01	2/A10.02	--		105.1
105.2	1	3'-0"	7'-0"	1 3/4"	WOOD	FF	F	5 7/8"	HM	PT	TYPE A	3A		3/A10.01	2/A10.02	--		105.2
105A.1	1	3'-6"	7'-0"	1 3/4"	WOOD	FF	F	5 7/8"	HM	PT	TYPE G	3		3/A10.01	2/A10.02	--		105A.1
106.1	1	4'-0"	7'-0"	1 3/4"	WOOD	FF	F	9 1/8"	HM	PT	TYPE A	17		14/A10.01	20/A10.01	26/A10.01		106.1
106.2	1	3'-0"	7'-0"	1 3/4"	WOOD	FF	F	9 1/8"	HM	PT	TYPE A	17		14/A10.01	20/A10.01	26/A10.01		106.2
107.1	1	3'-6"	7'-0"	1 3/4"	WOOD	FF	F	6"	HM	PT	TYPE K	3B		8/A10.01	2/A10.02	--		107.1
108.1	1	3'-0"	7'-0"	1 3/4"	WOOD	FF	F	5 7/8"	HM	PT	TYPE D	3		3/A10.01	2/A10.02	--		108.1
108.2	1	3'-0"	7'-0"	1 3/4"	WOOD	FF	F	5 7/8"	HM	PT	TYPE D	3		3/A10.01	2/A10.02	--		108.2
108.3	2	6'-0"	7'-0"	1 3/4"	ALUM	FF	ALUM DOUBLE	4 1/2"	ALUM	FF	15	1		21/A10.01	15/A10.02	25/A10.02		108.3
108.4	2	6'-0"	7'-0"	1 3/4"	ALUM	FF	ALUM DOUBLE	4 1/2"	ALUM	FF	15	1		21/A10.01	15/A10.02	25/A10.02		108.4
108A.1	2	4'-8"	7'-0"	1 3/4"	WOOD	FF	F DOUBLE	5 7/8"	HM	PT	TYPE B	12		3/A10.01	2/A10.02	--		108A.1
109.1	1	3'-0"	7'-0"	1 3/4"	WOOD	FF	F	5 7/8"	HM	PT	TYPE A	5		3/A10.01	2/A10.02	--		109.1
109A.1	1	2'-6"	7'-0"	1 3/4"	WOOD	FF	F	5 7/8"	HM	HPC	TYPE A	2A		3/A10.01	2/A10.02	--		109A.1
111.1	1	3'-0"	7'-0"	1 3/4"	WOOD	FF	F	5 7/8"	HM	PT	TYPE A	2		3/A10.01	2/A10.02	--		111.1
113.1	1	3'-0"	7'-0"	1 3/4"	WOOD	FF	F	5 7/8"	HM	PT	TYPE A	4		3/A10.01	2/A10.02	--		113.1
113A.1	1	2'-0"	7'-0"	1 3/4"	HM	HPC	F	5 7/8"	HM	HPC	TYPE A	4		3/A10.01	2/A10.02	--		113A.1
115.1	1	3'-0"	7'-0"	1 3/4"	WOOD	FF	F	5 7/8"	HM	PT	TYPE A	5		3/A10.01	2/A10.02	--		115.1
115A.1	1	2'-6"	7'-0"	1 3/4"	WOOD	FF	F	5 7/8"	HM	HPC	TYPE A	2A		3/A10.01	2/A10.02	--		115A.1
198.1	1	3'-0"	7'-0"	1 1/2"	GALV HM	HPC	FENCE	1 1/2"	GALV HM	HPC	SEE ELEV	16		--	--	--		198.1
198.2	2	6'-0"	7'-0"	1 1/2"	GALV HM	HPC	FENCE DOUBLE	1 1/2"	GALV HM	HPC	SEE ELEV	16A		--	--	--		198.2
199.1	1	4'-0"	7'-0"	1 3/4"	GALV HM	HPC	F	5 3/4"	GALV HM	HPC	TYPE E	11		2/A9.02	3/A9.02	28/A10.01		199.1



UNIVERSITY OF NEBRASKA-LINCOLN
OUTDOOR ADVENTURES CENTER

14th and W, Lincoln, NE

DATE 11/07/12
MODIFICATION: ADDENDUM A
REF'D SHEET: A10.01
REF'D DETAIL: -

2011.182.00
45.02
SDA-001

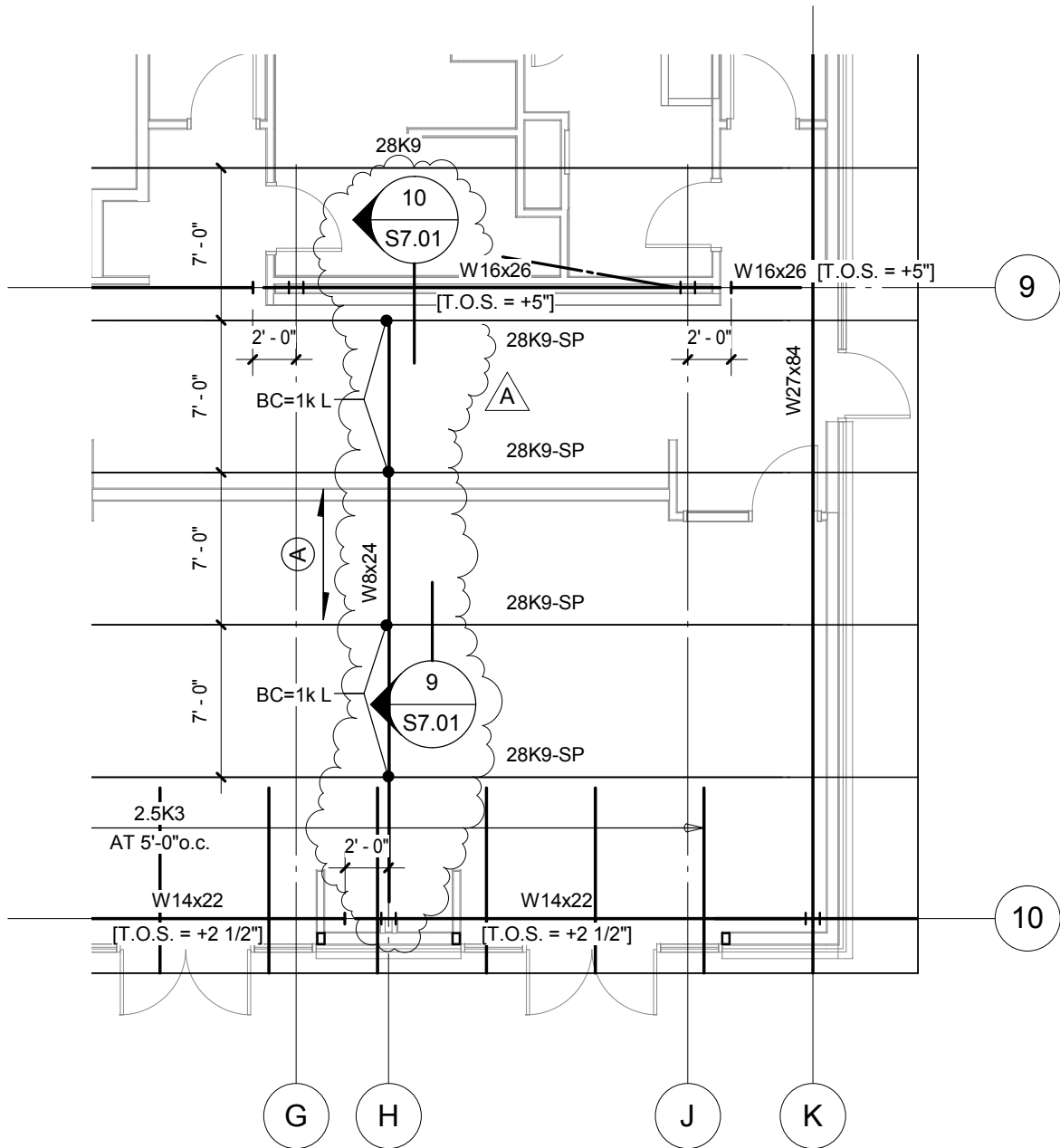

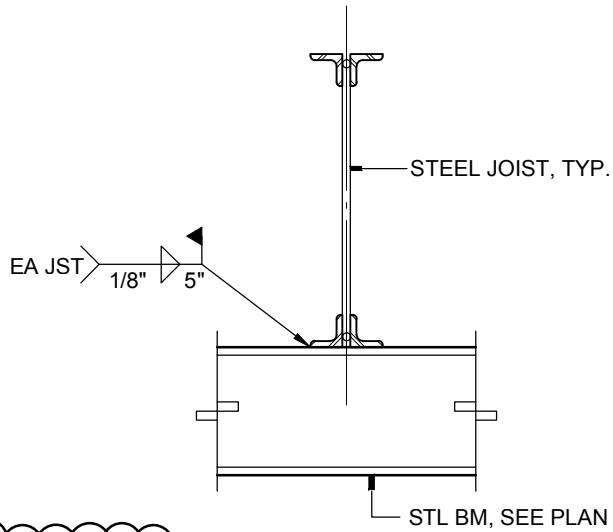

A DETAIL ADDED

9 **OPERABLE WALL BM**
1" = 1'-0"

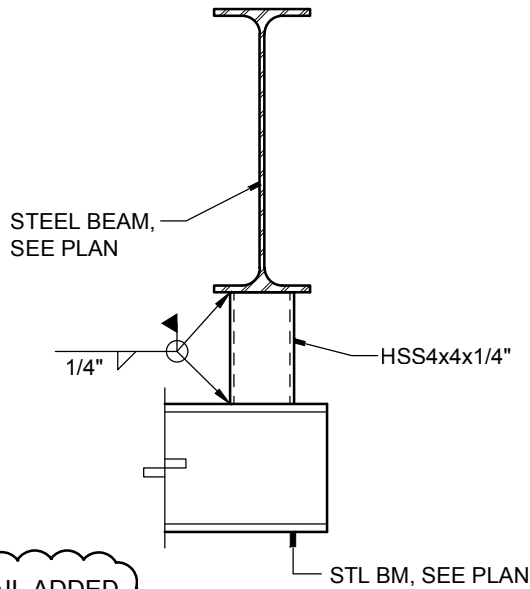

A DETAIL ADDED

10 **OPERABLE WALL BM**
1" = 1'-0"

FLAG NOTES

- 1 INTERLOCK DAMPER TO CLOSE WHEN EXTERIOR DOOR INTO ROOM IS OPEN.
- 2 EXPOSED DUCTWORK IN CLIMBING CENTER, WORKROOM AND MAINTENANCE AREA TO BE DOUBLE WALL ROUND, INSULATED TYPE.

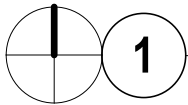
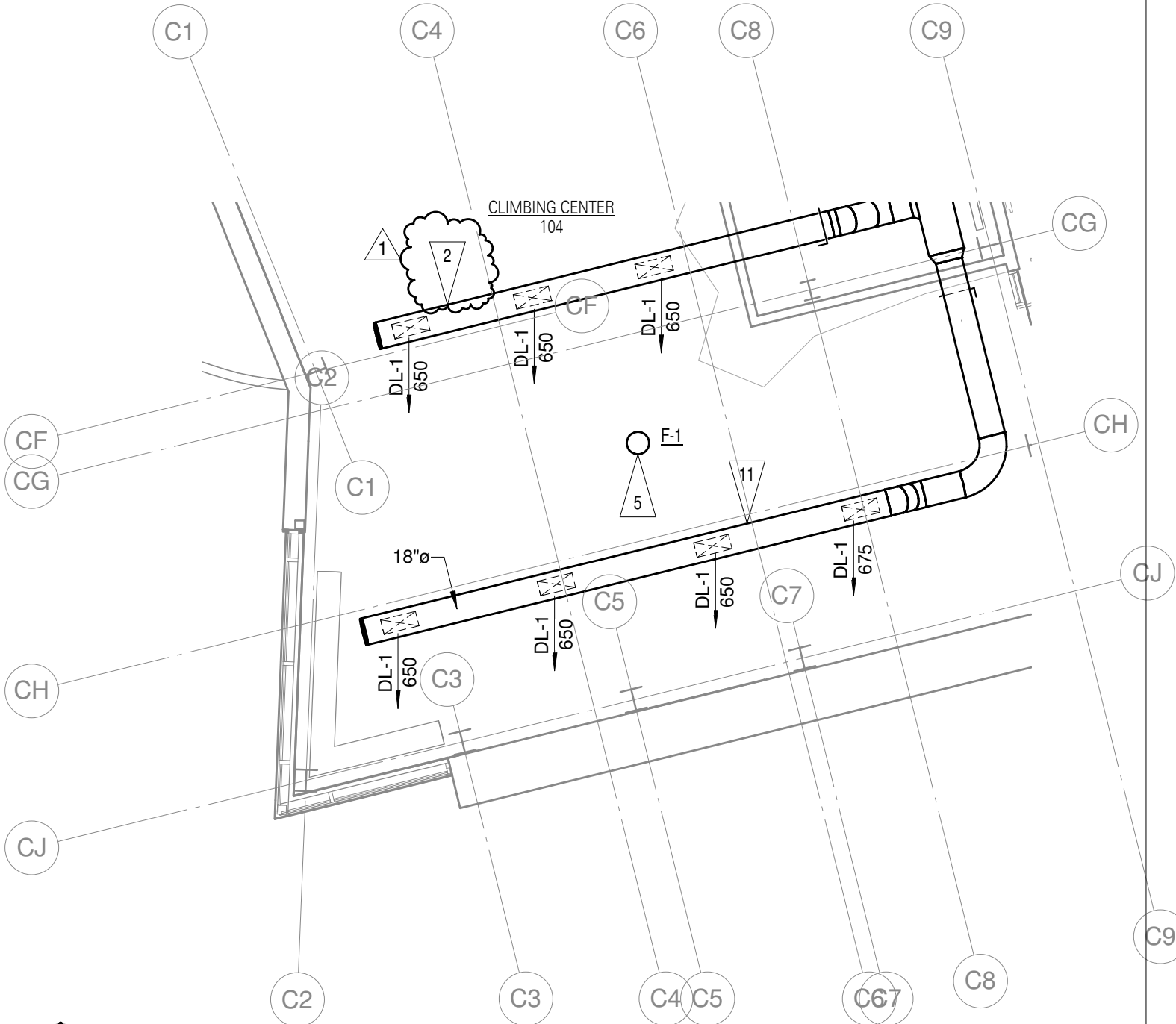

FIRST LEVEL FLOOR PLAN - HVAC

1/8" = 1'-0"

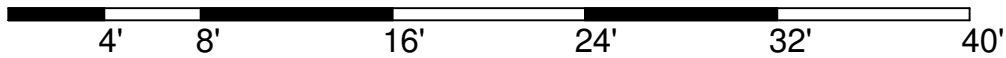

UNIVERSITY OF NEBRASKA-LINCOLN OUTDOOR
ADVENTURES CENTER

14th and W, Lincoln, NE

DATE 11/07/12
MODIFICATION: ADDENDUM A
REF'D SHEET: M1.1
REF'D DETAIL: 1

2011.182.00
45.2
SDM-001

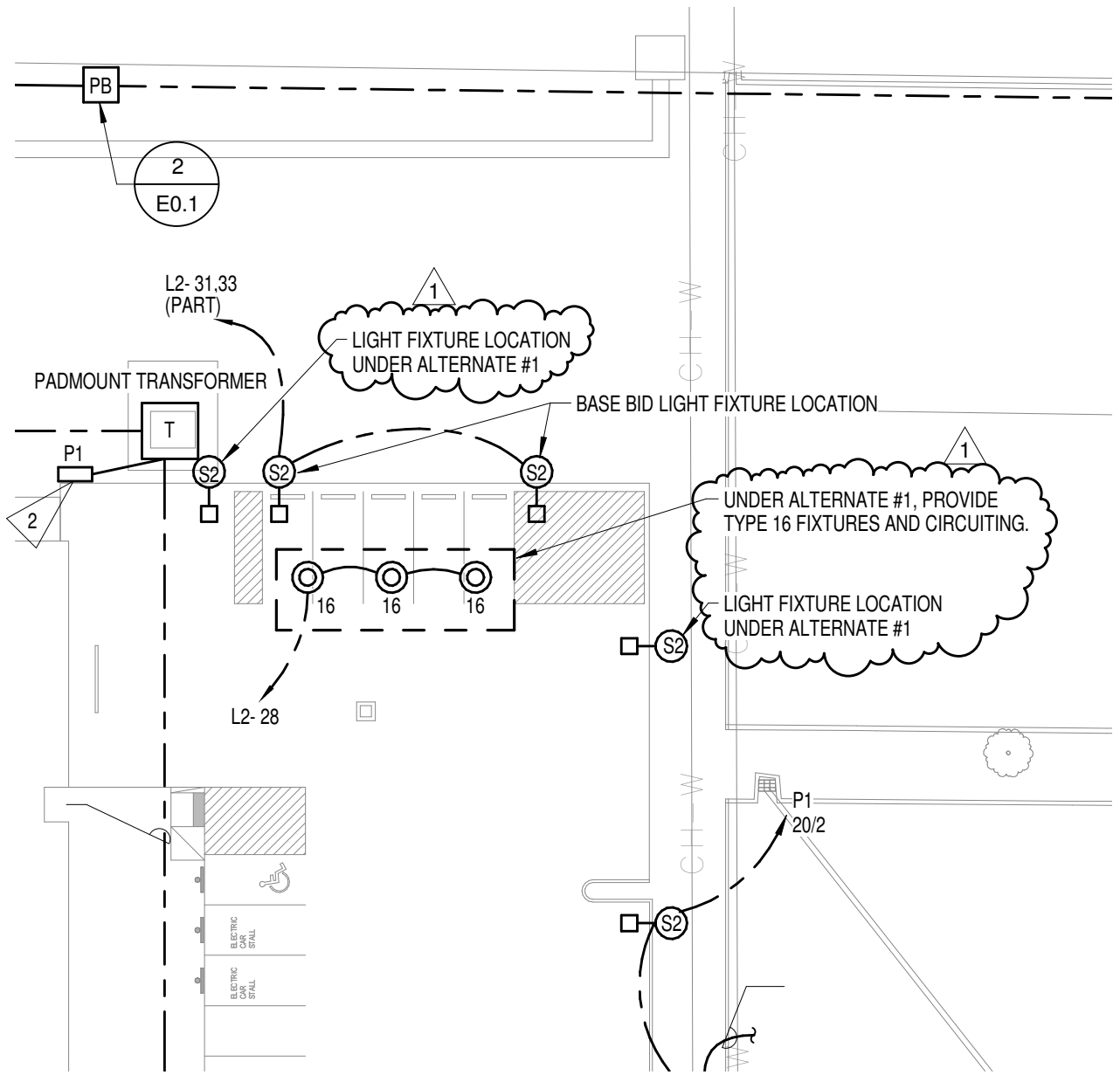

1

SITE PLAN - ELECTRICAL ADDENDUM A

1" = 30'-0"



UNIVERSITY OF NEBRASKA-LINCOLN OUTDOOR
ADVENTURES CENTER

14th and W, Lincoln, NE

DATE 11/02/12
MODIFICATION: ADDENDUM A
REF'D SHEET: E0.1
REF'D DETAIL: -

2011.182.00
45.2
SDE 001

LIGHTING FIXTURE SCHEDULE ADDEDUM A

FIXT NO. (NOTE 12)	MANUFACTURER	CATALOG NO. (NOTE 1)	LAMP DATA		VOLTS	MOUNTING	DESCRIPTION	REMARKS
			QUANTITY AND SIZE	TYPE				
15	LITHONIA	WSTLED-2-SR4-120-PE-ELCW-DDBXD	47W, 82 lm/W	LED	120 V	WALL MOUNT @ 9'-6" AFF	EXTERIOR WALL PACK	NOTE 13
15E	LITHONIA	WSTLED-2-SR4-120-PE-ELCW-DDBXD	47W, 82 lm/W	LED	120 V	WALL MOUNT @ 9'-6" AFF	EXTERIOR WALL PACK	NOTE 13
16	LITHONIA	KACM-1-49B350/50K-SR4-120-DDBXD	58W, 80 lm/W	LED	120 V	SURFACE	SQUARE EXTERIOR AREA LIGHT	
17	FOCAL POINT	FSMAS-FLXP-1T8-1C-120-S-CS96-TS-(NOTE 2)	(1) 32W T8 841	F	120 V	SUSPENDED	LINEAR SLOTLIGHT	NOTE 2,11,13
17E	FOCAL POINT	FSMAS-FLXP-1T8-1C-120-S-CS96-TS-(NOTE 2)	(1) 32W T8 841	F	120 V	SUSPENDED	LINEAR SLOTLIGHT	NOTE 2,11,13
18	HOLOPHANE	IV-654-12-E-W-T-C-IVB1XY	6-54W T5HO 841	F	120 V	48" PENDANT	LINEAR HIGHBAY WITH BAFLE	
18E	HOLOPHANE	IV-654-12-E-W-T-C-IVB1XY	6-54W T5HO 841	F	120 V	48" PENDANT	LINEAR HIGHBAY WITH BAFLE	
19	BARTCO	IST8R-32W-U-IS-F-SM-PT	(1) 32W T8 841	F	120 V	WALL VERTICAL	VANITY LIGHT	
20	GOTHAM	ALED-35/14-6DFR-120	FURNISHED W/ FIXTURE	LED	120 V	RECESSED	4" WET LOCATION DOWNLIGHT	
22	LITHONIA	LV-S-1-R-120/277-UM-CW	FURNISHED W/ FIXTURE	LED	120 V	WALL MOUNT	EXTERIOR EXIT SIGN	NOTE 13

NOTES:

- CONTRACTOR TO VERIFY LIGHT FIXTURE CATALOG NUMBER AND INSTALLATION REQUIREMENTS PRIOR TO ORDERING. FOR EACH FIXTURE UTILIZING DOUBLE ENDED FLUORESCENT LAMPS, PROVIDE INTEGRAL LUMINAIRE DISCONNECT. SEE SPECIFICATIONS.
- REFER TO PLAN DRAWINGS FOR FIXTURE LENGTHS.
- REFER TO PLAN DRAWINGS FOR MOUNTING CONFIGURATION (RECESSED VERSUS SURFACE) AS WELL AS QUANTITY AND DIRECTION OF CHEVRONS.
- FOR SURFACE MOUNT EXIT SIGNS IN EXPOSED CEILING AREAS, PENDANT MOUNT EXIT SIGN WITH 1/2" EMT CONDUIT FROM J-BOX MOUNTED TO STRUCTURE ABOVE.
- ONE (1) LIGHTING SCIENCE 15 WATT PAR 30, 4000K, 943 LUMENS, NARROW FLOOD LAMP. MODEL NO: DFN-30-NW-**-NFL-120.
- PROVIDE T38SL LIVE END FEED CONNECTOR, T23SL STRAIGHT CONNECTOR, T90SL PENDANT STEM, AND T93SL WIREWAY COVER FOR COMPLETE WORKING SYSTEM.
- PROVIDE WITH JUMPER CABLES, LEADER CABLES, JIC BOX CONTROL BOXES WITH CAT 5 CABLES, AND OTHER APPURTENANCES AS NECESSARY FOR A COMPLETE INSTALLATION. PROVIDE 4 HOURS OF FACTORY TRAINING. SUBMIT FACTORY SHOP DRAWING FOR REVIEW PRIOR TO ORDERING.
- BOTTOM OF FIXTURE AT 10'-0" AFF.
- FOR FIXTURE TYPES WITH "E" DESIGNATION, PROVIDE UL924 EMERGENCY BATTERY PACK.

13. LIGHT FIXTURES OF EQUIVALENT QUALITY BY THE FOLLOWING MANUFACTURERS WILL BE CONSIDERED ACCEPTABLE:

FIXTURE NO.	MANUFACTURER	FIXTURE NO.	MANUFACTURER
1	COOPER - METALUX, WILLIAMS	12	COOPER - SURE-LITES, LIGHTALARMS
2/2E	COOPER - METALUX, WILLIAMS	13	COOPER - SURE-LITES, LIGHTALARMS
3/3E	WILLIAMS, COOPER - METALUX	14/14E	COOPER - MCGRAW EDISON, HUBBELL, ELCAST
4/4E	COOPER - PORTFOLIO	15/15E	COOPER - MCGRAW EDISON, HUBBELL, ELCAST
5/5E	WILLIAMS, CORELITE	16	BETALED, COOPER - MCGRAW EDISON
6	COOPER - NEORAY, AXIS	17/17E	AXIS
7/7T	LITON	19	BIRCHWOOD
10/10T	LITON	20	COOPER - PORTFOLIO
		22	COOPER - SURE-LITES, LIGHTALARMS



UNIVERSITY OF NEBRASKA-LINCOLN OUTDOOR ADVENTURES CENTER
 14th and W, Lincoln, NE

DATE: 11/07/12
 APPENDUM A
 MODIFICATION: A
 REFPD SHEET: ES.1
 REFPD DETAIL: -

2011.182.00
 45.2
 SDE-003